

7 0 - 7 4 S A E N E T H O R S E P O W E R



JOHN DEERE

J

DOZER

450J



DOZERS

Specifications

Engine	450J LT	450J LGP
Type	John Deere 4045T with altitude-compensating turbo-charger; meets EPA Tier II non-road emissions regu-lations	John Deere 4045T with altitude-compensating turbo-charger; meets EPA Tier II non-road emissions regu-lations
Rated Power @ 2,200 rpm	70 SAE net hp (52 kW)	74 SAE net hp (55 kW)
Cylinders (wet sleeve)	4	4
Displacement	276 cu. in. (4.52 L)	276 cu. in. (4.52 L)
Bore and Stroke	4.19 x 5.00 in. (106.5 x 127 mm)	4.19 x 5.00 in. (106.5 x 127 mm)
Fuel Consumption, Typical	1.5 to 2.3 gal./hr. (4.9 to 8.7 L/h)	1.5 to 2.3 gal./hr. (4.9 to 8.7 L/h)
Peak Torque	234 lb.-ft. (317 Nm) @ 1,200 rpm	251 lb.-ft. (340 Nm) @ 1,300 rpm
Lubrication	pressure system with full-flow spin-on filter and oil-to-water cooler	
Air Cleaner	dual stage dry type with safety element, precleaner, and dash-mounted restriction indicator	
Electrical System	12 volt with 65-amp alternator	
Cooling Fan	blower	

Transmission	450J LT / 450J LGP
Dual-path, electronic-controlled, hydrostatic drive; load-sensing feature automatically adjusts speed and power to match changing load conditions; each individual track is powered by a variable-displacement piston pump and two-speed motor combination; decelerator controls speed from holding to 5.0 mph (8.0 km/h)	
Travel Speeds (infinitely variable)	
Forward and Reverse	0 to 5.0 mph (0 to 8.0 km/h)

Final Drives
Heavy-duty triple-reduction final drives attach directly to the mainframe and are isolated from track frame and dozer frame loads

Steering
Single-lever steering, direction control, and counterrotation; full power turns and infinitely variable track speeds provide unlimited maneuverability and optimum control; hydrostatic steering eliminates steering clutches and brakes

Brakes
Hydrostatic (dynamic) braking stops the machine whenever the direction-control lever is moved to neutral or whenever the decelerator is depressed to the detent

Automatic Park Brake
Exclusive safety feature engages wet, multiple-disc brakes automatically whenever the engine stops, whenever the operator depresses the decelerator pedal to the brake position, whenever the unit is in neutral for three seconds (with detected motion), or whenever the park lock lever is in the park position; machine cannot be driven with brake applied, reducing wear-out or need for adjustment

Hydraulic System	
System Type	open center
System Pressure Relief	3,000 psi (20 685 kPa)
Pump Type	gear
Pump Flow	15 gpm (56.8 L/min.) @ 2,200 rpm
Oil Return Filter	10 micron
Control	T-bar three function
Cylinders	heat-treated, chrome-plated, polished cylinder rods, hardened steel (replaceable bushings) pivot pins
Reservoir Capacity	8.5 gal. (32.2 L)

Capacities (U.S.)	
Fuel Tank with Lockable Cap	47 gal. (178 L)
Cooling System with Coolant Recovery Tank	17 qt. (16 L)
Engine Oil Including Spin-On Filter	15 qt. (14 L)
Transmission Reservoir Refill with Filter Change	11.3 gal. (42.7 L)
Final Drive (each)	7 qt. (6.6 L)
Hydraulic Reservoir Refill with Filter Change	8.5 gal. (32.2 L)

All power train and hydraulic systems allow for up to 45-degree maximum slope operation.

Undercarriage**450J LT****450J LGP**

John Deere Dura-Trax™ features large deep-heat-treated components; pins and bushings are sealed for life; rollers and idlers are permanently sealed and lubricated; full-length track frame covers reduce material buildup and ease cleaning

Grouser Width (closed center, single bar).....	16 in. (406 mm)	24 in. (610 mm)
Track Shoes (each side)	40	40
Ground Contact Area	2,752 sq. in. (17 775 cm ²)	4,128 sq. in. (26 632 cm ²)
Ground Pressure.....	5.9 psi (40.6 kPa)	4.25 psi (29.3 kPa)
Ground Clearance with Single-Bar Grouser (excluding grouser height).....	13.6 in. (346 mm)	13.6 in. (346 mm)
Length of Track on Ground	86 in. (2184 mm)	86 in. (2184 mm)
Track Gauge (with standard equipment)	57 in. (1450 mm)	65 in. (1650 mm)
Track Rollers (each side)	6	6
Track Pitch	6.29 in. (159.8 mm)	6.29 in. (159.8 mm)

SAE Operating Weights

Base weights were computed for units with standard equipment, rollover protective structures, full fuel tanks, and 175-lb. (79 kg) operators.

97-in. (2464 mm) Blade and 16-in. (406 mm) Track Shoes	16,283 lb. (7401 kg)
124-in. (3150 mm) Blade and 24-in. (610 mm) Track Shoes	17,525 lb. (7966 kg)

Optional or Special Equipment

Add (+) or deduct (-) lb. (kg) as indicated to base weight for units with

Rock Guards (4)	257 lb. (117 kg)	288 lb. (131 kg)
14-in. (343 mm) Track Shoes	- 148 lb. (- 67 kg)	
Swamp Shoes		160 lb. (72 kg)
Deluxe Seat Group	20 lb. (9 kg)	20 lb. (9 kg)
Cab with Heater and Air Conditioner	675 lb. (306 kg)	675 lb. (306 kg)
Under-Seat ROPS Heater	26 lb. (12 kg)	26 lb. (12 kg)
Counterweight, Rear (each)	330 lb. (150 kg)	330 lb. (150 kg)
Counterweight, Front (each).....	240 lb. (109 kg)	240 lb. (109 kg)
Lights, Driving	3 lb. (1 kg)	3 lb. (1 kg)
Work Lights, High Intensity	9 lb. (4 kg)	9 lb. (4 kg)
Front Tow Hook	33 lb. (15 kg)	33 lb. (15 kg)
Retrieval Hitch.....	50 lb. (23 kg)	50 lb. (23 kg)
Extended Drawbar	72 lb. (33 kg)	72 lb. (33 kg)
Limb Risers	229 lb. (104 kg)	229 lb. (104 kg)
Rear Screen	76 lb. (35 kg)	76 lb. (35 kg)
Side Screens	94 lb. (43 kg)	94 lb. (43 kg)
Screens, Front and Doors	179 lb. (81 kg)	179 lb. (81 kg)
4000S Winch.....	1,437 lb. (653 kg)	1,437 lb. (653 kg)
Winch Fairlead, Four Roller.....	187 lb. (85 kg)	187 lb. (85 kg)
Parallelogram Ripper	1,306 lb. (594 kg)	1,306 lb. (594 kg)
90-in. (2286 mm) Blade, All-Hydraulic Heavy-Duty C Frame	38 lb. (17 kg)	
90-in. (2286 mm) Blade, All-Hydraulic Standard C Frame	- 58 lb. (- 26 kg)	
97-in. (2464 mm) Blade, All-Hydraulic Heavy-Duty C Frame	96 lb. (43 kg)	
115-in. (2921 mm) Blade, All-Hydraulic Heavy-Duty C Frame		5 lb. (2 kg)
All-Hydraulic Heavy-Duty C Frame (less blade)	- 1,063 lb. (- 482 kg)	- 1,063 lb. (- 482 kg)

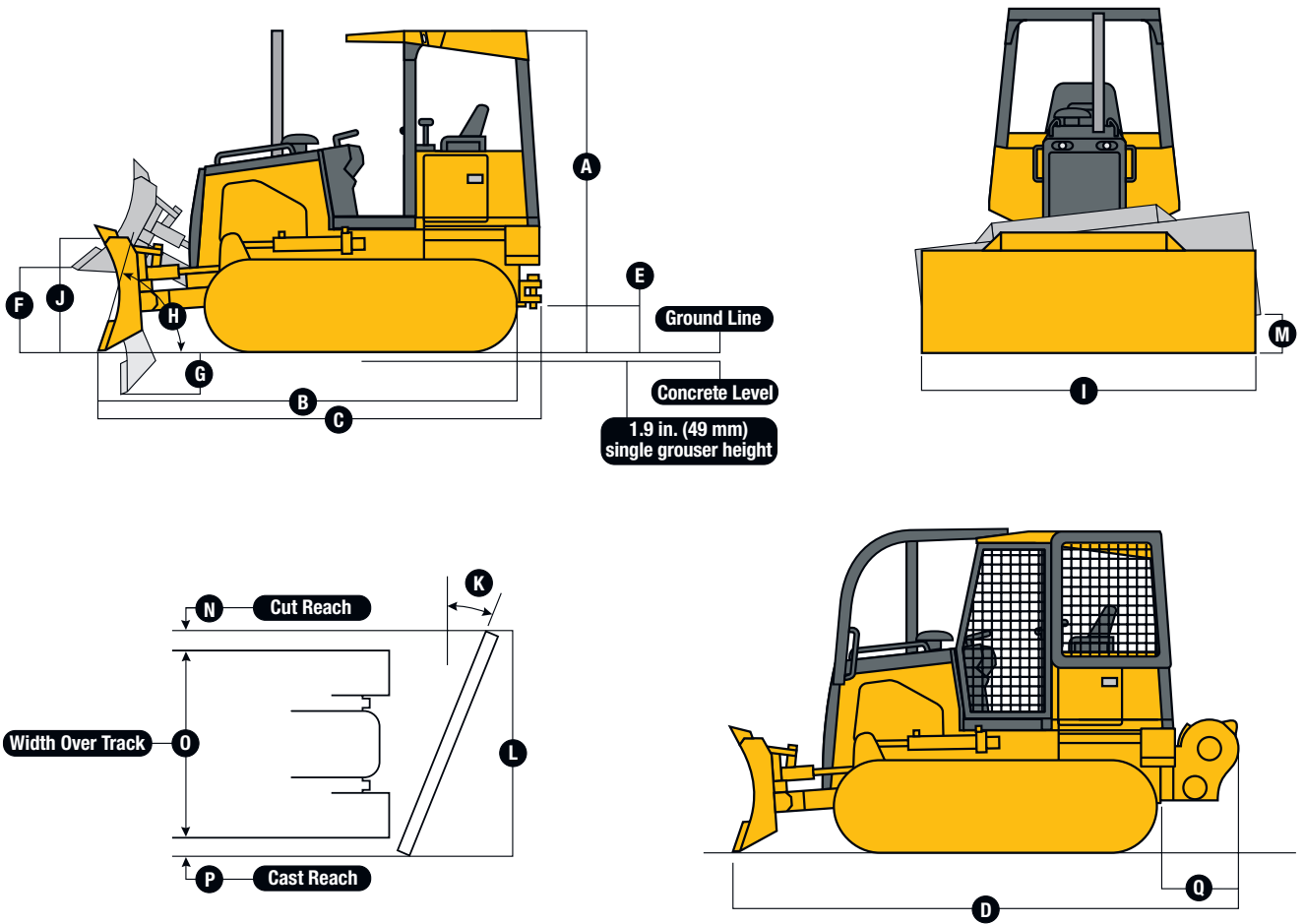

Dimensions

450J LT

450J LGP

A Overall Height with ROPS or Cab	108 in. (2743 mm)	108 in. (2743 mm)
B Overall Length*	155 in. (3937 mm)	158 in. (4013 mm)
C Overall Length with Extended Drawbar	162 in. (4114 mm)	160 in. (4064 mm)
D Overall Length with Winch**	177 in. (4496 mm)	177 in. (4496 mm)
E Ground Clearance, Minimum		
Single-Bar Grouser	13.6 in. (345 mm)	13.6 in. (345 mm)
Swamp Shoes	14.4 in. (366 mm)	14.4 in. (366 mm)
F Blade Lift Height	30.4 in. (773 mm)	30.4 in. (773 mm)
G Blade Digging Depth	20.8 in. (528 mm)	20.8 in. (528 mm)
H Blade Cutting Edge Angle, Adjustable	52 to 60 degrees	52 to 60 degrees
*There is no change to overall length with retrieval hitch.		
**See page 5 for forestry application.		

Blade Specs

I Width	90 in. (2286 mm)
J Height	32.5 in. (826 mm)
SAE Capacity	1.9 cu. yd. (1.4 m ³)
K Blade Angle	25.4 degrees
L Angled Width	82.9 in. (2106 mm)
M Tilt	12.3 in. (313 mm)
N Cut Reach	0 in. (0 mm)
O Width Over Track	73 in. (1854 mm)
P Cast Reach	10 in. (255 mm)

Blade Specs (continued)

450J LT

450J LGP

I Width.....	97 in. (2464 mm)
J Height.....	32.5 in. (826 mm)
SAE Capacity	2.0 cu. yd. (1.5 m ³)
K Blade Angle	25.4 degrees
L Angled Width	89.3 in. (2267 mm)
M Tilt.....	13.3 in. (337 mm)
N Cut Reach.....	3.1 in. (78 mm)
O Width Over Track	73 in. (1854 mm)
P Cast Reach	13.2 in. (335 mm)

97 in. (2464 mm)
32.5 in. (826 mm)
2.0 cu. yd. (1.5 m ³)
22.2 degrees
91.2 in. (2318 mm)
13.3 in. (337 mm)
1.6 in. (41 mm)
79 in. (2006 mm)
10.6 in. (269 mm)

I Width.....	115 in. (2921 mm)
J Height.....	32.5 in. (826 mm)
SAE Capacity	2.29 cu. yd. (1.75 m ³)
K Blade Angle	25.4 degrees
L Angled Width	105.5 in. (2680 mm)
M Tilt.....	15.8 in. (400 mm)
N Cut Reach.....	10.6 in. (268 mm)
O Width Over Track	73 in. (1854 mm)
P Cast Reach	22 in. (558 mm)

115 in. (2921 mm)
32.5 in. (826 mm)
2.29 cu. yd. (1.75 m ³)
25.4 degrees
105.5 in. (2680 mm)
15.8 in. (400 mm)
2.6 in. (65 mm)
89 in. (2260 mm)
14 in. (355 mm)

I Width.....	124 in. (3150 mm)
J Height.....	30.2 in. (767 mm)
SAE Capacity	2.15 cu. yd. (1.64 m ³)
K Blade Angle	25.4 degrees
L Angled Width	113.7 in. (2887 mm)
M Tilt.....	17 in. (432 mm)
N Cut Reach.....	6.8 in. (173 mm)
O Width Over Track	89 in. (2260 mm)
P Cast Reach	17.9 in. (454 mm)

Forestry Application

450J LT / 450J LGP

Available limb risers and screens for the rollover protective structure, John Deere-built, self-contained 4000S Winch* for versatile skidding and clearing operations

D Overall Length with Winch**	177 in. (4496 mm)
Q 4000S Winch Length	29.6 in. (752 mm)

*Reference 4000S Winch spec sheet.
**See page 4 for related dimensions.

Drawbar Pull

Crawler Speed vs Ground Pullusable pull will depend on traction and weight of tractor

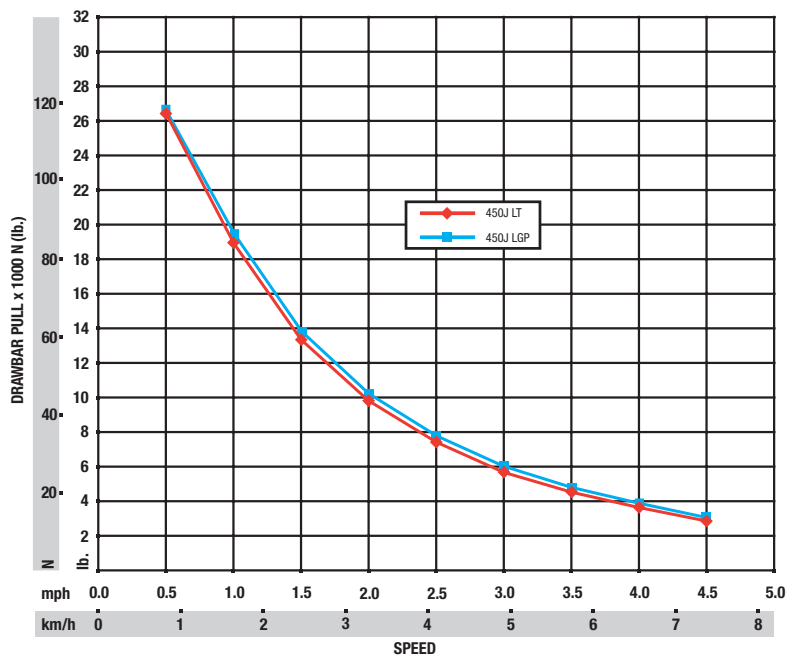

450J CRAWLER DOZER

Key: ● Standard equipment ▲ Optional or special equipment

*See your John Deere dealer for further information.

450J Engine

- Meets EPA Tier II non-road emissions regulations
- Electric fuel shutoff, key start switch
- Oil-to-water engine oil cooler
- Vertical spin-on oil filter
- Vertical spin-on primary fuel filter with water separator
- Vertical spin-on final fuel filter
- Dual-element dry air cleaner, built-in pre-cleaner, and evacuator valve
- Above-hood pre-screener/raincap
- ▲ External primary precleaner*
- Enclosed safety fan guard
- Coolant recovery tank
- Engine coolant to -34°F (-37°C)
- Blower-type cooling fan
- Trash-resistant ten-fin-per-inch in-line radiator
- ▲ Radiator sand screen (steel)
- Under-hood muffler, vertical exhaust stack
- Pre-wired for ether start aid
- ▲ Electric ether start aid
- ▲ Coolant heater, 1,000 watts, 110 volts
- ▲ Coolant heater, fuel fired

Powertrain and Controls

- Dual-path hydrostatic transmission
- Single-lever steering, F-N-R direction control
- Decelerator/brake pedal, automatic retardation
- Engine-speed selection lever
- Ground speed in grip with speed ratio
- Automatic straight-ahead tracking
- Dynamic braking (anti-free wheel)
- Counterrotation
- Transmission neutral lock, safety start switch
- Automatic spring-applied, hydraulic-released parking brake
- Independent transmission oil reservoir with sight gauge
- Onboard diagnostics with visual display
- Oil-to-air transmission oil cooler
- Built-in final drive seal guards
- Triple-reduction final drives with wet multi-disc brakes
- Remote diagnostic test ports
- Maximum forward/reverse speed 5.0 mph (8.0 km/h)
- Selectable reverse speed from set forward speed

C-Frames and Blades

- Six-way all-hydraulic C-frame with adjustable blade pitch
- Remote C-frame pivot grease banks
- Cordura-covered hoses, conveniently replaceable lengths
- Straight end bits
- Adjustable pitch link

Electrical

- 12-volt system
- Fuse panel, blade-style multi-fused circuit breakers
- Electric horn
- Reverse warning alarm
- Master electrical disconnect
- Positive battery terminal covers

450J Electrical (continued)

- By-pass start safety cover at starter
- Electronic monitor, visual and audible warning
- Ground-speed selection display
- Single 12-volt low-maintenance battery, 190-min. reserve capacity, 950 CCA
- ▲ Dual 12-volt low-maintenance batteries, 380 min. reserve capacity, 1,900 CCA
- 65-amp sealed alternator with ROPS
- 20-amp power port, for phone and radio

Hydraulic System

- 15-gpm fixed-displacement gear pump
- ▲ Pump, through-drive for winch or auxiliary pump
- Low-effort T-bar blade control
- Independent reservoir with sight gauge
- Vertical spin-on filter
- O-ring face seal connectors
- Three-function valve
- ▲ Four- and five-function valves with levers, with or without float*
- ▲ Rear auxiliary plumbing

Undercarriage

- Single-flange rollers
- ▲ Double-flange rollers*
- Full-length track frame covers
- Chain guides, front and rear
- Fully protected track-tension adjusters
- Solid sprockets
- Sprocket rock guards (bolt-on)
- ▲ Bolt-on full-length track-roller rock guards
- ▲ Sealed track chains
- ▲ Sealed and lubricated track chains
- ▲ Self-cleaning pyramid swamp shoes*

Lights

- Grille-mounted driving lights (2), rear light (1), halogen, 2,000 candlepower each
- ▲ High-intensity work lights, front (2) and rear (2), with steel guards, 65 watts each

Operator's Station

- Modular ROPS/FOPS canopy, isolation mounted (conforms to SAE J1040)
- ▲ Under-seat ROPS heater, 30,000 Btu/hr
- ▲ Modular ROPS/FOPS cab, isolation mounted (conforms to SAE J1040): Air conditioner, 24,000 Btu/hr / Fresh air intake cab heater/defroster/pressurizer, 18,000 Btu/hr with air precleaner / Dome light / Deluxe headliner with molded air ducts for heater, defroster, and air conditioner / 30,000 Btu/hr under-seat heater / Front windshield and doors, wipers and washers / Tinted safety glass / Antenna for radio / 95-amp alternator
- Right and left access
- Slip-resistant front-mounting steps
- Ergonomically located handholds
- Headliner
- Floormat
- Adjustable footrests
- Adjustable full-length armrests
- Built-in Operator's Manual storage
- Suspension vinyl seat (conforms to SAE J899): Fore and aft/weight and height combined adjustment / Adjustable leg support / Seat

450J Operator's Station (continued)

- belt, 2 in. (51 mm), retractable with CRS (conforms to SAE J386)
- ▲ Deluxe suspension vinyl or cloth seat (conforms to SAE J899): Fore and aft/weight and height combined adjustment / Adjustable leg support / Adjustable backrest angle / Adjustable lumbar support / Adjustable seatback extension / Seat belt, 3 in. (76 mm), retractable with CRS (conforms to SAE J386)
- ▲ Seat belt, 3 in. (76 mm), retractable with CRS (conforms to SAE J386)
- Convex interior rearview mirror
- ▲ Accessories: Convex wide-angle interior rearview mirror / Knee cushions (2) / Seat-side lockable storage box/lunch box/cup holder
- ▲ Rear window wiper and washer for cab
- ▲ AM/FM weatherband radio
- ▲ Complete enclosure ROPS-to-cab conversion panels
- ▲ Rear-and-side-only enclosures
- ▲ Front windshield and doors enclosure

Overall Vehicle

- One-piece unitized construction mainframe
- Front tow loop (bolt-on)
- Reinforced engine and mid-frame bottom guards
- Integral transmission guard
- Heavy-duty louvered grille
- Perforated engine side shields
- Vandal protection lock provisions for: Engine service access cover / Fuel fill / Hydraulic reservoir fill/check / Transmission reservoir fill/check / Instrument panel
- Lockable grease gun/tool storage compartment in right access door
- ▲ Environmental drains
- ▲ Chrome exhaust stack
- ▲ Trademarks/decals, French or Spanish
- ▲ Transport lift and tie-down rings*

Protection Packages

- ▲ Extreme-duty louvered grille and hose protection
- ▲ Limb risers, arched or point-to-point
- ▲ Operator-protective rear screen
- ▲ Operator-protective side screens (ROPS)
- ▲ Operator-protective full-screen package
- ▲ Heavy-duty engine air-intake guard
- ▲ Air-conditioning module guard

Attachments

- ▲ Counterweight, rear, 330 lb. (150 kg) each
- ▲ Counterweight, front, 240 lb. (109 kg) each
- ▲ Retrieval hitch with pin
- ▲ Extended rigid drawbar with pin for pull-type implements
- ▲ Extended drawbar for winch
- ▲ Parallelogram ripper with five shank pockets and three teeth
- ▲ Standard or low-speed winch
- ▲ Power-in/out standard-speed winch
- ▲ Power-in/out low-speed winch
- ▲ Four-roller fairlead for winch
- ▲ Log arch for winch



JOHN DEERE

DKA450J Litho in U.S.A. (04-06)

Net engine power is with standard equipment including air cleaner, exhaust system, alternator, and cooling fan, at standard conditions per SAE J1349 and DIN 6270B, using No. 2-D fuel at 35 API gravity. Gross power is without cooling fan.

Specifications and design subject to change without notice. Wherever applicable, specifications are in accordance with SAE standards. Except where otherwise noted, these specifications are based on a unit with standard equipment, rollover protective structure, full fuel tank, and 175-lb. (79 kg) operator.

