

1 4 5 - 2 0 0 S A E N E T H O R S E P O W E R



JOHN DEERE

J

DOZERS

750J | 850J



750J

145 SAE net hp LT and WT

155 SAE net hp LGP

32,585 lb.

34,395 lb. LT

36,425 lb. WT

36,725 lb. LGP

22-, 24-, 28-, and 34-in. grousers

128-, 130-, 148-, and 156-in. blades



Simply advanced.

Built with the same kind of forward thinking as their highly popular J-Series siblings, the rethought 750J and 850J Dozers redefine the way earthwork gets done. Their unique state-of-the-art Total Machine Control (TMC) enables an

operator to customize machine operation and response to personal preferences. Coupled with an uncommonly smooth full-featured hydrostatic drivetrain, the John Deere J-Series Dozers deliver unsurpassed power, control, and results. Again.

850J

185 SAE net hp LT, WT, and WLT

200 SAE net hp LGP

39,865 lb.

42,715 lb. LT

40,985 lb. WT

43,925 lb. WLT

45,075 lb. LGP

22-, 24-, 30-, and 36-in. grousers

128-, 140-, 146-, 152-, 154-,

158-, and 168-in. blades



Power turns, power management, infinite speed control — John Deere introduced them all 30 years ago. And the redesigned 750J and 850J are loaded with even more productivity- and uptime-boosting enhancements.

Twelve track frames, five mainframes, and a variety of blades let you choose the right crawler configuration for your kind of work.

Purpose-built mainframes for power-angle-tilt and outside-mount blades allow optimized component placement for uncompromised grading ability.

Deere's unique Total Machine Control lets an operator customize the crawler's operational characteristics and response, and even records machine usage.

Cool-on-demand system's hydraulic-driven fan runs only as needed for increased power and fuel efficiency, less noise, and reduced cooler and radiator core wear.

Best-in-class service access, same-side daily servicing, and extended engine, hydraulic, and transmission oil and filter service intervals help keep downtime to a minimum.



Counterrotation is a productivity-boosting feature that enables an operator to overcome heavy corner loads and quickly reposition the blade on the go. Provides space-saving spot turns, too.



Independent track control lets an operator speed up or slow down each side, for smooth, full-power turns. An automatic 10-percent horsepower boost helps carry more material in a turn.



No need to cross-steer or ride a brake with these dozers. The 750J and 850J steer the same and maintain their preset speed whether working on level terrain or a 2-to-1 slope.

Maximize productivity with minimal effort.

All dozers move the earth. But if you want one that does more with a lot less effort, you'll choose a John Deere J-Series. State-of-the-art electronic controls put you in complete command of a whole arsenal of hydrostatic advantages, including power turns, counterrotation, and

infinitely variable travel speeds. What's more, Total Machine Control lets an operator customize decelerator mode and response, forward/reverse ground speed ranges, steering modulation, and forward/reverse speed ratios. Nothing else even comes close.

Low-effort controls command the blade and a full-featured hydrostatic drivetrain, ensuring predictable response at all times in all conditions.

Simply set the maximum desired ground speed and the power-management system automatically maintains peak engine rpm and power efficiency without stalling or shifting.

Infinitely variable range to 6.8 mph gives total flexibility to match ground speed to the load. Travel can also be varied to fit specific applications, terrain, or operating preferences — and even limited to maximize undercarriage life.

Center of gravity is optimized, giving these dozers the balance and stability needed for superior grade work.

Fully modulated drivetrain ensures smooth starts and direction changes, while virtually eliminating jerky or abrupt movements.



The image shows the interior of a skid steer loader operator's cab. A grey upholstered seat is the central focus, with a red ball on a black lever in front of it. To the left is a control panel with a joystick and various buttons. To the right is a steering wheel. The cab has a black frame and a window. The background is a plain, light-colored wall.

Get more done within our comfort zone.

Generous hydraulic flow and precise metering ensure powerful and quick blade response, while providing a natural "feel" that will enhance any operator's grading skills. A thumb-actuated switch provides low-effort angle control.

Retractable seat belt, slip-resistant floor mat, convenient grab bars, neutral-start lever, and automatic park brake help keep the operator out of harm's way.

Deluxe suspension armchair won't cramp your operator's style. Seven-way adjustable seat provides plenty of legroom and daylong comfort. Arm and footrests also adjust.

Ergonomically correct joystick provides intuitive, low-effort control of steering, forward/reverse travel, and ground speed. It's detented so it doesn't require an operator's constant touch or attention, and employs a thumb-actuated travel-speed switch.

Convenient 12-volt port provides power for accessories such as cell phones.

Want your operators to be more productive? Put them in the seat of this spacious air-conditioned modular cab. From their ergonomically designed fully customizable controls to best-in-class visibility, J-Series Dozers are loaded with everything you need to keep your operators cool, calm, productive – and on your payroll.



Cab-forward design positions the operator for a more stable ride and a commanding view behind, below, and beyond the blade. Side and rear visibility is equally unobstructed. Monitor keeps a vigilant watch on vital machine functions with warnings you can see and hear.



Exclusive TMC lets you customize decelerator mode and response, forward/reverse ground speed ranges, steering modulation, FNR shift rate, and forward/reverse speed ratios, for unsurpassed one-of-a-kind control.



Choose the decelerator function that's right for the job. Slow both ground speed and engine rpm, or ground speed only to help maintain traction without affecting engine power and hydraulic response. Fully depressing the pedal applies the brakes.



Automotive-style directional vents deliver effective airflow to keep the glass clear and the cab comfortable. Air conditioning is standard on all cabs. For ROPS-only crawlers, an optional under-seat heater helps warm the operator.



High-intensity halogen driving lights are standard. Or opt for the factory-installed 360-degree light package and extend your workday beyond normal daylight hours.

One-piece welded main-frame resists torsional stress, absorbs shock loads, and delivers maximum strength while allowing easy service access to major components.

Individually replaceable wet-sleeve cylinder liners provide uniform engine cooling and long-term durability.

Sealed transmission electrical connectors with gold-pin connectors prevent moisture and contaminants from entering terminals and resist corrosion for increased reliability.



Nothing lasts like a Deere, either.

Designed and built with state-of-the-art tools and techniques by a quality-conscious workforce at our world-class facility in Dubuque, Iowa, the J-Series are loaded with uptime-boosting features. Enhancements include a variable-speed hydraulic-driven cooling system fan, gold-plated electrical connectors, and

extended service intervals. These, plus traditional Deere durability features such as one-piece unitized mainframes, Dura-Trax™ undercarriage, wet-sleeve engine liners, O-ring face-seal hose couplers, and isolated planetary final drives keep them keeping on. When you know how they're built, you'll run a Deere.

No need for elevated sprockets. Heavy-duty double-reduction planetary final drives are mounted independent of the track frames, where they're effectively protected from shock loads.

One-piece rigid track frames ensure long-term track alignment. Smooth idler-to-sprocket covers shed material build-up for easy clean-out.

Bolt-on wear parts for the chain guides and push-beam mounts virtually eliminate difficult and time-consuming cut-and-weld repairs.



The PAT dozer's closed-cell blade design and box-section C-frame deliver exceptional strength and durability. Outside-mounted dozer push beams are equally durable.



Bypass start protection, automatic park brake, convenient handholds, and slip-resistant steps help keep the operator out of harm's way.

Dura-Trax™ heavy-duty sealed and lubricated undercarriage is loaded with features that give it uncommon value. Unlike elevated tracks, its traditional oval design has only two wear-causing stress points, for longer life.

Blade hoses are steel-cable supported and Cordura covered for extra protection.



Hood and side shield perforations act as a “first filter,” preventing entry of most debris. Anything that gets past the 5-mm holes also easily passes through the cooler cores.



Unitized mainframe with flush-fit bottom guards combines with tight-fitting side shields to prevent debris from being drawn into the engine compartment.



No stacked coolers in these crawlers. Side-by-side cores with wide fin spacing reduce clogging and are easy to clean.

Keep your cool and burn less fuel.

J-Series Dozers are designed to run cool regardless of what’s in the air or underfoot. Their highly effective cooling system employs a hydraulic-driven variable-speed suction fan that operates only as needed for maximum power and efficiency.

For work in environments with lots of airborne debris, an optional reversing fan automatically back-blows to help shed debris from cooler cores and side screens. So your 750J or 850J can work long and hard without breaking a sweat.

Variable-speed fan automatically speeds up or slows down, operating only as needed to keep things cool. Helps conserve power and fuel, while reducing noise.

Air isn't blown into the coolers, so engine and transmission reach operating temperatures more quickly in cold weather. Warm fluids flow easier, helping extend component life, too.

Optional programmable fan automatically reverses to help eliminate cooler-clogging buildup. Or press a button on the dash to actuate cleaning cycles as needed.

With the fan positioned just behind the grille, coolers are less vulnerable to damage. Hinged grille opens wide for convenient clean out.

Suction fan is more efficient than blower designs, eliminating the need for oversize coolers. There's no need for a radiator screen to decrease tube erosion, either.





The J-Series' highly adaptable drivetrain makes them ideal for work with rear-mount attachments such as rippers and cable plows.



Forestry protection packages and waste handler configurations help these machines survive and thrive in tough applications.

Built to do one job extremely well – yours.

Yours isn't just any business. Why settle for just any crawler? Choose a J-Series Dozer in standard, long-track, wide-track, wide-long track, and low ground-pressure configurations with inside-mounted PAT or outside-mounted straight or semi-U blades. What's

more, these highly productive and uniquely versatile machines can be equipped with a variety of special-duty and severe-application packages to help them thrive in a wide variety of work. And tackle tasks that other crawlers can't. Ask your dealer for details.

Purpose-built mainframes for both power-angle-tilt and outside-mounted dozers allow optimized component placement for uncompromised grading ability.

Optional reversing fan automatically back-blows every 30 minutes to help keep radiator cores clean, for extra uptime in environments with heavy airborne debris.

BLADE CONFIGURATIONS

	750J	750J LT	750J WT	750J LGP
PAT	•	•		•
Semi-U	•		•	
Straight	•		•	

	850J	850J LT	850J WT	850J WLT	850J LGP
PAT		•		•	•
Semi-U	•		•		•
Straight					•



Uncover new ways to keep costs down.



Vertical filters allow quick, no-spill changes. Engine, hydraulics, and transmission utilize a common oil, further simplifying service.



Advanced in-cab monitor gives easy-to-understand messages for quick and easy troubleshooting without special tools.



Operator station tilts a full 70 degrees in only minutes, for wide-open access to internal components. Unlike other crawlers, there's no need to disconnect linkages, hydraulics, or wiring.

Swing open their hinged doors and you'll uncover lots of the ways these crawlers help keep maintenance to a minimum. Same-side daily service points make quick work of the daily routine, and extended engine oil and

drivetrain service intervals let you work longer between changes. Other timesaving features include an easy-to-clean undercarriage, quick-to-replace hydraulic hoses, and designed-in diagnostics, to list just a few.

Separate hydraulic and hydrostatic reservoirs eliminate any possibility of cross-contamination. Sight gauges give fluid levels at a glance.

Hinged side shields open wide for ground-level access to dipsticks, fill tubes, batteries, master electrical shutoff, and engine, transmission, and hydraulic filters.



Fluid sample ports and remote drive system test ports simplify preventative maintenance work and troubleshooting for increased uptime.

Remote lube banks provide easy access to difficult-to-reach crossbar and C-frame pivots. Convenient lube chart ensures that nothing gets overlooked.

Five-hundred-hour engine oil and 2,000-hour transmission and hydraulic fluid intervals decrease downtime and expense.



Specifications

Engine	750J	750J LT	750J WT	750J LGP
Type	John Deere PowerTech™ 6068H with turbocharger and air-to-air after-cooler; certified to EPA Tier 2 emissions	John Deere PowerTech 6068H with turbocharger and air-to-air after-cooler; certified to EPA Tier 2 emissions	John Deere PowerTech 6068H with turbocharger and air-to-air after-cooler; certified to EPA Tier 2 emissions	John Deere PowerTech 6068H with turbocharger and air-to-air after-cooler; certified to EPA Tier 2 emissions
Rated Power @ 2,100 rpm	145 SAE net hp (108 kW) / 157 SAE gross hp (117 kW)	145 SAE net hp (108 kW) / 157 SAE gross hp (117 kW)	145 SAE net hp (108 kW) / 157 SAE gross hp (117 kW)	155 SAE net hp (116 kW) / 168 SAE gross hp (125 kW)
Cylinders	6	6	6	6
Displacement	414 cu. in. (6.8 L)	414 cu. in. (6.8 L)	414 cu. in. (6.8 L)	414 cu. in. (6.8 L)
Maximum Net Torque @ 1,400 rpm	500 lb.-ft. (680 Nm)	500 lb.-ft. (680 Nm)	500 lb.-ft. (680 Nm)	540 lb.-ft. (730 Nm)
Lubrication	pressure system with full-flow spin-on filter and oil-to-water cooler	pressure system with full-flow spin-on filter and oil-to-water cooler	pressure system with full-flow spin-on filter and oil-to-water cooler	pressure system with full-flow spin-on filter and oil-to-water cooler
Air Cleaner	dual-stage dry type with safety element, precleaner, and underhood restriction indicator	dual-stage dry type with safety element, precleaner, and underhood restriction indicator	dual-stage dry type with safety element, precleaner, and underhood restriction indicator	dual-stage dry type with safety element, precleaner, and underhood restriction indicator
Electrical System	24 volt with 80-amp alternator (cab), 55-amp alternator (canopy)	24 volt with 80-amp alternator (cab), 55-amp alternator (canopy)	24 volt with 80-amp alternator (cab), 55-amp alternator (canopy)	24 volt with 80-amp alternator (cab), 55-amp alternator (canopy)
Batteries (two 12-volt)	950 cold-cranking amps, 190-min. reserve capacity	950 cold-cranking amps, 190-min. reserve capacity	950 cold-cranking amps, 190-min. reserve capacity	950 cold-cranking amps, 190-min. reserve capacity
Cooling Fan	variable-speed suction	variable-speed suction	variable-speed suction	variable-speed suction
Cooling Fan Filter, Return Oil	10 micron	10 micron	10 micron	10 micron

Transmission

Automatic, dual-path, hydrostatic drive; load-sensing feature automatically adjusts speed and power to match changing load conditions; each individually controlled track is powered by a variable-displacement piston pump and motor combination; travel speeds (forward and reverse) infinite to 6.3 mph (0 to 10 km/h); ground-speed selection buttons on single-lever steering and direction control; independently selectable reverse speed ratios 80%, 100%, 115%, or 130% of forward ground speed; decelerator pedal controls ground speed to dead stop

Type	dual-path hydrostatic
System Relief Pressure	6,650 psi (45 850 kPa)
Filter, Charge Oil	10 micron
Cooling	oil-to-air
Travel Speeds (forward and reverse)	0–6.3 mph (0–10 km/h) / 6.8 mph (11 km/h) max. (optional)

Final Drives

Double-reduction, planetary final drives transfer torque loads over three gear sets; mounted independently of track frames and dozer push frames for isolation from shock loads				
Total Ratio	46.4056 to 1	46.4056 to 1	46.4056 to 1	46.4056 to 1
Drawbar Pull				
Maximum	55,000 lb. (245 kN)	55,000 lb. (245 kN)	55,000 lb. (245 kN)	55,000 lb. (245 kN)
@ 1.2 mph (1.9 km/h)	33,000 lb. (147 kN)	33,000 lb. (147 kN)	33,000 lb. (147 kN)	35,500 lb. (156 kN)
@ 2.0 mph (3.2 km/h)	22,000 lb. (98 kN)	22,000 lb. (98 kN)	22,000 lb. (98 kN)	24,000 lb. (107 kN)

Steering

Single-lever steering, speed, direction control, and counterrotation; full power turns and infinitely variable track speeds provide unlimited maneuverability and optimum control; hydrostatic steering eliminates steering clutches and brakes

Brakes

Hydrostatic (dynamic) braking stops machine when the direction/steering control lever is moved to neutral or the decelerator is depressed to the end of travel

Type	hydraulic
------	-----------

Automatic Parking Brake

Exclusive safety feature engages wet, multiple-disc brakes whenever the engine stops, whenever the decelerator is depressed to the end of travel, or whenever the park lock lever is placed in the start or neutral positions and motion is detected; machine cannot be driven with brake applied, reducing wear out or need for adjustment

Type	spring-applied, hydraulic release
------	-----------------------------------

Hydraulic System

System Type	load sense	load sense	load sense	load sense
System Relief Pressure	3,625 psi (25 000 kPa)	3,625 psi (25 000 kPa)	3,625 psi (25 000 kPa)	3,625 psi (25 000 kPa)
Differential Pressure	275 psi (1900 kPa)	275 psi (1900 kPa)	275 psi (1900 kPa)	275 psi (1900 kPa)
Pump Type	piston	piston	piston	piston
Pump (63 cc)	38 gpm (144 L/min.)	38 gpm (144 L/min.)	38 gpm (144 L/min.)	38 gpm (144 L/min.)
Maximum Flow @ Unloaded High Idle	37 gpm (140 L/min.)	37 gpm (140 L/min.)	37 gpm (140 L/min.)	37 gpm (140 L/min.)
Filter, Return Oil	10 micron	10 micron	10 micron	10 micron

Hydraulic System (continued)	750J		750J LT		750J WT		750J LGP
Blade Type	<i>PAT</i>	<i>Outside dozer</i>	<i>PAT</i>	<i>Outside dozer</i>	<i>PAT</i>	<i>Outside dozer</i>	<i>PAT</i>
Control	T-bar hydraulic-pilot two-function joystick with push-button angle function	T-bar hydraulic-pilot two-function joystick	T-bar hydraulic-pilot two-function joystick with push-button angle function	T-bar hydraulic-pilot two-function joystick	T-bar hydraulic-pilot two-function joystick	T-bar hydraulic-pilot two-function joystick	T-bar hydraulic-pilot two-function joystick with push-button angle function
Cylinders	heat-treated, chrome-plated, polished cylinder rods with hardened steel (replaceable bushings) pivot pins	heat-treated, chrome-plated, polished cylinder rods with hardened steel (replaceable bushings) pivot pins	heat-treated, chrome-plated, polished cylinder rods with hardened steel (replaceable bushings) pivot pins	heat-treated, chrome-plated, polished cylinder rods with hardened steel (replaceable bushings) pivot pins	heat-treated, chrome-plated, polished cylinder rods with hardened steel (replaceable bushings) pivot pins	heat-treated, chrome-plated, polished cylinder rods with hardened steel (replaceable bushings) pivot pins	heat-treated, chrome-plated, polished cylinder rods with hardened steel (replaceable bushings) pivot pins
Cooling	convective oil sump	convective oil sump	convective oil sump	convective oil sump	convective oil sump	convective oil sump	convective oil sump

Capacities (U.S.)

Fuel Tank with Lockable Cap.	98 gal. (371 L)	98 gal. (371 L)	98 gal. (371 L)	98 gal. (371 L)	98 gal. (371 L)
Cooling System with Recovery Tank	5.7 gal. (21.5 L)	5.7 gal. (21.5 L)	5.7 gal. (21.5 L)	5.7 gal. (21.5 L)	5.7 gal. (21.5 L)
Engine Lubrication, Including Filter	7.0 gal. (26.5 L)	7.0 gal. (26.5 L)	7.0 gal. (26.5 L)	7.0 gal. (26.5 L)	7.0 gal. (26.5 L)
Final Drive (each)					
1st Reduction	2.1 gal. (8.0 L)	2.1 gal. (8.0 L)	2.1 gal. (8.0 L)	4.0 gal. (15.1 L)	4.0 gal. (15.1 L)
2nd Reduction	4.0 gal. (15.1 L)	4.0 gal. (15.1 L)	4.0 gal. (15.1 L)	4.0 gal. (15.1 L)	4.0 gal. (15.1 L)
Hydraulic System Reservoir	27.9 gal. (105.6 L)	27.9 gal. (105.6 L)	27.9 gal. (105.6 L)	27.9 gal. (105.6 L)	27.9 gal. (105.6 L)
Hydrostatic System Reservoir	27.9 gal. (105.6 L)	27.9 gal. (105.6 L)	27.9 gal. (105.6 L)	27.9 gal. (105.6 L)	27.9 gal. (105.6 L)

Undercarriage

Seven- or eight-roller track frame with front and rear track guides and sprocket guard; John Deere Dura-Trax™ features deep-heat-treated, sealed, and lubricated track links and through-hardened, sealed, and lubricated rollers for maximum wear resistance; sprockets are segmented; extreme-duty shoes are available (on some models) for severe applications

	<i>PAT</i>	<i>Outside dozer</i>	<i>PAT</i>	<i>Outside dozer</i>	<i>PAT</i>
Blade Type	<i>PAT</i>	<i>Outside dozer</i>	<i>PAT</i>	<i>Outside dozer</i>	<i>PAT</i>
Chain	sealed and lubricated	sealed and lubricated	sealed and lubricated	sealed and lubricated	sealed and lubricated
Grouser Width	22 in. (560 mm)	22 in. (560 mm)	22 in. (560 mm)	34 in. (865 mm)	34 in. (865 mm)
Shoes (each side)	40	40	45	40	45
Ground Contact Area	4,488 sq. in. (28 955 cm ²)	4,488 sq. in. (28 955 cm ²)	5,324 sq. in. (34 348 cm ²)	6,936 sq. in. (44 748 cm ²)	8,228 sq. in. (53 084 cm ²)
Ground Pressure	7.24 psi (49.9 kPa)	7.53 psi (51.9 kPa)	6.45 psi (44.4 kPa)	5.24 psi (36.1 kPa)	4.45 psi (30.7 kPa)
Length of Track on Ground	102 in. (2592 mm)	102 in. (2592 mm)	121 in. (3075 mm)	102 in. (2592 mm)	121 in. (3075 mm)
Track Gauge, Standard	74 in. (1880 mm)	74 in. (1880 mm)	74 in. (1880 mm)	84 in. (2134 mm)	84 in. (2134 mm)
Oscillation at Front Roller	±4.3 in. (±110 mm)	±4.3 in. (±110 mm)	±5.3 in. (±135 mm)	±4.7 in. (±120 mm)	±5.0 in. (±127 mm)
Track Rollers (each side)	7	7	8	7	8
Track Pitch	7.5 in. (190.5 mm)	7.5 in. (190.5 mm)	7.5 in. (190.5 mm)	7.5 in. (190.5 mm)	7.5 in. (190.5 mm)

SAE Operating Weights

Base weights were computed for units with standard equipment, rollover protective structures, full fuel tanks, and 175-lb. (79 kg) operators.

Blade Type	<i>PAT</i>	<i>Outside dozer</i>	<i>PAT</i>	<i>Outside dozer</i>	<i>PAT</i>
Base Weight	32,585 lb. (14 778 kg)	33,865 lb. (15 358 kg)	34,395 lb. (15 599 kg)	36,425 lb. (16 519 kg)	36,725 lb. (16 655 kg)

Refer to the Attachment Guide or see your dealer for details regarding Mechanical Angle blades for the 750J LT.

Blade, C-Frame, and Push-Beam Weights

Includes straight end bits.

Blade Type	<i>PAT</i>	<i>Outside dozer</i>	<i>PAT</i>	<i>Outside dozer</i>	<i>PAT</i>
<i>PAT</i>	2,066 lb. (937 kg)*	N/A	2,066 lb. (937 kg)*	N/A	2,383 lb. (1081 kg)*
Semi-U.	N/A	2,564 lb. (1163 kg)*	N/A	2,773 lb. (1258 kg)*	N/A
Straight	N/A	N/A	N/A	2,672 lb. (1212 kg)	N/A
Push Beam Assemblies for Straight or Semi-U Blades (without blade)	N/A	3,242 lb. (1470 kg)*	N/A	3,500 lb. (1588 kg)*	N/A
<i>PAT</i> Dozer C-Frame Assemblies Including Cylinder (without blade)	2,829 lb. (1283 kg)*	N/A	2,905 lb. (1318 kg)*	N/A	2,905 lb. (1318 kg)*

*Included in SAE operating weight.

Refer to the Attachment Guide or see your dealer for details regarding Mechanical Angle blades for the 750J LT.

Blade Capacities

Blade Type	<i>PAT</i>	<i>Outside dozer</i>	<i>PAT</i>	<i>Outside dozer</i>	<i>PAT</i>
<i>PAT</i>	130 in. (3295 mm) 4.23 cu. yd. (3.23 m ³)	N/A	130 in. (3295 mm) 4.23 cu. yd. (3.23 m ³)	N/A	156 in. (3962 mm) 4.98 cu. yd. (3.81 m ³)
Semi-U.	N/A	128 in. (3251 mm) 5.58 cu. yd. (4.27 m ³)	N/A	148 in. (3759 mm) 5.90 cu. yd. (4.51 m ³)	N/A
Straight	N/A	N/A	N/A	150 in. (3810 mm) 5.25 cu. yd. (4.01 m ³)	N/A

Refer to the Attachment Guide or see your dealer for details regarding Mechanical Angle blades for the 750J LT.

Optional or Special Equipment	750J	750J LT	750J WT	750J LGP
Blade Type	PAT	Outside dozer	PAT	Outside dozer
Tracks – Dura-Trax™ Lubricated Chain with Split Master Link, Single-Bar Grousers, and Extended Life Undercarriage				
22-in. (560 mm) Moderate Duty	in base*	in base*	in base*	N/A
22-in. (560 mm) Extreme Duty	263.2 lb. (119.4 kg)	263.2 lb. (119.4 kg)	295.8 lb. (134.2 kg)	N/A
24-in. (610 mm) Moderate Duty	274.8 lb. (124.7 kg)	274.8 lb. (124.7 kg)	308.8 lb. (140.1 kg)	N/A
24-in. (610 mm) Extreme Duty	566 lb. (256.8 kg)	566 lb. (256.8 kg)	636.5 lb. (288.8 kg)	N/A
28-in. (710 mm) Moderate Duty	N/A	N/A	N/A	N/A
34-in. (865 mm) Moderate Duty	N/A	N/A	N/A	– 921.7 lb. (– 418.2 kg)
Cab with Pressurizer and Heater/				
Air Conditioner	743 lb. (337 kg)	743 lb. (337 kg)	743 lb. (337 kg)	743 lb. (337 kg)
Heater (ROPS canopy)	85 lb. (39 kg)	85 lb. (39 kg)	85 lb. (39 kg)	85 lb. (39 kg)
Full-Length Rock Guard	383.9 lb. (174.2 kg)	383.9 lb. (174.2 kg)	340.3 lb. (154.4 kg)	340.3 lb. (154.4 kg)
Final Drive Seal Guard	155 lb. (70 kg)	155 lb. (70 kg)	155 lb. (70 kg)	155 lb. (70 kg)
Retrieval Hitch*	81 lb. (37 kg)	81 lb. (37 kg)	81 lb. (37 kg)	81 lb. (37 kg)
Drawbar, Extended Rigid	286 lb. (130 kg)	286 lb. (130 kg)	286 lb. (130 kg)	286 lb. (130 kg)
Heavy-Duty Grille	62 lb. (28 kg)	62 lb. (28 kg)	62 lb. (28 kg)	62 lb. (28 kg)
Front and Door Screens (ROPS canopy)	186 lb. (84 kg)	186 lb. (84 kg)	186 lb. (84 kg)	186 lb. (84 kg)
Front and Door Screens (cab with air conditioner)	175 lb. (79 kg)	175 lb. (79 kg)	175 lb. (79 kg)	175 lb. (79 kg)
Rear Screen (ROPS canopy)	50 lb. (23 kg)	50 lb. (23 kg)	50 lb. (23 kg)	50 lb. (23 kg)
Rear Screen (cab with air conditioner)	75 lb. (34 kg)	75 lb. (34 kg)	75 lb. (34 kg)	75 lb. (34 kg)
Side Screens (ROPS canopy)	98 lb. (44 kg)	98 lb. (44 kg)	98 lb. (44 kg)	98 lb. (44 kg)
Side Screens (cab with air conditioner)	120 lb. (54 kg)	120 lb. (54 kg)	120 lb. (54 kg)	120 lb. (54 kg)
Condenser Guard (cab with air conditioner)	121 lb. (55 kg)	121 lb. (55 kg)	121 lb. (55 kg)	121 lb. (55 kg)
Limb Risers (ROPS canopy and cab)	575 lb. (261 kg)	575 lb. (261 kg)	575 lb. (261 kg)	575 lb. (261 kg)
Lift-Cylinder Guards	93 lb. (42.2 kg)	170 lb. (77 kg)	93 lb. (42.2 kg)	93 lb. (42.2 kg)
Blade Brush Guard	192 lb. (87 kg)	192 lb. (87 kg)	192 lb. (87 kg)	192 lb. (87 kg)
Tank Guard	712 lb. (323 kg)	712 lb. (323 kg)	712 lb. (323 kg)	712 lb. (323 kg)
Front Counterweight	550 lb. (249 kg)	550 lb. (249 kg)	550 lb. (249 kg)	550 lb. (249 kg)
Rear Counterweight	720 lb. (326 kg)	720 lb. (326 kg)	720 lb. (326 kg)	720 lb. (326 kg)

*Included in SAE operating weight.

Dimensions

	PAT	Outside dozer	PAT	Outside dozer	PAT
Blade Type	PAT	Outside dozer	PAT	Outside dozer	PAT
A Overall Height to Roof	122 in. (3095 mm)	122 in. (3095 mm)	122 in. (3095 mm)	122 in. (3095 mm)	122 in. (3095 mm)
Overall Height to Exhaust Stack	119 in. (3020 mm)	119 in. (3020 mm)	119 in. (3020 mm)	119 in. (3020 mm)	119 in. (3020 mm)
B Tread Depth with Single-Bar Grouser					
Moderate Duty	2.2 in. (56 mm)	2.2 in. (56 mm)	2.2 in. (56 mm)	2.2 in. (56 mm)	2.2 in. (56 mm)
Extreme Duty	2.7 in. (68 mm)	2.7 in. (68 mm)	2.7 in. (68 mm)	2.7 in. (68 mm)	2.7 in. (68 mm)
C Ground Clearance with Grousers (excludes grouser height)	14 in. (356.9 mm)	14 in. (356.9 mm)	14 in. (356.9 mm)	14 in. (356.9 mm)	14 in. (356.9 mm)
D Blade Width	129.75 in. (3296 mm)	128 in. (3251 mm)	129.75 in. (3296 mm)	148 in. (3759 mm)	156 in. (3962 mm)
E Blade Height	47 in. (1194 mm)	48.8 in. (1240 mm)	47 in. (1194 mm)	46.1 in. (1170 mm)	46.1 in. (1170 mm)
F Blade Lift Height	38.5 in. (979 mm)	41.3 in. (1050 mm)	40.3 in. (1025 mm)	41.3 in. (1050 mm)	40.3 in. (1025 mm)
G Blade Digging Depth	24.4 in. (620 mm)	22.6 in. (575 mm)	25.6 in. (650 mm)	22.6 in. (575 mm)	25.6 in. (650 mm)
H Blade Tilt (uses tilt jack)	17.2 in. (437 mm)	28.4 in. (722 mm)	17.2 in. (437 mm)	25.7 in. (653 mm)	20.6 in. (524 mm)
I Overall Length with Blade*	196.5 in. (4990 mm)	205 in. (5205 mm)	208.5 in. (5300 mm)	205 in. (5205 mm)	208.5 in. (5300 mm)
J Overall Width with Blade Angled	118.9 in. (3020 mm)	N/A	118.9 in. (3020 mm)	N/A	142.9 in. (3631 mm)
K Blade Angle	23.5 degrees	N/A	23.5 degrees	N/A	23.5 degrees
L Cut Reach	4.3 in. (108 mm)	N/A	4.3 in. (108 mm)	N/A	3.3 in. (84 mm)
M Width Over Track	96 in. (2438 mm)	96 in. (2438 mm)	96 in. (2438 mm)	118 in. (2997 mm)	118 in. (2997 mm)
N Cast Reach	8.8 in. (224 mm)	N/A	8.8 in. (224 mm)	N/A	11.7 in. (297 mm)
O Cutting Edge Angle	55.2–60.1 degrees	50.5–60.0 degrees	55.2–60.1 degrees	50.5–60.0 degrees	55.2–60.1 degrees

*Optional extended drawbar adds 11 in. (279.5 mm).

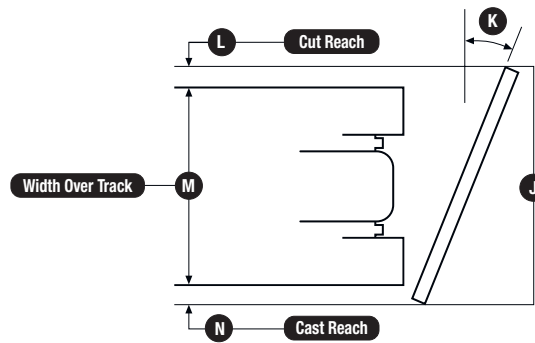
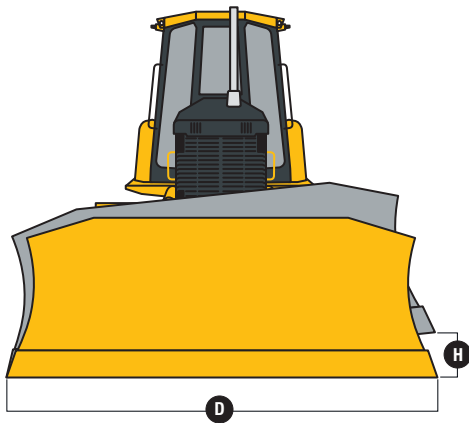
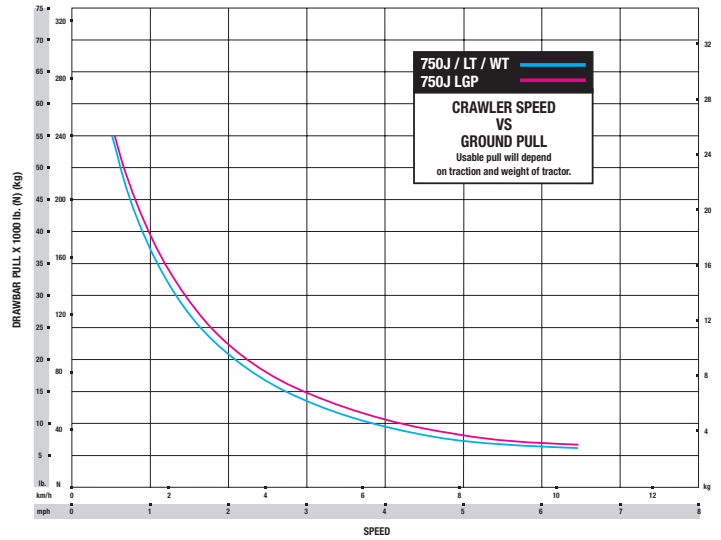
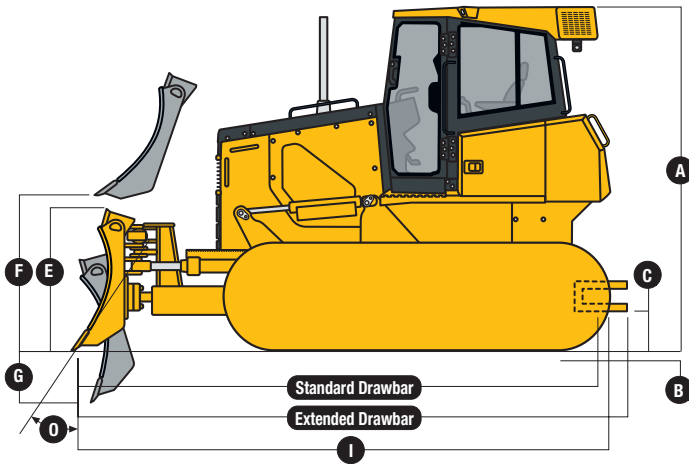

Parallelogram Ripper with Hydraulic Pitch Adjustment and ESCO Ripper Tips

750J

multi-shank (3)

- Weight 3,725 lb. (1690 kg)
- P** Maximum penetration 27 in. (685 mm)
- Q** Maximum clearance under tip 27 in. (685 mm)
- R** Overall length, lowered position 66.5 in. (1685 mm)
- R'** Overall length, raised position 57 in. (1445 mm)
- S** Overall beam width 84 in. (2135 mm)
- T** Slope angle (full raise) 22 degrees
- U** Ripping width 74 in. (1880 mm)
- V** Distance between shanks 35.5 in. (905 mm)

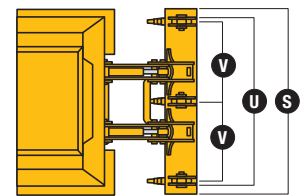
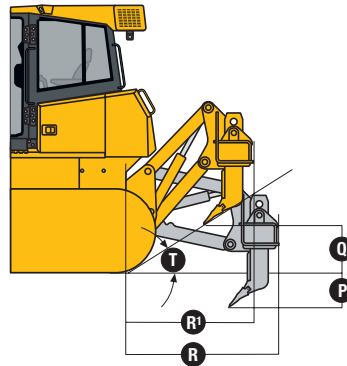

Specifications

850J



Engine	850J	850J LT	850J WT	850J WLT	850J LGP
Type	John Deere PowerTech Plus™ 6090HT with variable-geometry turbocharger, exhaust gas recirculation, and air-to-air aftercooler; certified to EPA Tier 3 emissions	John Deere PowerTech Plus 6090HT with variable-geometry turbocharger, exhaust gas recirculation, and air-to-air aftercooler; certified to EPA Tier 3 emissions	John Deere PowerTech Plus 6090HT with variable-geometry turbocharger, exhaust gas recirculation, and air-to-air aftercooler; certified to EPA Tier 3 emissions	John Deere PowerTech Plus 6090HT with variable-geometry turbocharger, exhaust gas recirculation, and air-to-air aftercooler; certified to EPA Tier 3 emissions	John Deere PowerTech Plus 6090HT with variable-geometry turbocharger, exhaust gas recirculation, and air-to-air aftercooler; certified to EPA Tier 3 emissions
Rated Power @ 1,800 rpm	185 SAE net hp (137 kW) / 192 SAE gross hp (143 kW)	185 SAE net hp (137 kW) / 192 SAE gross hp (143 kW)	185 SAE net hp (137 kW) / 192 SAE gross hp (143 kW)	185 SAE net hp (137 kW) / 192 SAE gross hp (143 kW)	200 SAE net hp (151 kW) / 210 SAE gross hp (157 kW)
Cylinders	6	6	6	6	6
Displacement	550 cu. in. (9.0 L)	550 cu. in. (9.0 L)	550 cu. in. (9.0 L)	550 cu. in. (9.0 L)	550 cu. in. (9.0 L)
Maximum Net Torque @ 1,500 rpm	611 lb.-ft. (828 Nm)	611 lb.-ft. (828 Nm)	611 lb.-ft. (828 Nm)	611 lb.-ft. (828 Nm)	675 lb.-ft. (915 Nm)
Lubrication	pressure system with full-flow spin-on filter and oil-to-water cooler	pressure system with full-flow spin-on filter and oil-to-water cooler	pressure system with full-flow spin-on filter and oil-to-water cooler	pressure system with full-flow spin-on filter and oil-to-water cooler	pressure system with full-flow spin-on filter and oil-to-water cooler
Air Cleaner	dual-stage dry type with tangential unloader	dual-stage dry type with tangential unloader	dual-stage dry type with tangential unloader	dual-stage dry type with tangential unloader	dual-stage dry type with tangential unloader
Electrical System	24 volt with 80-amp alternator (cab), 55-amp alternator (canopy)	24 volt with 80-amp alternator (cab), 55-amp alternator (canopy)	24 volt with 80-amp alternator (cab), 55-amp alternator (canopy)	24 volt with 80-amp alternator (cab), 55-amp alternator (canopy)	24 volt with 80-amp alternator (cab), 55-amp alternator (canopy)
Batteries (two 12-volt)	950 cold-cranking amps, 190-min. reserve capacity	950 cold-cranking amps, 190-min. reserve capacity	950 cold-cranking amps, 190-min. reserve capacity	950 cold-cranking amps, 190-min. reserve capacity	950 cold-cranking amps, 190-min. reserve capacity
Cooling Fan	variable-speed suction	variable-speed suction	variable-speed suction	variable-speed suction	variable-speed suction
Cooling Fan Filter, Return Oil	10 micron	10 micron	10 micron	10 micron	10 micron

Transmission

Automatic, dual-path, hydrostatic drive; load-sensing feature automatically adjusts speed and power to match changing load conditions; each individually controlled track is powered by a variable-displacement piston pump and motor combination; travel speeds (forward and reverse) infinite to 6.3 mph (0 to 10 km/h); ground-speed selection buttons on single-lever steering and direction control; independently selectable reverse speed ratios 80%, 100%, 115%, or 130% of forward ground speed; decelerator pedal controls ground speed to dead stop

Type	dual-path hydrostatic
System Relief Pressure	6,650 psi (45 850 kPa)
Filter, Charge Oil	10 micron
Cooling	oil-to-air
Travel Speeds (forward and reverse)	0–6.3 mph (0–10 km/h) / 6.8 mph (11 km/h) max. (optional)

Final Drives

Double-reduction, planetary final drives transfer torque loads over three gear sets; mounted independently of track frames and dozer push frames for isolation from shock loads

Total Ratio	44.7483 to 1	44.7483 to 1	44.7483 to 1	44.7483 to 1	44.7483 to 1
Drawbar Pull					
Maximum	77,300 lb. (344 kN)	77,300 lb. (344 kN)	77,300 lb. (344 kN)	77,300 lb. (344 kN)	77,300 lb. (344 kN)
@ 1.2 mph (1.9 km/h)	37,500 lb. (167 kN)	37,500 lb. (167 kN)	37,500 lb. (167 kN)	37,500 lb. (167 kN)	40,000 lb. (178 kN)
@ 2.0 mph (3.2 km/h)	27,000 lb. (120 kN)	27,000 lb. (120 kN)	27,000 lb. (120 kN)	27,000 lb. (120 kN)	29,500 lb. (131 kN)

Steering

Single-lever steering, speed, direction control, and counterrotation; full power turns and infinitely variable track speeds provide unlimited maneuverability and optimum control; hydrostatic steering eliminates steering clutches and brakes

Brakes

Hydrostatic (dynamic) braking stops machine when the direction/steering control lever is moved to neutral or the decelerator is depressed to the end of travel

Type	hydraulic
------	-----------

Automatic Parking Brake

Exclusive safety feature engages wet, multiple-disc brakes whenever the engine stops, whenever the decelerator is depressed to the end of travel, or whenever the park lock lever is placed in the start or neutral positions and motion is detected; machine cannot be driven with brake applied, reducing wear out or need for adjustment

Type	spring-applied, hydraulic release
------	-----------------------------------

Hydraulic System

System Type	load sense	load sense	load sense	load sense	load sense
System Relief Pressure	3,625 psi (25 000 kPa)	3,625 psi (25 000 kPa)	3,625 psi (25 000 kPa)	3,625 psi (25 000 kPa)	3,625 psi (25 000 kPa)
Differential Pressure	275 psi (1900 kPa)	275 psi (1900 kPa)	275 psi (1900 kPa)	275 psi (1900 kPa)	275 psi (1900 kPa)
Pump Type	piston	piston	piston	piston	piston
Pump (74 cc)	46 gpm (174 L/min.)	46 gpm (174 L/min.)	46 gpm (174 L/min.)	46 gpm (174 L/min.)	46 gpm (174 L/min.)
Maximum Flow @ Unloaded High Idle	43 gpm (163 L/min.)	43 gpm (163 L/min.)	43 gpm (163 L/min.)	43 gpm (163 L/min.)	43 gpm (163 L/min.)
Filter, Return Oil	10 micron	10 micron	10 micron	10 micron	10 micron

Optional or Special Equipment	850J	850J LT	850J WT	850J WLT	850J LGP	
Blade Type	<i>Outside dozer</i>	<i>PAT</i>	<i>Outside dozer</i>	<i>PAT</i>	<i>PAT</i>	<i>Outside dozer</i>
Tracks – Dura-Trax™ Lubricated Chain with Split Master Link, Single-Bar Grousers, and Extended Life Undercarriage						
22-in. (560 mm) Extreme Duty	341.4 lb. (154.9 kg)	383.9 lb. (174.2 kg)	– 482 lb. (– 218.7 kg)	N/A	N/A	N/A
24-in. (610 mm) Moderate Duty	in base*	in base*	– 823.4 lb. (– 373.6 kg)	N/A	– 1,867.7 lb. (– 847.4 kg)	– 1,867.7 lb. (– 847.4 kg)
24-in. (610 mm) Extreme Duty	675.5 lb. (306.5 kg)	759.9 lb. (344.8 kg)	– 147.9 lb. (– 67.1 kg)	N/A	– 1,107.7 lb. (– 502.6 kg)	– 1,107.7 lb. (– 502.6 kg)
30-in. (760 mm) Moderate Duty	N/A	N/A	in base*	in base*	– 941.5 lb. (– 427.2 kg)	N/A
30-in. (760 mm) Extreme Duty	N/A	N/A	854.5 lb. (387.7 kg)	961.4 lb. (436.2 kg)	19.8 lb. (9 kg)	N/A
36-in. (910 mm) Moderate Duty	N/A	N/A	N/A	N/A	in base*	in base*
36-in. (910 mm) Extreme Duty	N/A	N/A	N/A	N/A	1,152.9 lb. (523.1 kg)	1,152.9 lb. (523.1 kg)
Cab with Pressurizer and Heater/						
Air Conditioner	743 lb. (337 kg)	743 lb. (337 kg)	743 lb. (337 kg)	743 lb. (337 kg)	743 lb. (337 kg)	743 lb. (337 kg)
Heater (ROPS canopy)	85 lb. (39 kg)	85 lb. (39 kg)	85 lb. (39 kg)	85 lb. (39 kg)	85 lb. (39 kg)	85 lb. (39 kg)
Full-Length Rock Guard	534 lb. (224.3 kg)	490.2 lb. (222.4 kg)	534 lb. (224.3 kg)	490.2 lb. (222.4 kg)	490.2 lb. (222.4 kg)	490.2 lb. (222.4 kg)
Final Drive Seal Guard	155 lb. (70 kg)	155 lb. (70 kg)	155 lb. (70 kg)	155 lb. (70 kg)	155 lb. (70 kg)	155 lb. (70 kg)
Retrieval Hitch*	114 lb. (52 kg)	114 lb. (52 kg)	114 lb. (52 kg)	114 lb. (52 kg)	114 lb. (52 kg)	114 lb. (52 kg)
Drawbar, Extended Rigid	286 lb. (130 kg)	286 lb. (130 kg)	286 lb. (130 kg)	286 lb. (130 kg)	286 lb. (130 kg)	286 lb. (130 kg)
Heavy-Duty Grille	86 lb. (39 kg)	86 lb. (39 kg)	86 lb. (39 kg)	86 lb. (39 kg)	86 lb. (39 kg)	86 lb. (39 kg)
Front and Door Screens (ROPS canopy)	186 lb. (84 kg)	186 lb. (84 kg)	186 lb. (84 kg)	186 lb. (84 kg)	186 lb. (84 kg)	186 lb. (84 kg)
Front and Door Screens (cab with air conditioner)	175 lb. (79 kg)	175 lb. (79 kg)	175 lb. (79 kg)	175 lb. (79 kg)	175 lb. (79 kg)	175 lb. (79 kg)
Rear Screen (ROPS canopy)	50 lb. (23 kg)	50 lb. (23 kg)	50 lb. (23 kg)	50 lb. (23 kg)	50 lb. (23 kg)	50 lb. (23 kg)
Rear Screen (cab with air conditioner)	75 lb. (34 kg)	75 lb. (34 kg)	75 lb. (34 kg)	75 lb. (34 kg)	75 lb. (34 kg)	75 lb. (34 kg)
Side Screens (ROPS canopy)	98 lb. (44 kg)	98 lb. (44 kg)	98 lb. (44 kg)	98 lb. (44 kg)	98 lb. (44 kg)	98 lb. (44 kg)
Side Screens (cab with air conditioner)	120 lb. (54 kg)	120 lb. (54 kg)	120 lb. (54 kg)	120 lb. (54 kg)	120 lb. (54 kg)	120 lb. (54 kg)
Condenser Guard (cab with air conditioner)	121 lb. (55 kg)	121 lb. (55 kg)	121 lb. (55 kg)	121 lb. (55 kg)	121 lb. (55 kg)	121 lb. (55 kg)
Limb Risers (ROPS canopy and cab)	600 lb. (272 kg)	600 lb. (272 kg)	600 lb. (272 kg)	600 lb. (272 kg)	600 lb. (272 kg)	600 lb. (272 kg)
Lift-Cylinder Guards	176 lb. (80 kg)	93 lb. (42.2 kg)	176 lb. (80 kg)	93 lb. (42.2 kg)	93 lb. (42.2 kg)	176 lb. (80 kg)
Blade Brush Guard	192 lb. (87 kg)	192 lb. (87 kg)	192 lb. (87 kg)	192 lb. (87 kg)	192 lb. (87 kg)	192 lb. (87 kg)
Tank Guard	712 lb. (323 kg)	712 lb. (323 kg)	712 lb. (323 kg)	712 lb. (323 kg)	712 lb. (323 kg)	712 lb. (323 kg)
Front Counterweight	875 lb. (397 kg)	875 lb. (397 kg)	875 lb. (397 kg)	875 lb. (397 kg)	875 lb. (397 kg)	875 lb. (397 kg)
Rear Counterweight	990 lb. (449 kg)	990 lb. (449 kg)	990 lb. (449 kg)	990 lb. (449 kg)	990 lb. (449 kg)	990 lb. (449 kg)

*Included in SAE operating weight.

Dimensions

	850J	850J LT	850J WT	850J WLT	850J LGP	
Blade Type	<i>Outside dozer</i>	<i>PAT</i>	<i>Outside dozer</i>	<i>PAT</i>	<i>PAT</i>	<i>Outside dozer</i>
A Overall Height to Roof	125 in. (3180 mm)	125 in. (3180 mm)	125 in. (3180 mm)	125 in. (3180 mm)	125 in. (3180 mm)	125 in. (3180 mm)
Overall Height to Exhaust Stack	125.5 in. (3190 mm)	125.5 in. (3190 mm)	125.5 in. (3190 mm)	125.5 in. (3190 mm)	125.5 in. (3190 mm)	125.5 in. (3190 mm)
B Tread Depth with Single-Bar Grouser						
Moderate Duty	2.6 in. (65 mm)	2.6 in. (65 mm)	2.6 in. (65 mm)	2.6 in. (65 mm)	2.6 in. (65 mm)	2.6 in. (65 mm)
Extreme Duty	2.8 in. (72 mm)	2.8 in. (72 mm)	2.8 in. (72 mm)	2.8 in. (72 mm)	2.8 in. (72 mm)	2.8 in. (72 mm)
C Ground Clearance with Grousers (excludes grouser height)	16.1 in. (408.5 mm)	16.1 in. (408.5 mm)	16.1 in. (408.5 mm)	16.1 in. (408.5 mm)	16.1 in. (408.5 mm)	16.1 in. (408.5 mm)
D Blade Width	128 in. (3251 mm)	146 in. (3708 mm)	140 in. (3556 mm)	158 in. (4013 mm)	168 in. (4267 mm)	152 in. (3861 mm)
E Blade Height	56 in. (1422 mm)	48.4 in. (1230 mm)	54.1 in. (1375 mm)	48.4 in. (1230 mm)	48.4 in. (1230 mm)	52 in. (1320 mm)
F Blade Lift Height	45.3 in. (1150 mm)	42.2 in. (1071 mm)	45.3 in. (1150 mm)	42.2 in. (1071 mm)	42.2 in. (1071 mm)	45.3 in. (1150 mm)
G Blade Digging Depth	23.6 in. (600 mm)	27.7 in. (703 mm)	23.6 in. (600 mm)	27.7 in. (703 mm)	27.7 in. (703 mm)	23.6 in. (600 mm)
H Blade Tilt (uses tilt jack)	29.6 in. (753 mm)	19.6 in. (498 mm)	29.6 in. (753 mm)	21.2 in. (538 mm)	22.5 in. (572 mm)	33.6 in. (854 mm)
I Overall Length with Blade*	212 in. (5377 mm)	225.5 in. (5726 mm)	212 in. (5377 mm)	225.5 in. (5726 mm)	225.5 in. (5726 mm)	234 in. (5940 mm)
J Overall Width with Blade Angled	N/A	133.5 in. (3390 mm)	N/A	144 in. (3658 mm)	153.6 in. (3901 mm)	N/A

*Optional extended drawbar adds 9.5 in. (241.5 mm).

Dimensions (continued)	850J	850J LT	850J WT	850J WLT	850J LGP	850J LGP
Blade Type	Outside dozer	PAT	Outside dozer	PAT	PAT	Outside dozer
K Blade Angle	N/A	23.8 degrees	N/A	23.8 degrees	23.8 degrees	N/A
L Cut Reach	N/A	6.2 in. (158 mm)	N/A	5.7 in. (145 mm)	4.3 in. (109 mm)	N/A
M Width Over Track	98 in. (2489.2 mm)	106 in. (2692.4 mm)	110 in. (2794 mm)	118 in. (2997.2 mm)	130 in. (3302 mm)	122 in. (3098.8 mm)
N Cast Reach	N/A	11.2 in. (284 mm)	N/A	10.7 in. (271 mm)	9.2 in. (234 mm)	N/A
O Cutting Edge Angle	51.5–61.0 degrees	55.1–60.2 degrees	51.5–61.0 degrees	55.1–60.2 degrees	55.1–60.2 degrees	51.5–61.0 degrees

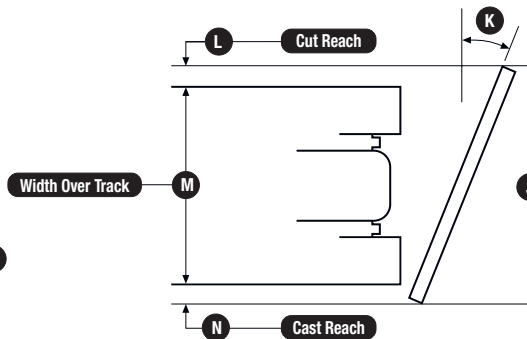
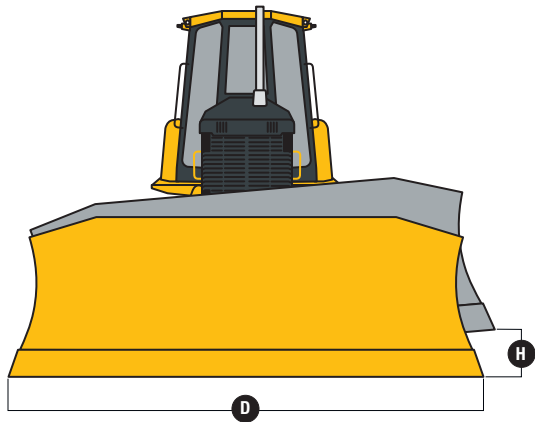
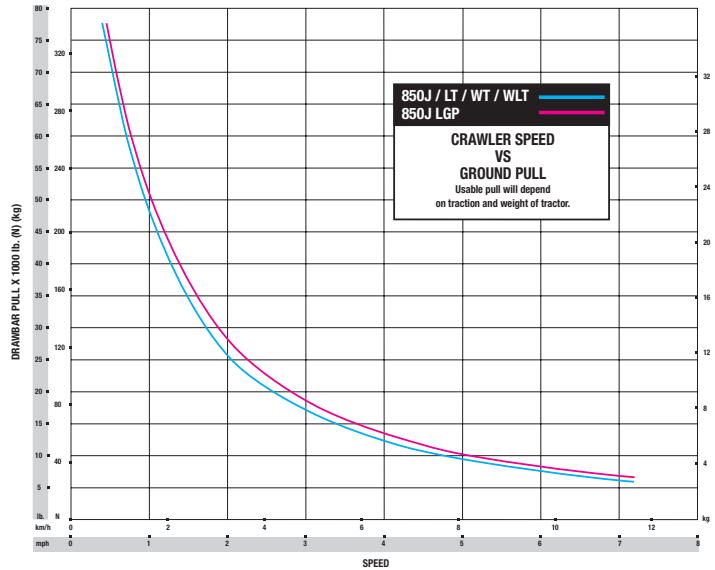
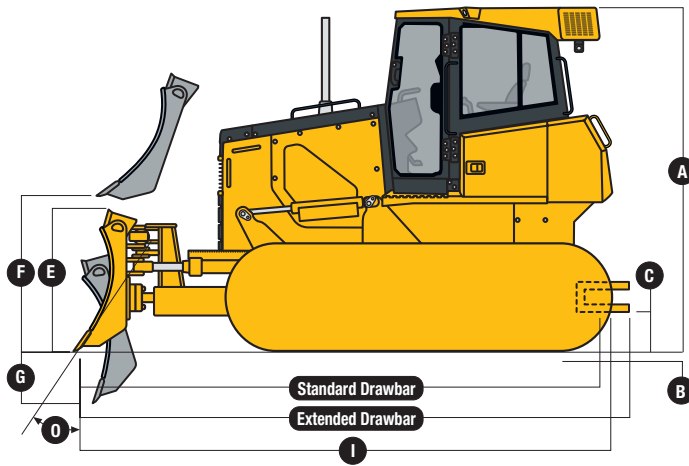

Parallelogram Ripper with Hydraulic Pitch Adjustment and ESCO Ripper Tips

850J
multi-shank (3)

- Weight 4,480 lb. (2032 kg)
- P** Maximum penetration 28.5 in. (725 mm)
- Q** Maximum clearance under tip 24 in. (610 mm)
- R** Overall length, lowered position 64 in. (1625 mm)
- R'** Overall length, raised position 60 in. (1525 mm)
- S** Overall beam width 94.5 in. (2400 mm)
- T** Slope angle (full raise) 24 degrees
- U** Ripping width 84.5 in. (2145 mm)
- V** Distance between shanks 41 in. (1040 mm)

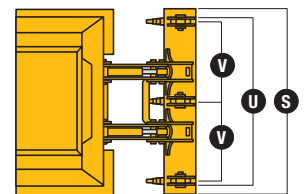
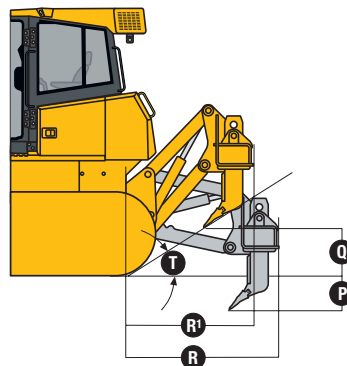

750J / 850J CRAWLER DOZERS

Key: ● Standard equipment ▲ Optional or special equipment

*See your John Deere dealer for further information.

750J 850J Engine

- Certified to EPA Tier 2 emissions
- Certified to EPA Tier 3 emissions
- Electronic control with automatic engine protection
- Dual safety element dry-type air cleaner, evacuator valve
- Muffler, self draining, under hood, with vertical stack
- Environmental service drains
- ▲ Ether start aid
- ▲ Chrome exhaust
- ▲ Rotary ejector engine air precleaner

Cooling

- Cooling fan, suction type
- ▲ Cooling fan, suction type, programmable reversing
- Engine coolant radiator (10 fins per in.)
- Engine coolant radiator (6 fins per in.)
- Hydrostatic cooler (oil/air – 10 fins per in.)
- Hydrostatic cooler (oil/air – 6 fins per in.)
- Hydraulic cooler (oil/air – 6 fins per in.)
- Enclosed safety fan guard (conforms to SAE J1308 and ISO3457)
- Perforated engine side shields
- Split-hinge bar-type grille
- ▲ Extreme-duty grille

Transmission

- Diagnostic test ports
- Environmental service drains
- ▲ Final-drive seal guards

Hydraulic System

- Two-function hydraulics
- ▲ Three-function hydraulics
- ▲ Four-function hydraulics with rear plumbing
- ▲ High-flow hydraulic pump and hydraulic cooler for use with winch

Mainframe, Access Panels

- Tilt operator station transmission access
- Front tow loop (bolt-on)
- Integral bottom protection
- Hinged bottom access covers (bolt-on)
- Vandal protection: Engine access door / Side tank access doors / Fuel tank / Instrument panel / Transmission reservoir / Hydraulic reservoir
- Maintenance-free center crossbar pivot

750J 850J Attachments

- ▲ Retrieval hitch with pin
- ▲ Extended rigid drawbar with pin for pull-type implements
- ▲ Counterweight, rear, 720 lb. (327 kg)
- ▲ Counterweight, rear, 1,000 lb. (454 kg)
- ▲ Ripper, rear, three shank
- ▲ Winch, hydrostatically driven*
- ▲ Forestry screens*

Undercarriage

- Oscillating undercarriage with remote lube
- Full-length, smooth-surface track frame covers
- Guides, front and rear, with bolt-on wear strips
- Segmented sprockets
- Double-flange rollers
- ▲ Full-length rock guards

Canopy Cab Operator's Station / Electrical

- Retractable seat belts, 3 in. (76 mm) (conforms to SAE J386)
- Convex interior rearview mirror, 4-in. (102 mm) tall, 8-in. (203 mm) wide (conforms to SAE J985)
- Power port, 12 volts
- ▲ Second power port, 12 volts
- Lockable dash-mounted storage compartment
- Air conditioner, 24,000 Btu
- Tinted glass
- Dome light
- Heater (roof mount)
- Front and door wipers
- Mechanical suspension vinyl seat
- Mechanical suspension fabric seat
- ▲ Air suspension vinyl seat
- ▲ Air suspension fabric seat
- ▲ Under-seat heater
- ▲ Rear wiper, two speed
- ▲ AM/FM, weather-band radio, clock
- ▲ External-mounted attachment mirror
- Sealed alternator, 55 amps
- Master electrical disconnect switch
- Lights, grille mounted (2), rear mounted (1)
- ▲ Work lights (4), roof mounted

CONTROL OWNING AND OPERATING COSTS

Customer Personal Service (CPS) is part of John Deere's proactive, fix-before-fail strategy on machine maintenance that will help control costs, increase profits, and reduce stress. Included in this comprehensive lineup of ongoing programs and services are:

Fluid analysis program – tells you what's going on inside *all* of your machine's major components so you'll know if there's a problem *before* you see a decline in performance. Fluid analysis is included in most extended coverage and preventive-maintenance agreements.

Component life-cycle data – gives you vital information on the projected life span of components and lets you make informed decisions on machine maintenance by telling you approximately how many hours of use you can expect from an engine, transmission, or hydraulic pump. This information can be used to preempt catastrophic downtime by servicing major components at about 80 percent of their life cycle.

Preventive Maintenance (PM) agreements – give you a fixed cost for maintaining a machine for a given period of time. They also help you avoid downtime by ensuring that critical maintenance work gets done right and on schedule. On-site preventive maintenance service performed where and when you need it helps protect you from the expense of catastrophic failures and lets you avoid waste-disposal hassles.

Extended coverage – gives you a fixed cost for machine repairs for a given period of time so you can effectively manage costs. Whether you work in a severe-service setting or just want to spread the risk of doing business, this is a great way to custom-fit coverage for your operation. And an extended coverage contract also travels well because it's backed by John Deere and is honored by *all* Deere construction dealers.

Customer Support Advisors (CSAs) – Deere believes the CSA program lends a *personal* quality to Customer Personal Service (CPS). Certified CSAs have the knowledge and skills for helping make important decisions on machine maintenance and repair. Their mission is to help you implement a plan that's right for *your* business and take the burden of machine maintenance off your shoulders.



JOHN DEERE

DKAJGDZR Litho in U.S.A. (06-06)

Net engine power is with standard equipment including air cleaner, exhaust system, alternator, and cooling fan, at standard conditions per SAE J1349 and DIN 6270B, using No. 2-D fuel at 35 API gravity. No derating is required up to 10,000-ft. (3050 m) altitude. Gross power is without cooling fan.

Also available: winches, fair-leads, log arches, skidding grapples, trash packages, landfill protection packages, cable plows, side booms, field-installed cab for canopy, canopy heater, and fire suppression systems.

Specifications and design subject to change without notice. Wherever applicable, specifications are in accordance with SAE standards. Except where otherwise noted, these specifications are based on units with rollover protective structures, full fuel tanks, 175-lb. (79 kg) operators, and standard equipment; 750J LT unit with 22-in. (560 mm) moderate-duty grousers, rigid drawbar, and Semi-U (High-Production) blade; and 750J WT and LGP units with 34-in. (865 mm) single-bar grousers and rigid drawbars.

