

Inboard Machine

Exclusive machine provided with measures to counter dust and fire

- Superior combined operation of front attachment and swing conduce to higher productivity than that of trimming dozers.
- An emission control engine and a low-noise, large-capacity muffler are mounted.
- Various measures are provided to counter dust and fire.

● Example of Equipment ●



● Increased durability and productivity with Swedish-steel bucket

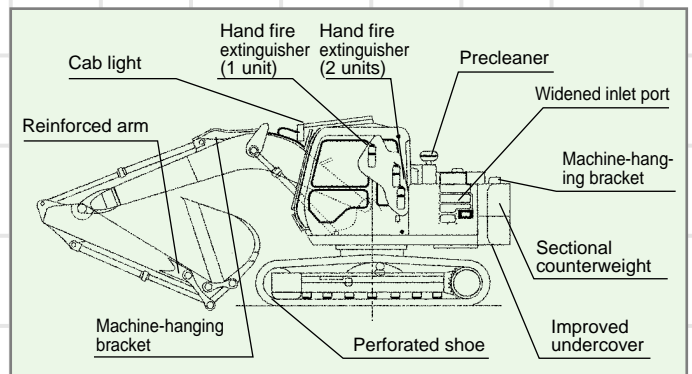
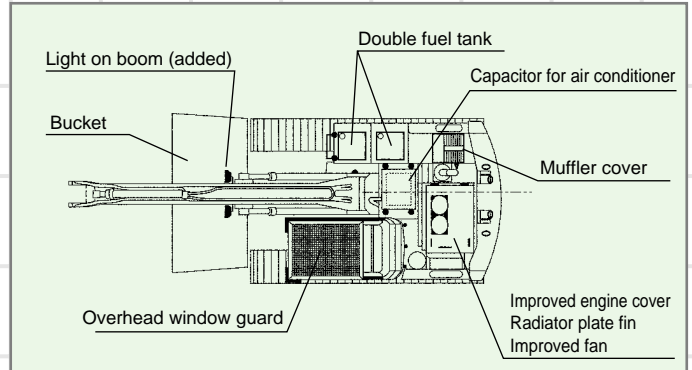

● Options ●

Items	Purpose	Remarks
Glass for overhead window	Visibility up	
Guards for front and overhead glass	Safety up	
Bucket	Productivity up	1.8m ³ , light type, Sweden steel
Reinforced arm (4 plates)	Durability up	1.8m ³ , light type, Sweden steel
Machine-hanging bracket	Increased hanging capacity	Boom X 2, Counterweight X 2
Boom step for reeving		Machine total weight: 12 400kg (11 200kg+1 200kg)
Sectional counterweight	Safety up	
Increased number of lights		Boom (right) X 1, Cab roof X 2
Increased battery capacity	Productivity up	(Conventional)80D (New) 95D
Increased number of fuel tanks		Total: 500L
Fuel tank double filter		Prevention of fuel contamination
Precleaner		Prevention of dust suction
Perforated shoe	Heat balance up	Prevention of shoe link clogging
Enlarged radiator inlet port		Increase of engine cooling airflow
Enlarged radiator outlet port		
Large-size engine fan		
Improved undercover		
Plate-fin radiator	Fire prevention	Superior performance to wavy fin
Separated air conditioner capacitor		Easier radiator cleaning
Ceramic-clothed muffler		Prevention of dust entrance
Covered muffler		
Sealed engine cover		
Hand fire extinguisher	CabX1, Engine roomX2	



● The air-jetting device on the arm top makes shelf breaking work easy and ensures increased safety.