

B30D 6x6 ARTICULATED DUMP TRUCK Mk VI



Gross Power: 240 kw (322 hp)
Gross Torque: 1 250 Nm (922 lbft)
Rated Payload: 27 300 kg (60,186 lbs)



B30D 6x6 ARTICULATED DUMP TRUCK MKVI

ENGINE Mercedes Benz inline 6 cylinder, turbocharged, intercooled, low emission diesel engine

Gross power 240 kW (322 hp) @ 2,200 - 1,600 rpm

Net Power 232 kW (311 hp) @ 2,200 - 1,600 rpm

Gross torque 1,250 Nm (922 lbf) @ 1,200 - 1,600 rpm

Net torque 1,200 Nm (885 lbf) @ 1,200 - 1,600 rpm

Displacement 7,2 litres (439 cu.in)

Fuel tank capacity 340 l (90 US gal)

Auxiliary Brake Exhaust brake
Engine Valve Brake (EVB)

Certification
Non Regulated OM 926 LA.11 1/4-00 meets Europe (EU) step 2;
Regulated OM 926 LA.E3A/1 meets Europe (EU) step 3

TRANSMISSION Engine mounted, fully automatic ZF planetary transmission with six forward gears and one reverse gear.

Torque Converter Hydrodynamic with lock-up in all gears.

Model 6HP592C Ecomat 2 Plus

Control Type Electronic

TRANSFER BOX Remote mounted

Manufacturer VGR

Model 13100

Layout Three in-line helical gears.

Output Differential 67/33 torque proportioning, Pneumatically lockable on the move.

AXLES High strength steel fabricated with spiral bevel type gears on the limited slip locking differential and heavy duty outboard planetary gears.

Model Bell 18T

BRAKING SYSTEM

SERVICE BRAKE Dual circuit, full hydraulic actuation caliper brakes on all wheels

Maximum brake force PARK & EMERGENCY 164 kN (36,900 lbf)

Maximum brake force AUXILIARY BRAKE 396 kN (89,000 lbf)

Spring applied, air released driveline mounted disc.
Automatic exhaust brake and Engine Valve Brake (EVB)
Variable Adjustable Hydraulic Retarder

Maximum retardation 442 kW (593 hp)



WHEELS Earthmover
Tyre 23.5R25

FRONT SUSPENSION Semi-independent, quad rubber mounted leading arm linkages supported by nitrogen and oil filled struts.

REAR SUSPENSION Pivoting walking beams, distributing equal load through laminated rubber suspension blocks. Each axle is coupled to the chassis by four rubber-bushed links for ideal vertical movement.

HYDRAULIC SYSTEM Variable displacement with load sensing system incorporating a ground driven emergency steering pump.

Flow 184 l/min (48.6 gal/min)

Pressure 25 Mpa (3,915 psi)

Filter 5 micron

STEERING SYSTEM Hydrostatically actuated, low effort, fast acting.
Two double-acting steering cylinders

Lock to lock turns 4.1

Steering Angle +-45°

DUMPING SYSTEM Two double-acting, single stage, dump cylinders

Raise Time 12 s

Lowering Time 6 s

Tipping Angle 70°

PNEUMATIC SYSTEM Air drier with heater and integral unloader valve, serving park brake and auxiliary functions

System Pressure 850 kPa (123 psi)

ELECTRICAL SYSTEM

Voltage 24 V

Battery Type Two maintenance free permanently sealed

Battery Capacity 2 X 105 Ah

Alternator Rating 28 V 80 A

VEHICLE SPEEDS

1st	8	5
2nd	13	8
3rd	22	14
4th	31	19
5th	44	28
6th	53	33
R	8 km/h	5 mph



B30D 6x6 ARTICULATED DUMP TRUCK MKVI

LOAD CAPACITY & GROUND PRESSURE

WEIGHTS			GROUND PRESSURE			LOAD CAPACITY		
UNLADEN	kg	lbs	UNLADEN	kPa	psi	BODY	m ³	cu.yd
Front	9,710	21,407	Front	95	13.8	Struck Capacity	13	17
Middle	4,490	9,899	Middle	47	6.8	SAE 2:1 Capacity	17	22.2
Rear	4,490	9,899	Rear	46	6.7	SAE 1:1 Capacity	20,5	26.8
Total	18,690	41,204	Total			SAE 2:1 Capacity with Autogate	17,5	22.9
LADEN			LADEN					
Front	13,350	29,432	Front	264	38.2			
Middle	16,320	35,979	Middle	332	48.1	Rated Payload	27,300 kg	60,186 lbs
Rear	16,320	35,979	Rear	332	48.1			
Total	45,990	101,391						

GRADEABILITY/RIMPULL

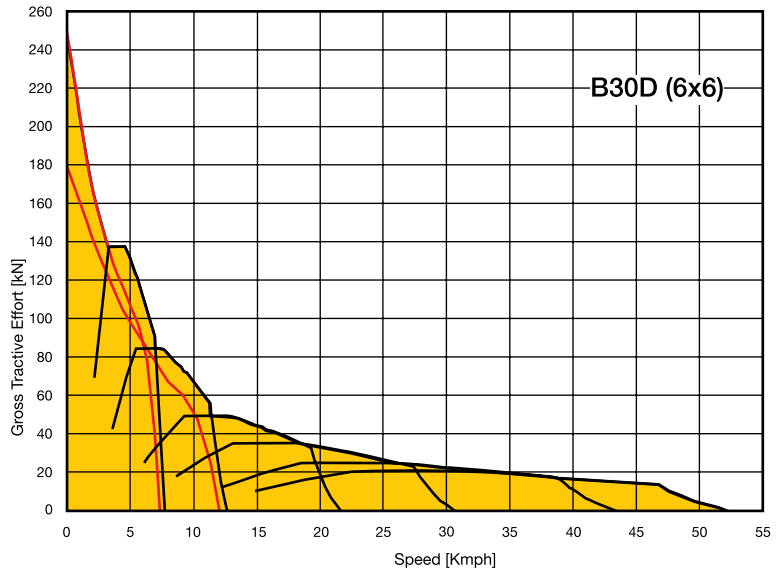
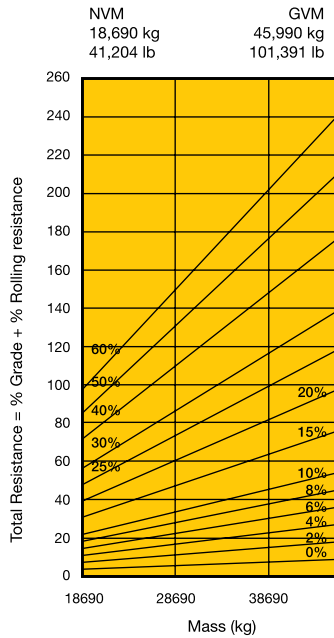

RETARDATION

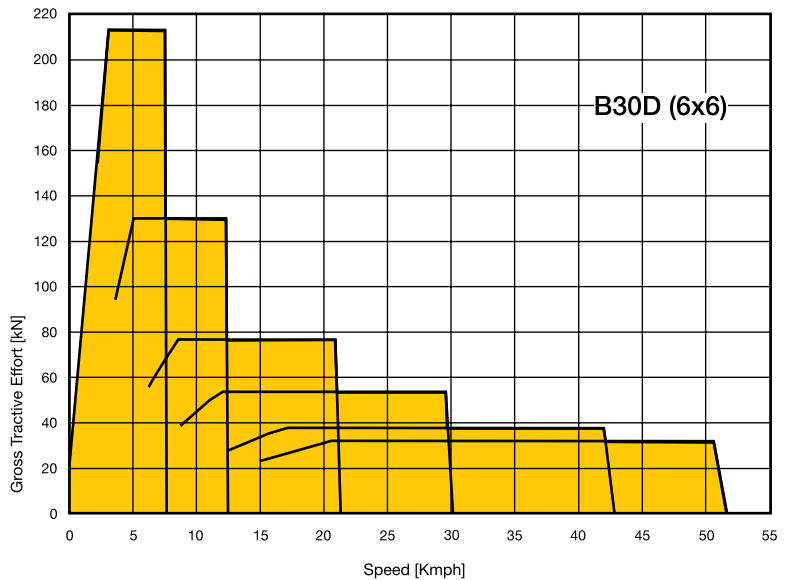
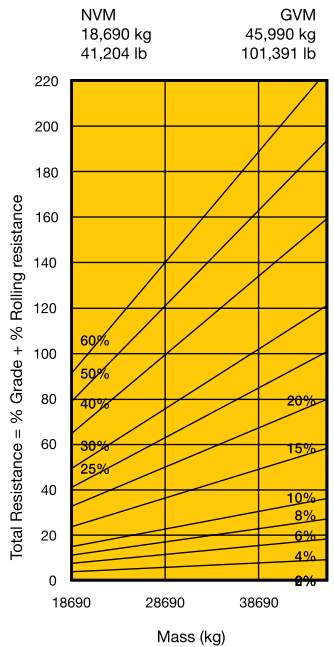

B30D 6x6 ARTICULATED DUMP TRUCK MKVI

DIMENSIONS

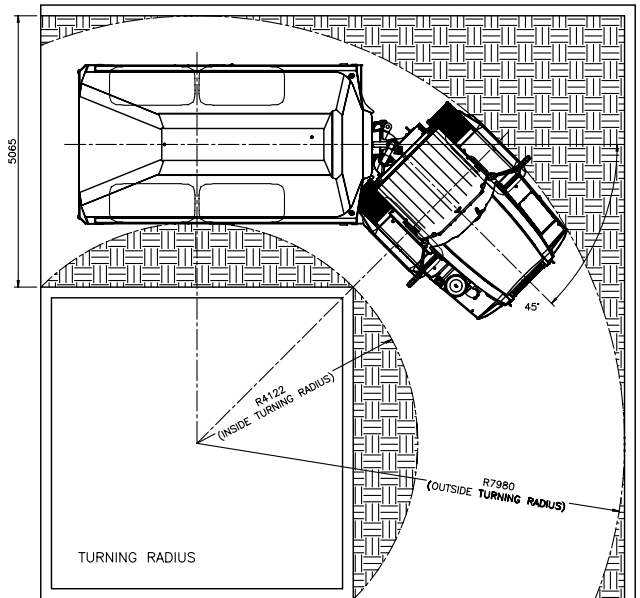
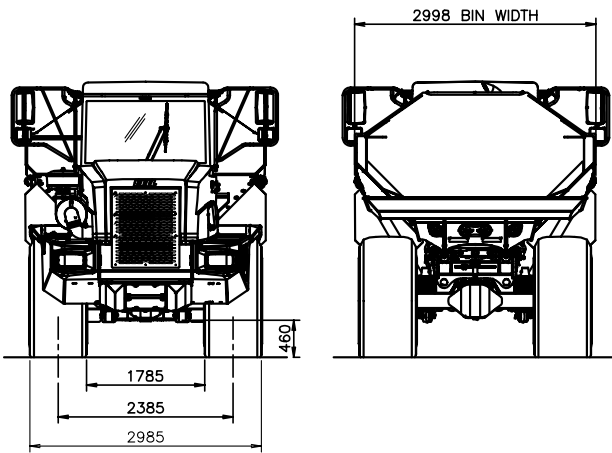
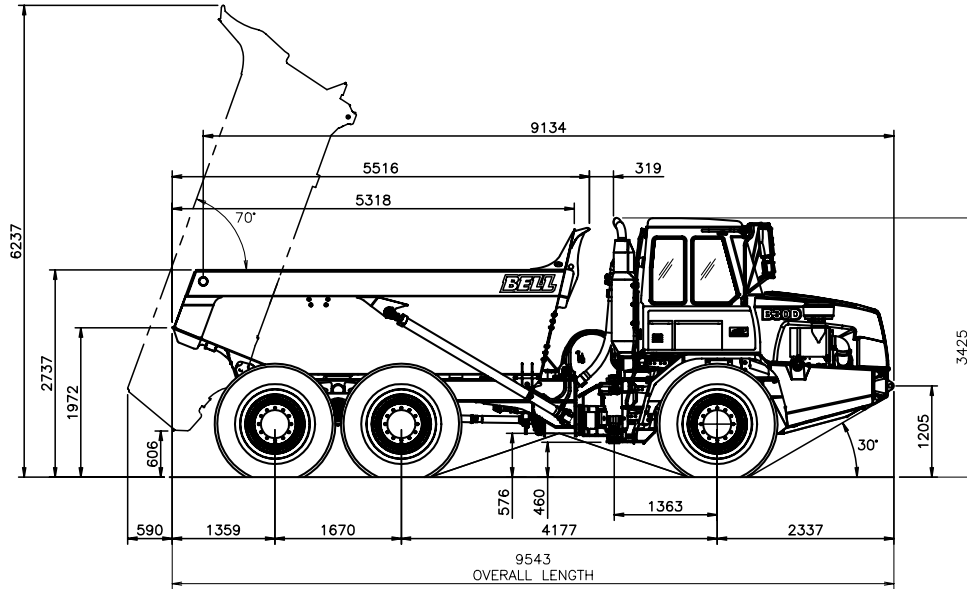

B30D 6x6 ARTICULATED DUMP TRUCK MKVI

AVAILABLE EQUIPMENT*

Cab

- ROPS/FOPS certification
- Protective rear window guard
- Tilt cab for service access
- Gas strut supported door
- Tinted safety glass
- Sliding windows
- Rear view mirrors- regular and wide angle
- Electrically adjustable rearview mirrors - one per side
- Sun visor
- Wiper/washer with intermittent control
- Tilt and telescoping steering wheel
- Adjustable, air suspension seat with retractable seat belt
- Fold-away trainer seat with retractable seat belt
- HVAC climate control system with filtered and ducted air
- Rotating beacon
- 12 V power outlet/12 V cigarette lighter
- Ash tray
- Drinks holder
- Cooled/heated lunch box
- I-Tip programmable bin tip
- Sound insulated to 76 dB(A) to ISO 6396
- Radio/CD/Tape
- Memory Module
- Air horn

MDU Features

- Operator / Site selected speed control
- Tipping counter
- Trip timer
- Trip distance
- On Board Weigh System (OBW)
- Transmission gear selection
- Fuel Consumption
- Diagnostics
- Intermittent wiper timing control
- Speedo calibration for alternative tyre sizes
- Metric /Imperial unit selection
- Warning lights with audible buzzer

Gauges

- Engine coolant temperature
- Engine oil pressure
- Transmission oil temperature
- Fuel
- Tachometer
- Battery voltage
- Hourmeter
- Odometer
- System air pressure

Vehicle

- Ground driven emergency steering
- Bin safety prop
- Articulation lock
- Integral transmission output retarder with 6 settings

Other

- (Factory or field installed)
- Groeneveld auto greasing system
 - Retractable sun visor
 - Exhaust body heating
 - Autogate
 - Body liners
 - Fleetmatic Satellite Monitoring System
 - Driver ID and immobiliser
 - Forward working lights
 - Artic reverse light
 - Fuel heater
 - External windshield visor
 - Headlight protection grills
 - Rear window wiper
 - Antenna mounting bracket
 - System for reverse camera
 - Wiggins quick fuelling system
 - Tyre pressure monitoring



*standard specification for machines may vary according to region

What makes the B30D a great performer...

- **With a highly efficient power and drivetrain combined with low rolling resistance, The Bell B30D delivers superior fuel efficiency**
- **High performance engine with increased power and torque and long service intervals**
- **Powerful hydraulic transmission retarder drastically cuts brake use, extending pad life up to a factor of five**
- **Fewer scheduled service requirements**
- **Supreme driver comfort from a nitrogen over oil strut independent suspension system**
- **Deluxe cab - setting new standards in comfort, sound levels and simplicity in operation**
- **Tight turning circle**
- **Electronic component protection**
- **Easy service access**
- **Fast tip cycles**
- **Low ground pressure to work jobs other trucks can't**

BELL INTERNATIONAL: Tel: +27 (0) 35-907 9431



Tel: +33 (0) 5 55 89 23 56



Tel: +49 (0) 6631 / 91 13 - 0



Tel: +34 91 879 60 19



Tel: +27 (0) 11-928-9700



Tel: +44 (0) 1283 712862



Tel: +7 495 771 20 27

E-mail: sales@bellequipment.com

• www.bellequipment.com

All dimensions are shown in millimetres, unless otherwise stated between brackets.
Under our policy of continuous improvement, we reserve the right to change specifications and design without prior notice. Photographs featured in this brochure may include optional equipment.

**Strong Reliable Machines
Strong Reliable Support**

BELL