



\*Actual mirrors differ to those shown\*

## MAIN SPECIFICATIONS

Model	NPR450M	NPR450M AMT	NPR450L	NPR450L AMT
Code	NP117	NP118	NP119	NP120
Configuration	4 x 2			
Gross Vehicle Mass	7,500 Kg			
Gross Combination Mass	11,000Kg			
Maximum towed mass braked	3,500 Kg			
Maximum towed mass unbraked	750 Kg			
Gradeability at GVM/GCM (1st gear)	29/18%			
Est. Engine RPM @ 90 Km/h	2060			
Turning circle kerb to kerb (m)	12.4		15.3	

## DRIVELINE SPECIFICATIONS

Engine Model	4HK1-TCN			
Type	4 cylinder 16 valve, gear driven SOHC. Euro IV exhaust emission compliant			
Displacement (cc)	5,193			
Compression ratio	17.5:1			
Max power (DIN Nett)	114kW 155PS (JIS Gross 118kW, 160PS) @ 2600 RPM			
Max torque (DIN Nett)	419N.m (JIS Gross 434N.m) @ 1,600 – 2,600 RPM			
Transmission model	MYY6S			
Forward gears	6			

## KERB MASS\* (kg)

Front	1,760	1,800	1,800	1,840
Rear	890	910	910	930
Total	2,650	2,710	2,710	2,770

\* Cab chassis as supplied from the factory and including 10 L of fuel

## DIMENSIONS (mm)

WB: Wheelbase	3,365	4,175
OAL: Overall length	5,985	7,338
EA: Rear of engine to rear axis	2,680	3,490
CE: Cab to rear of frame	4,302	5,655
ROH: Rear overhang	1,510	2053
RT: Rear track	1,650	
ORT: Overall rear tyres	2,115	
FW: Frame width @ Rear	850	
RFH: Frame height at rear axis	795	
BOC: Back of Cab Clearance	112	

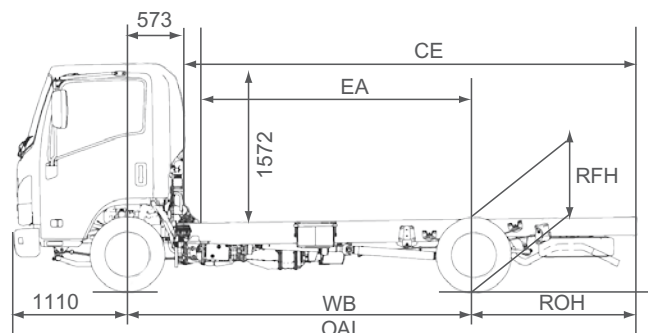
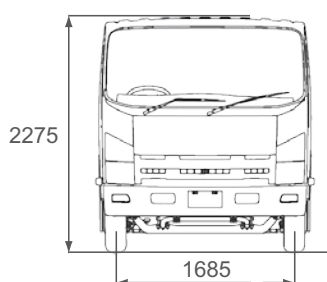
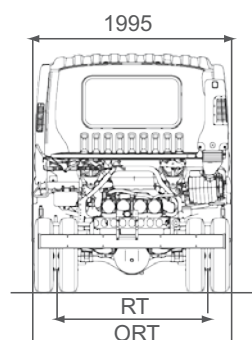

## Drive Line Specifications

### Engine-ISUZU 4HK1--TCN

- Bore x Stroke 115mm x 125mm

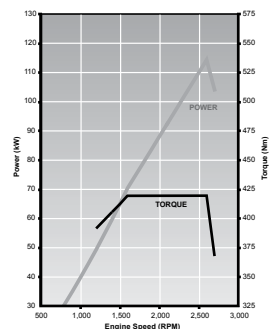

### Emission control system

- Euro IV with cooled Exhaust Gas recirculation and Diesel Particulate Diffuser (DPD)

### Lubrication

- Spin on element oil filter
- Plate type oil cooler
- System capacity approx 13 litres

### Cooling system

- Temperature controlled viscous fan hub
- Approx coolant capacity 18 litres

### Fuel System

- Electronically controlled, direct injection high pressure common rail
- Water in fuel sensor
- Lockable fuel cap
- Steel fuel tank capacity 140 litres

### Air Intake System

- Electronically controlled variable nozzle turbo charger with Air to Air Intercooler
- Rear of cab vertical air intake

### Clutch (manual models)

- Auto adjusting hydraulic control with vacuum assistance.
- Single plate 325mm diameter
- Total lining area 966 cm<sup>2</sup>

### AMT

- Fully automated hydraulically controlled wet clutch and fluid coupling with lock up and oil to air cooler
- Approx system capacity 6.6 litres

### Transmission: MYY6S Manual models

- 6 speed manual syncromesh on gears 1 through 6
- PTO provision on LHS of the transmission case countershaft driven.
- Approx oil capacity 3.5 litres

### Ratios :1

- 1st 5.979, 2nd 3.434, 3rd 1.862, 4th 1.297
- 5th 1.00, 6th .750, Rev 5.701

### Transmission MYY6S AMT models

- 6 speed Automated Manual Transmission with both fully automatic and sequential shift manual modes
- PTO provision on LHS of the transmission case countershaft driven.
- Approx oil capacity 3.5 litres

### Ratios :1

- 1st 5.979, 2nd 3.434, 3rd 1.862, 4th 1.297
- 5th 1.00, 6th .750, Rev 5.701

### Front Axle: ISUZU F031

- Reverse Elliot I beam
- Capacity 3,100Kg

### Rear Axle: ISUZU R066

- Full floating Banjo type
- Capacity 6,600Kg
- 320mm diameter ring gear
- Approx oil capacity 4.3 litres
- Ratio; 4.30:1

### Load limit Kg (on ground)

Front	Rear
3,100	6,400

## Chassis Specification

### Front Suspension

- Single stage, alloy steel, multi leaf spring 1300x70x11-4, 10-2, constant 163 N/mm
- Stabiliser bar
- Double acting hydraulic Shock absorbers

### Rear Suspension

- MLS main, MLS helper  
Main 1300x70x11-4, 12-2, constant 205N/mm  
Helper 850x70x9-7 combined 688N/mm
- Stabiliser bar
- Double acting hydraulic shock absorbers

### Steering

- Power assisted recirculating ball
- Gear ratio 20.9:1
- Turns lock to lock 5.4

### Brakes

- Auto adjusting front disc and rear drum brakes with dual circuit hydraulic control, hydraulic pressure assistance and Electronic Brake Distribution
- ABS and ASR (traction control)
- Hill Start Aid - except AMT
- Front discs 310mm x 42mm, ventilated
- Rear drum 320mm x 120mm
- 190mm diameter drum rear of transmission mounted park brake
- Vacuum controlled exhaust brake

### Chassis Frame

- Cold rivetted ladder frame. SAPH440 weldable steel parallel side members
- Frame side rail dimensions(mm) 216x70x6

- *Please refer to the Isuzu Body Builders guide for chassis modifications and body fitment*

### Wheels and Tyres

- 17.5x6x127mm six stud steel wheels
- 215/75R17.5 126/124M tubeless tyres
- Wheels painted silver
- Frame mounted spare wheel and tyre

### Electrical System

- 24 volt negative earth system
- Alternator 50 amp
- Battery 2 x 80D26L, 582CCA @-18c

## Cabin Specifications

### Cab Exterior

- All steel construction, high tensile steel used for cab underframe and door side impact beam reinforcement.
- Manual cab tilt to 45° with torsion bar assistance
- Liquid filled front and rear cab mounts
- Heavy duty non slip cab entry steps
- 70° opening doors
- Cab mounted front of cab main mirrors
- Polycarbonate bumper with steel backing frame
- Halogen multi reflector headlamps incorporating turn signal, additional door mounted side indicator lamps
- Roof mounted end position lamps
- Combination brake, turn, reverse and marker lamps, registration plate lamps, extended wiring harness, reverse alarm

### Cab Interior

- Contoured adjustable driver's bucket seat
- Passenger front bench seat with 2 seat capacity
- 3 point ELR seatbelts in all outboard seating positions, drivers seatbelt fitted with pretensioner

### Warranty

Vehicle: 36 months/100,000kms\*  
 Corrosion (Perforation): 36 months  
 \* Which ever occurs first. Subject to the terms & conditions detailed in the Owners manual Service and Supplement

- Lap belt in centre seating position
- Driver side SRS including air bag
- Door and roof pillar entry assist grips
- Lined cab interior, padded roof lining and vinyl floor coverings
- LH and RH overhead storage shelf
- Height/reach adjustable steering column, soft feel urethane steering wheel
- Electric windows
- Central locking with remote keyless entry and engine immobiliser
- Twin cup holders, 24v cigarette lighter.
- Door mounted storage pockets
- LH side glove box
- Interior light
- Intergrated air conditioning with 4 speed fan
- Radio/single disc CD with 2 speakers and auxillary input jack port
- 5 DIN sized compartments for storage or additional communication units

### Instrument & Controls

- Speedometer with digital odometer and two

Please refer to the Owners and Drivers Manual for more detailed operation, driving instructions and warnings

A policy of continual improvement means that the specifications are subject to change without notice. Contact your Isuzu dealer to confirm specifications

- tripmeters
- Tachometer, engine coolant temperature and fuel level gauges
- Two speed wipers with intermittent wipe mode
- Key operated engine start/stop and steering lock
- HSA slow/fast engagement control and on/off switch - except AMT
- ASR on/off switch
- DPD manual regeneration switch
- Cruise control - AMT only
- Multi display - AMT only
- AMT: slow/fast clutch re-engagement control, 1st gear selection, economy mode
- LH combination stalk: windscreen wipers, washers and exhaust brake
- RH combination stalk: turn signals and headlamps cruise control - AMT only
- Warning lamps: check eng, oil pressure, ABS, SRS alternator charge, service brakes, park brake, water in fuel, seat belt unbuckled, check AMT - AMT only
- Indicator lamps: HSA-except AMT, warm up system, high beam, ASR, DPD status, exhaust brake, turn signals
- AMT: econo mode, 1st gear start, gear selection display
- Multi display: (AMT only) shows service interval, instantaneous and average fuel consumption, DPD bar chart, hourmeter, voltmeter, time/day/date and 40 - 120km/h adjustable vehicle speed warning