

IR Montabert

Silver Clip 12

Breaker suspended
in housing

No tie rods

Easy & Fast
breaker disassembly

Easy & fast tool removal
Large Tool Ø



Sealed energy chamber
with diaphragm

AUTOPOWER
Automatic pressure regulator

Optimum size

Lubricating system
protected by the clip

**For carriers from
1.2t up to 2.0t**





Montabert

**Silver
Clip 12**

Optional attachments to the Silver Clip

CLIP BUCKET



- Debris removal
- Easy & fast installation
- No hydraulic connections
- Saves time & money

CLIP RAM



- High efficiency compactor
- Easy & fast installation
- No hydraulic connections
- Saves time & money



Montabert

Silver Clip 12



Adaptability

Wide flow range & back pressure

General size : width high & low

High performances and no overheating

Soundproof breaker & isolated :

Less noise & Less vibration

Reliability

Few components

Sealed energy chamber with diaphragm

Dust protection

No tie rods

Reinforced housing

Breaker suspended in housing

Lubricating system protected by the clip



Performances

high production

High energy

Large Tool diameter

Maintenance

Easy & fast : Breaker disassembly

Sliding bushing

Inflation system

Tool removal

Maneuverability

Size & overall dimensions

Specifications

Carrier weight	min. t	1,2
	max t.	2
Operating weight	kg	120
Height with tool	mm	1118
Tool diameter	mm	45
Blow frequency	min. bl/min	750
	max. bl/min	1600
Oil flow	min. l/min	20
	max. l/min	35
Operating pressure	bar	120
Acceptable back pressure	bar	32

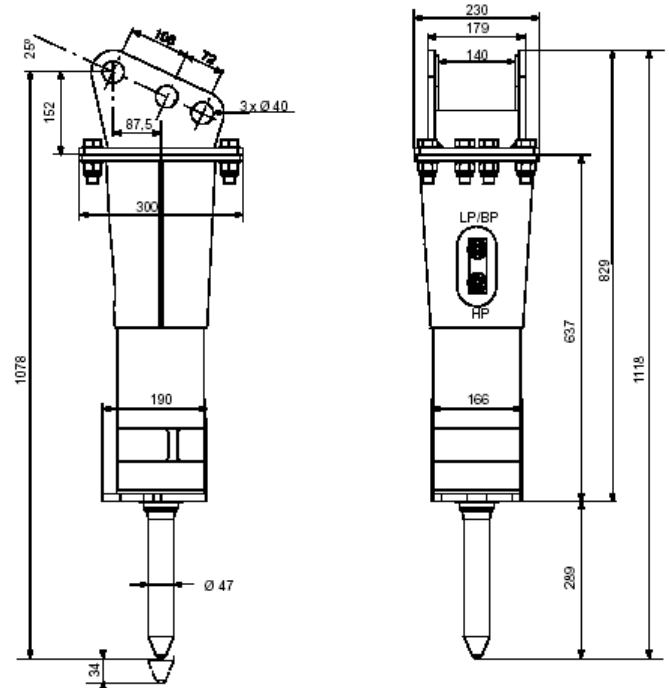

CB 12-35*

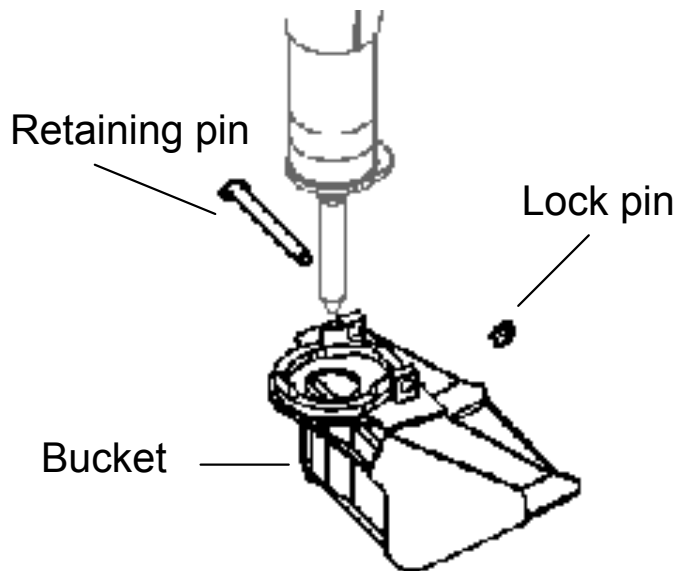

Weight (kg)	28
Volume (l)	25
Width (mm)	352
Height (mm)	434

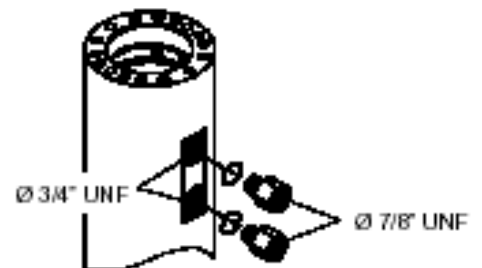
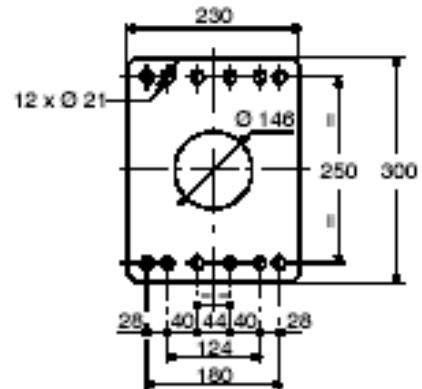

* Min. weight adaptation >1.5t