

ZAXIS-3 series Zero tail swing version

HITACHI

ZAXIS
35U
F Type



HYDRAULIC EXCAVATOR

- Model Code : ZX35U-3F
- Engine Rated Power : 21.3 kW (28.5 HP)
- Operating Weight : 3 520 - 3 780 kg
- Backhoe Bucket : 0.11 m³

Compact Yet Productive. Dependable Partner at Confined Work Place

The edge in hydraulic technology makes operation more smooth and productive.



Compact Body with Short Rear End
The compact short rear end design allows efficient operation even in confined spaces.

Notes : Some of the pictures in this brochure show an unmanned machine with attachments in an operating position. These were taken for demonstration purposes only and the actions shown are not recommended under normal operating conditions. Some of this brochure photos shown may include optional equipment.

Wealth of convenient design features

Clean and Powerful



Powerful 3-Cylinder Engine with Ample Displacement

High dependability and availability are achieved behind the new-generation engine for high production and environmentally responsible operation.

- The new engine complies with the Emission Regulations EU Stage III A



The machine pictured above includes optional equipments.

Quiet, Fuel-Efficient Operation

High Fuel Efficiency (Eco Zone)

The machine can get the job done with less fuel and more production. Optimal control of engine speed and torque as well as hydraulic pressure achieves high fuel efficiency and production. The new setting of the Eco Zone boosts fuel economy and operating efficiency.

Smooth Combined Operations

The proven 3-pump hydraulic system and arm regenerative circuit are further improved for more efficient simultaneous operations, including digging, leveling and wall cutting.

Hydraulic Pilot Control Levers

Hydraulic pilot operation levers provide smooth control and easy operation.



Automatic Travel Speed Control at High Speed

During high-speed travel, when the load is increased for steering for example, travel speed is lowered automatically and smoothly. When the load is decreased, travel speed is resumed accordingly.

Auto-Idle Saves Fuel Consumption

When shifting the control lever to neutral, engine speed slows automatically down to idling speed four seconds later, reducing fuel consumption, emissions and noise. This feature is advantageous when working in urban residential districts requiring special environmental awareness.



Additional Counterweight (Optional)

When using a heavy front attachment such as a fork grapple, the additional counterweight is easily mounted for higher stability.

- Additional counterweight: 230 kg

A Solid Base for a Long Life

Reinforced Front Attachment

The front attachment is redesigned for higher strength and reliability. The boom top is strengthened for less jerking due to wear.



WC* Thermal Spraying

WC thermal spraying is done at contact surfaces between arm top and bucket to reduce wear and jerking.

*Tungsten Carbide

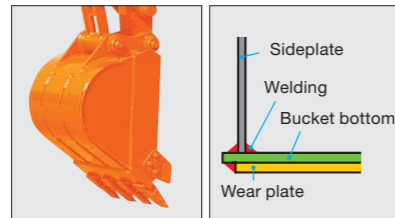

Durable Flat-Bottom Bucket

The flat-bottom bucket is provided standard to minimize bucket bottom wear. Wide wear plates are welded to the bucket bottom for increased durability.



Single Swing Pin

A single large swing pin is used to eliminate jerking.



Reinforced Boom Top

The boom top bracket, using high-tensile steel, reduces boss wear and jerking.



Job-Proven HN Bushings

The field-proven HN bushing, a Hitachi original, is utilized at each front pin joint to reduce jerking and servicing. Lubricating interval is a long 500 hours.

Reinforced Undercarriage

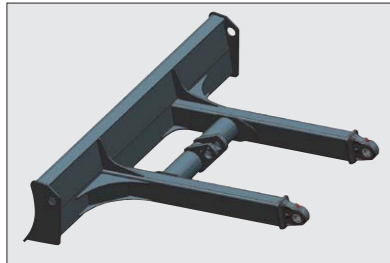

Reinforced Blade

The box-section stay is utilized at the blade for higher durability.

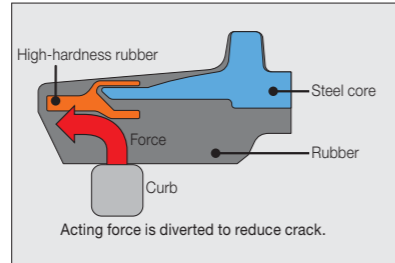

New-Structure Rubber Crawlers

The Hitachi-developed rubber crawlers are highly durable, featuring a steel-cored structure that protects shoe edges from being damaged even when riding on curbs.

Reinforced Upperstructure

Enlarged Counterweight and Weighted Undercarriage

The box-section frame is adopted, combining low weight and high durability. The enlarged counterweight and weighted undercarriage help lower the center of gravity and increase stability.

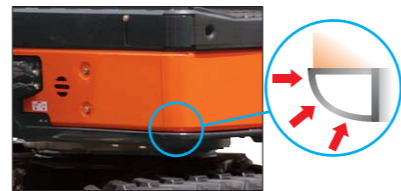
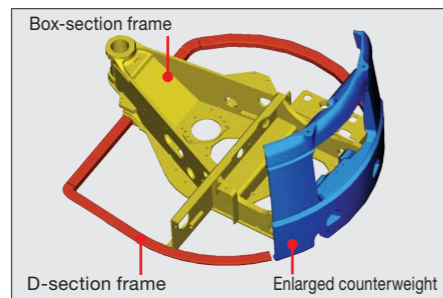

Reinforced D-Shaped Frame

The machine frame is reinforced with a D-shaped frame that protects against damage and impact by obstructions.

A New Standard in Operator Comfort

Largest-in-Class Cab Space

The cab space, conforming to the European standards, is the largest among the mini excavators for pleasant, efficient operation.

Short-Stroke Levers

Fingertip-control, short-stroke levers are utilized for long, continuous operation with less fatigue.

Bright Cab Interior Coloring

A new color scheme is adopted to the cab interior and controls for pleasant operation.



High Backrest (Cab)

The high Backrest is utilized to hold the operator comfortably for long-hours operation. Backrest is increased in height, and formed to hold the operator well.

Pictured is a cab specification.



Shown is a cab specification, including options such as multi-function levers.



Rubber Mounted Floor

The cab rests on 4 shock-absorbing rubber mounts to ensure comfortable operation.



Improved Visibility with Roof Visor (Canopy)

Miscellaneous Devices



Canopy Cab
Seat backrest box Drink holder



Air conditioner / AM-FM radio (Cab)
Tool box (canopy)

Wealth of Convenient Design Features



Conveniently Located Servicing Points



Simplified Daily Maintenance

The engine cover can slide up and down for quick servicing even in confined space. No more swing-open cover that obstructs maintenance and servicing jobs.

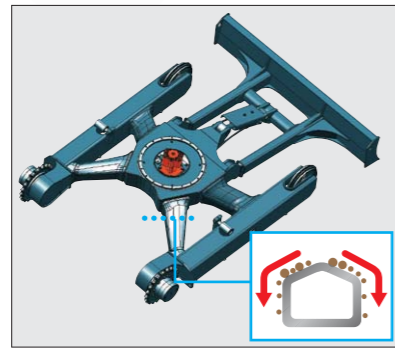

Uses Tracks Promoting Easy Mud Removal

The X-beam track frame is smooth for mud removal. This shortens machine washing time and reduces disposal costs, too.



Easy to Repair Steel Cover

A steel cover is utilized for tough operation, allowing easy repair if damaged. The steel cover is durable, recyclable and economical.



Finned Radiator and Oil Cooler for Effective Cooling

The radiator and oil cooler, made of rust-resistant aluminum, are integrated with wavy fins for effective cooling. Fins are easy to clean and hard to be packed with dirt.



The full-open cover provides direct access to exposed devices inside for easy maintenance. The cab can be tilted up for easy inspection and servicing. (In daily maintenance, there is no need for cab tilting-up.) Split hydraulic hoses are used for quick replacement.

**When using the floor tilt mechanism, consult your nearest Hitachi dealer. If bolts are removed or installed by unauthorized personnel, non-conformity to ROPS may occur.*



Easy-to-Maintain Grease Bath Type Swing Gear

The grease bath type swing gear extends lubricating intervals up to 500 hours for easy maintenance.

Hydraulic Oil Circulation Type Swing Reduction Gear

The swing reduction gear is a hydraulic oil circulation type that does not need cumbersome gear oil change. Long-life hydraulic oil extends replacement interval up to 2000 hours.

Comprehensive Safety Features

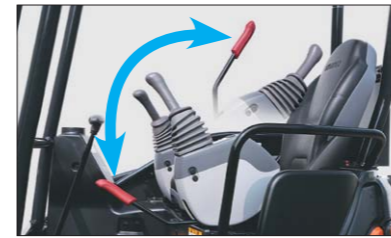

Pilot-Control Shut-Off Lever

All operations-front, swing, travel and blade-can be shut off by locking the pilot control shut-off valve. This effectively prevents accidental lever control.

Neutral Engine Start System

The engine can start only when the pilot control shut-off lever is locked. This is called the neutral engine start system. This eliminates unexpected lurching when the engine suddenly starts when touching the control lever unconsciously.

Swing/Travel Parking Brakes (Standard)

The swing parking brake and travel parking brake are both provided standard for enhanced safety.



Illustrated is ROPS/OPG cab (with top guard).

ROPS/TOPS Cab and Canopy

Both canopy and cab conform to the latest ROPS (ISO 3471), TOPS (ISO 12117), and OPG (level 1) standards. The seat belt protects the operator as well. The operator's cab and canopy, complying with the international standards, are mounted to protect the operator in the case of tipping.



*ROPS (Roll-Over Protection Structure) for protection of the operator held by seat belt in the case of rolling-over
TOPS (Tip-Over Protection Structure) for operator protection in the case of tipping-over
OPG (Operator Protective Guards) for operator protection against falling objects*

Additional Features



Retractable seat belt Rearview mirror (Cab)



Anti-slip plate Wrist rest

A Recyclable Machine

All resin parts are marked to facilitate recycling. The machine is completely leadfree. The radiator and oil cooler are made from aluminium and all wires are leadless. In addition, biodegradable hydraulic oil is available for jobsites where special environmental care is required.



Suitable for a Variety of Applications (Optional)



Pad crawler shoes



Theft deterrent system

SPECIFICATIONS

ENGINE

Model.....	Yanmar 3TNV88
Type.....	4-cycle water-cooled, direct injection
No. of cylinders	3
Rated power	
ISO 9249, net.....	21.3 kW (28.5 HP) at 2 400 min ⁻¹ (rpm)
EEC 80/1269, net...	21.3 kW (28.5 HP) at 2 400 min ⁻¹ (rpm)
SAE J1349, net	21.3 kW (28.5 HP) at 2 400 min ⁻¹ (rpm)
DIN 6271, net.....	21.2 kW (28.4 HP) at 2 400 min ⁻¹ (rpm)
Gross	22 kW (29.5 HP) at 2 400 min ⁻¹ (rpm)
Maximum torque.....	106 Nm (10.8 kgf m) at 1 000 min ⁻¹ (rpm)
Piston displacement...	1.642 L
Bore and stroke	88 mm x 90 mm
Electric system	
Voltage.....	12 V
Batteries	55 Ah
Alternator.....	55 A
Starter motor.....	2.3 kW

HYDRAULIC SYSTEM

Main pumps	2 variable displacement axial piston pumps 1 gear pump
Maximum oil flow...	2 x 38.4 L/min 1 x 25.2 L/min
Pilot pump.....	1 gear pump
Maximum oil flow...	10.8 L/min

Hydraulic Motors

Travel	2 variable displacement axial piston motors
Swing	1 axial piston motor
Auxiliary	
Maximum oil flow...	63.6 L/min

Relief Valve Settings

Implement circuit	24.5 MPa (250 kgf/cm ²)
Swing circuit.....	16.7 MPa (150 kgf/cm ²)
Travel circuit	24.5 MPa (250 kgf/cm ²)
Pilot circuit.....	3.9 MPa (40 kgf/cm ²)
Auxiliary circuit.....	24.5 MPa (250 kgf/cm ²)

Hydraulic Cylinders

High-strength piston rods and tubes. Cylinder cushion mechanisms provided in boom and arm cylinder to absorb shock at stroke ends.

Dimensions

	Quantity	Bore	Rod diameter	Stroke
Boom	1	85 mm	50 mm	576 mm
Arm	1	75 mm	45 mm	597 mm
Bucket	1	65 mm	40 mm	435 mm
Blade	1	95 mm	45 mm	140 mm
Boom swing	1	85 mm	45 mm	525 mm

Hydraulic Filters

Hydraulic circuits use high-quality hydraulic filters. A suction filter is incorporated in the suction line, and full-flow filters in the return line.

CONTROLS

Hydraulic pilot controls levers for all operations.

Implement levers	2
Travel levers with pedals.....	2
Blade lever.....	1

UPPERSTRUCTURE

Revolving Frame

Welded sturdy box construction, using heavy-gauge steel plates for ruggedness. D-section frame for resistance to deformation.

Swing Device

Axial piston motor with planetary reduction gear is lubricated by hydraulic oil. Swing circle is single-row, shear-type ball bearing with induction-hardened internal gear. Internal gear and pinion gear are immersed in lubricant. Swing parking brake is spring-set/hydraulic-released disc type.

Swing speed	9.0 min ⁻¹ (rpm)
Swing torque.....	5.47 kN·m (558 kgf·m)

Operator's Cab

Independent spacious cab, 960 mm wide by 1 520 mm high, conforming to ISO* Standards. Reinforced glass windows on 4 sides for visibility.

Front windows (upper and lower) can be opened. Reclining seat.

* International Standardization Organization

UNDERCARRIAGE

Tracks

Tractor-type undercarriage. Welded track frame using selected materials. Side frame welded to track frame.

Numbers of Rollers and Shoes on Each Side

Upper rollers.....	1
Lower rollers.....	4

Travel Device

Each track driven by 2-speed axial piston motor through planetary reduction gear for counterrotation of the tracks. Sprockets are replaceable.

Parking brake is spring-set/hydraulic-released disc type.

Travel speeds	High : 0 to 4.4 km/h Low : 0 to 2.9 km/h
---------------------	---

Maximum traction force.. 27 kN (2 750 kgf)

Gradeability

58 % (30 degree) continuous

WEIGHTS AND GROUND PRESSURE

Equipped with 2.47 m boom, 1.32 m arm and 0.11 m³ bucket (ISO heaped) rubber shoes 300 mm.

Cab type	Operating weight	Ground pressure
4-Pillars canopy	3 520 kg	32 kPa (0.32 kgf/cm ²)
Cab	3 690 kg	33 kPa (0.34 kgf/cm ²)

* (Operating weight with 0.11 m³ bucket if fully serviced +80 kg operator ISO 6016).

SERVICE REFILL CAPACITIES

Fuel tank	40.0 L
Engine coolant	5.0 L
Engine oil	7.2 L
Travel device (each side)	0.6 L
Hydraulic system	56.0 L
Hydraulic oil tank	32.0 L

BACKHOE ATTACHMENTS

Boom and arms are of welded, box-section design. 2.47 m boom, 1.32 m and 1.72 m arms are available.

Buckets

Capacity ISO heaped	Width without side cutters	Weight
0.04 m ³	250 mm	55 kg
0.055 m ³	300 mm	60 kg
0.065 m ³	350 mm	65 kg
0.08 m ³	400 mm	67 kg
0.09 m ³	450 mm	73 kg
0.10 m ³	500 mm	76 kg
0.11 m ³	550 mm	80 kg
0.13 m ³	600 mm	84 kg

SPECIFICATIONS

DIMENSIONS

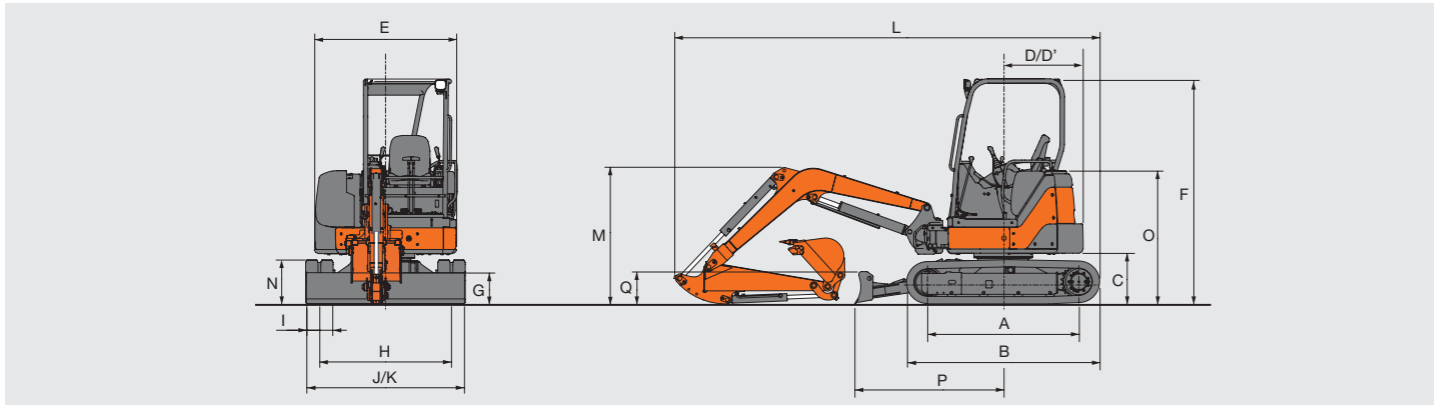

Unit : mm

Model code	ZX35U-3F			
	1.32 m arm		1.72 m arm	
	Canopy	Cab	Canopy	Cab
A Distance between tumbler	1 650 (1 660)		1 650 (1 660)	
B Undercarriage length	2 100 (2 120)		2 100 (2 120)	
* C Counterweight clearance	550 (540)		550 (540)	
D Rear-end swing radius	870		870	
D' Rear-end length	870		870	
E Overall width of upperstructure	1 550		1 550	
F Overall height	2 460 (2 450)	2 500 (2 490)	2 460 (2 450)	2 500 (2 490)
* G Min. ground clearance	280 (270)		280 (270)	
H Track gauge	1 440		1 440	
I Track shoe width	300		300	
J Undercarriage width	1 740		1 740	
K Overall width	1 740		1 740	
L Overall length	4 650		4 780	
M Overall height of boom	1 490		1 910	
N Track height	480 (470)		480 (470)	
O Engine cover height	1 420 (1 410)		1 420 (1 410)	
P Horizontal distance to blade	1 610		1 610	
Q Blade height	355		355	

Data in () are dimensions of grouser shoe.

This illustration shows the ZX35U-3F equipment with 1.32 m arm, 0.11 m³ bucket and 300 mm rubber shoes

WORKING RANGES

Unit: mm

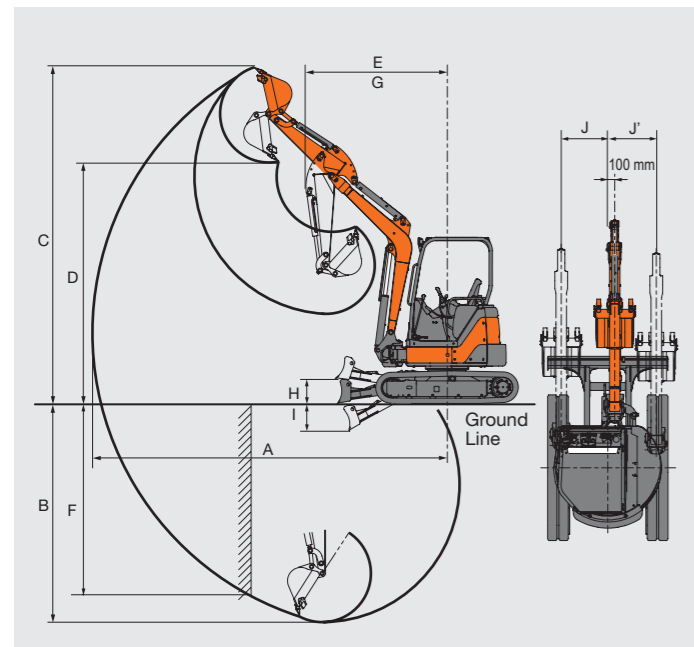

Model code	ZX35U-3F			
	1.32 m arm		1.72 m arm	
	Canopy	Cab	Canopy	Cab
A Max. digging reach	5 210		5 520	
B Max. digging depth	5 080		3 450	
C Max. cutting height	4 870	4 710	4 950	4 760
D Max. dumping height	3 470	3 320	3 570	3 390
E Min. swing radius	2 070	2 230	2 170	2 300
F Max. vertical wall	2 590		2 800	
G Working radius at Min. swing radius (Max. boom-swing angle)	1 670	1 810	1 730	1 970
H Blade bottom highest position above ground	370			
I Blade bottom lowest position above ground	390			
J/J' Offset distance (Max. boom-swing angle)	605 / 740	605 / 700	605 / 740	605 / 700
Bucket digging force ISO : PCSA kN (kgf)	27.5 (2 800)		27.5 (2 800)	
Bucket digging force SAE kN (kgf)	23.0 (2 350)		23.0 (2 350)	
Arm crowd force ISO : PCSA kN (kgf)	19.1 (1 950)		17.2 (1 750)	
Arm crowd force SAE kN (kgf)	17.9 (1 830)		16.1 (1 640)	

This illustration shows the ZX35U-3F equipment with 1.32 m arm, 0.11 m³ bucket and 300 mm rubber shoes

LIFTING CAPACITIES

Notes: 1. Ratings are based on SAE J1097.

2. Lifting capacity of the ZAXIS Series does not exceed 75% of tipping load with the machine on firm, level ground or 87% full hydraulic capacity.

3. The load point is a hook (not standard equipment) located on the back of the bucket.

4. *Indicates load limited by hydraulic capacity.

5. 0 m = Ground.

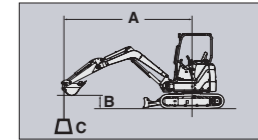

A: Load radius
B: Load point height
C: Lifting capacity

ZX35U-3F Canopy Version, Blade above Ground, 1.32 m Arm

Rating over-side or 360 degrees

Rating over-front

Unit: 1 000 kg

Conditions	Load point height	Load radius								At max. reach				
		1.0 m		2.0 m		3.0 m		4.0 m		meter				
Arm 1.32 m Rubber shoes 300 mm	3.0 m									0.48	0.49	0.38	0.39	4.58
	2.0 m					0.76	0.80	0.47	0.49	0.32	0.33	0.32	0.33	4.94
	1.0 m					0.70	0.74	0.45	0.47	0.31	0.32	0.31	0.32	5.00
	0 (Ground)					0.66	0.70	0.43	0.45	0.33	0.34	0.33	0.34	4.78
	-1.0 m	*1.58	*1.58	1.29	1.39	0.66	0.69	0.42	0.44	0.40	0.42	0.40	0.42	4.22
-2.0 m			1.32	1.42	0.68	0.71								

Conditions	Load point height	Load radius								At max. reach				
		1.0 m		2.0 m		3.0 m		4.0 m		meter				
Arm 1.32 m Rubber shoes 300 mm Additional counterweight 230 kg	3.0 m									0.56	0.59	0.45	0.47	4.58
	2.0 m					*0.86	*0.86	0.55	0.58	0.39	0.41	0.39	0.41	4.94
	1.0 m					0.83	0.87	0.53	0.56	0.37	0.39	0.37	0.39	5.00
	0 (Ground)					0.79	0.83	0.51	0.54	0.40	0.41	0.41	0.41	4.78
	-1.0 m	*1.58	*1.58	1.51	1.64	0.78	0.82	0.51	0.53	0.48	0.50	0.48	0.50	4.22
-2.0 m			1.55	1.67	0.80	0.84								

ZX35U-3F Canopy Version, Blade on Ground, 1.32 m Arm

Unit: 1 000 kg

Conditions	Load point height	Load radius								At max. reach				
		1.0 m		2.0 m		3.0 m		4.0 m		meter				
Arm 1.32 m Rubber shoes 300 mm	3.0 m									0.48	*0.71	0.38	*0.52	4.58
	2.0 m					0.76	*0.86	0.47	*0.77	0.32	*0.52	0.32	*0.52	4.94
	1.0 m					0.70	*1.29	0.45	*0.91	0.31	*0.55	0.31	*0.55	5.00
	0 (Ground)					0.66	*1.54	0.43	*1.02	0.33	*0.64	0.33	*0.64	4.78
	-1.0 m	*1.58	*1.58	1.29	*2.37	0.66	*1.49	0.42	*0.98	0.40	*0.81	0.40	*0.81	4.22
-2.0 m			1.32	*1.73	0.68	*1.10								

Conditions	Load point height	Load radius								At max. reach				
		1.0 m		2.0 m		3.0 m		4.0 m		meter				
Arm 1.32 m Rubber shoes 300 mm Additional counterweight 230 kg	3.0 m									0.56	*0.71	0.45	*0.52	4.58
	2.0 m					*0.86	*0.86	0.55	*0.77	0.39	*0.52	0.39	*0.52	4.94
	1.0 m					0.83	*1.29	0.53	*0.91	0.37	*0.55	0.37	*0.55	5.00
	0 (Ground)					0.79	*1.54	0.51	*1.02	0.40	*0.64	0.40	*0.64	4.78
	-1.0 m	*1.58	*1.58	1.51	*2.37	0.78	*1.49	0.51	*0.98	0.48	*0.81	0.48	*0.81	4.22
-2.0 m			1.55	*1.73	0.80	*1.10								

ZX35U-3F Canopy Version, Blade above Ground, 1.72 m Arm

Unit: 1 000 kg

Conditions	Load point height	Load radius										At max. reach								
		1.0 m		2.0 m		3.0 m		4.0 m		5.0 m		meter								
Arm 1.72 m Rubber shoes 300 mm	3.0 m											0.51	0.53	0.35	0.36	4.93				
	2.0 m											0.50	0.52	0.31	0.31	5.26				
	1.0 m											0.75	0.79	0.47	0.49	0.32	0.33	0.29	0.30	5.32
	0 (Ground)											0.70	0.73	0.45	0.47	0.30	0.31	0.30	0.31	5.12
	-1.0 m	*1.34	*1.34	1.32	1.42	0.68	0.71	0.44	0.45						0.36	0.37	0.36	0.37	4.61	
-2.0 m	*2.35	*2.35	1.35	1.45	0.69	0.72														

Conditions	Load point height	Load radius										At max. reach										
		1.0 m		2.0 m		3.0 m		4.0 m		5.0 m		meter										
Arm 1.72 m Rubber shoes 300 mm Additional counterweight 230 kg	3.0 m													0.42	0.43	4.93						
	2.0 m													0.37	0.38	5.26						
	1.0 m													0.88	0.92	0.56	0.58	0.39	0.40	0.35	0.36	5.32
	0 (Ground)													0.82	0.86	0.54	0.56			0.37	0.38	5.12
	-1.0 m	*1.34	*1.34	1.55	1.67	0.81	0.85	0.52	0.55											0.43	0.45	4.61
-2.0 m	*2.35	*2.35	1.57	1.69	0.81	0.85																

ZX35U-3F Canopy Version, Blade on Ground, 1.72 m Arm

Unit: 1 000 kg

Conditions	Load point height	Load radius										At max. reach									
		1.0 m		2.0 m		3.0 m		4.0 m		5.0 m		meter									
Arm 1.72 m Rubber shoes 300 mm	3.0 m											0.51	*0.57	0.35	*0.54	4.93					
	2.0 m											0.50	*0.65	0.31	*0.55	5.26					
	1.0 m											0.75	*1.10	0.47	*0.81	0.32	*0.71	0.29	*0.59	5.32	
	0 (Ground)											0.70	*1.46	0.45	*0.97			0.30	*0.68	5.12	
	-1.0 m	*1.34	*1.34	1.32	*2.18	0.68	0.71	0.44	*1.01						0.36	*0.77	0.36	*0.77	4.61		
-2.0 m	*2.35	*2.35	1.35	*2.18	0.69	*1.30															

Conditions	Load point height	Load radius										At max. reach										
		1.0 m		2.0 m		3.0 m		4.0 m		5.0 m		meter										
Arm 1.72 m Rubber shoes 300 mm Additional counterweight 230 kg	3.0 m													0.42	*0.54	4.93						
	2.0 m													0.59	*0.65	5.26						
	1.0 m													0.88	*1.10	0.56	*0.81	0.39	*0.71	0.35	*0.59	5.32
	0 (Ground)													0.82	*1.46	0.54	*0.97			0.37	*0.68	5.12
	-1.0 m	*1.34	*1.34	1.55	*2.18	0.81	*1.53	0.52	*1.01													

EQUIPMENT

STANDARD EQUIPMENT

Standard equipment may vary by country, so please consult your Hitachi dealer for details.

ENGINE

- Water-separator for engine fuel
- Radiator reserve tank
- Electrical fuel feed pump
- Cartridge-type engine oil filter
- Fuel filter

HYDRAULIC SYSTEM

- Hydraulic pilot type control levers
- Pilot control shut-off lever with neutral engine start system
- Swing parking brake
- Travel parking brake
- Two-speed travel system
- Auto idling system
- Suction filter
- Full-flow filter
- Pilot filter
- Boom anti-drift valve
- Valve for extra piping

4-PILLARS CANOPY

- ROPS/OPG canopy
- Reclining seat
- Suspension seat
- Retractable seat belt
- Wrist rests
- Drink holder
- Electric horn
- Cigarette lighter
- Floor mat

UPPERSTRUCTURE

- Tool box
- Rear view mirror

UNDERCARRIAGE

- 300 mm rubber shoes

FRONT ATTACHMENTS

- HN bushing
- 1.32 m arm
- Extra piping

OPTIONAL EQUIPMENT

Optional equipment may vary by country, so please consult your Hitachi dealer for details.

CAB

- ROPS/OPG cab
- Air conditioner
- AM/FM radio
- Window washer
- Defroster
- Reclining seat
- Suspension seat
- Retractable seat belt
- Wrist rests
- Spare power supply
- Wiper
- Drink holder
- Electric horn
- Cigarette lighter
- Floor mat

UPPERSTRUCTURE

- Accumulator
- Additional counterweight : 230 kg
- Ignition block system
- Multi-function lever (3 position switch type)
- Auxiliary overload relief valve

UNDERCARRIAGE

- 300 mm grouser shoes
- 300 mm pad crawler shoes

FRONT ATTACHMENTS

- 1.72 m arm
- Backhoe buckets (refer to specification page)

Prior to operating this machine, it may be necessary to make modifications to it so that it complies with the local regulatory standards (including safety standards) and legal requirements of that particular country. Please do not export or operate this machine outside of the country of its intended use until such compliance has been confirmed.

These specifications are subject to change without notice.

Illustrations and photos show the standard models, and may or may not include optional equipment, accessories, and all standard equipment with some differences in color and features.

Before use, read and understand the Operator's Manual for proper operation.