



# J3C COMPACT JAW CRUSHER

The J3C compact jaw crushers are the perfect solution for projects with small footprints but big requirements. These compact, mobile crushers are suited particularly to construction and demolition recycling, asphalt recycling, and aggregates.

## FEATURES

- ✓ Highly compact design for site-to-site and on-site mobility
- ✓ Powerful 890mm (35") x 500mm (20") Jaw Crusher
- ✓ Reverse crushing
- ✓ Able to track and crush simultaneously
- ✓ Various jaw die options
- ✓ Integrated hydraulic folding conveyors
- ✓ Open chassis design for ease of maintenance
- ✓ Efficient and simple operation



The versatile, mobile J3C crusher moves nimbly around in small spaces, and continues moving while crushing.

Formerly known as the J35, the J3C's small footprint is uniquely suited to the demolition and asphalt recycling, aggregates and smaller scale construction projects. Less than 2.5m wide, the crushers can be transported easily from site to site.

The new line boasts flexibility as well. Not only can the J3C continue crushing while moving, it can convert to a recirculating crusher in just a few hours.

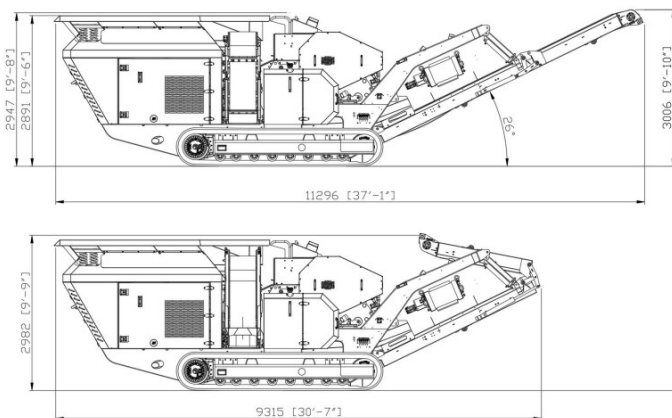

## J3 TECH SPECS

<b>Engine</b>	162 kW (218 Hp)
<b>Crushing Chamber</b> (W x D)	890mm (35") x 500mm (20")
<b>Stockpile Heights</b>	
Main Conveyor	3006mm (9' - 10")
Side Conveyor	2583mm (8' - 6")
<b>Grizzly Feeder</b>	
Width	800mm (31.5")
Length	3750mm (147.6")
<b>Hopper</b>	
Width	2000mm (78.7")
Length	4215mm (166")

## TRANSPORT

Transport Height	2.982m (9' 9")
Transport Length	9.315m (30' 7")
Transport Width	2.486m (9' 9")
Weight	23,700 kg (52,250 lbs)

## OPTIONS

Main Conveyor Variable Speed Control | Overband Magnet | Water Pump and Dust Suppression System | Various Jaw Die Pattern Options | Work Lights | Refueling Pump | Jaw Deflector Plate | Grizzly Blanking Plate | Feeder Punch Plate