

CITY CAB

CANTER 616

MANUAL

2019 MODEL
ADVANCED
SAFETY
SYSTEMS



GVM:
5,995kg



Power/Torque:
110kW/370Nm



Wheelbase:
2,500mm (B)

- Electronic Brake System **NEW**
- Electronic Stability Control **NEW**
- Active Emergency Braking System **NEW**
- Lane Departure Warning System **NEW**
- 5yr/200,000km warranty **NEW**
- 30,000km service intervals

SPECIFICATIONS - 616 CITY CAB

MODEL

4x2 616 CITY CAB 5 SP. MAN FEA61BR4SFBC

WHEELBASE (mm)

2,500 (B)

GVM (kg)

5,995

GCM (kg)

9,000

ENGINE

Engine Version	FUSO 4P10-T4 Diesel
Configuration	4 Cyl. In-line DOHC, 4-Valve
Type	Variable Geometry Turbo Charged Air to Air Intercooled
Displacement	3 litre (2,998cc)
Power (DIN)	110kW @ 2840~3500rpm
Torque (DIN)	370Nm @ 1350~2840rpm
Maximum Engine Speed (rpm)	4100
Compression Ratio	17.5:1
Cooling System/Oil Cooler	Water cooled, 13.0L capacity. Engine oil cooler
Air Cleaner	Paper Element Type with Restrictor Indicator. Vertical Intake Mounted on Clean Air Side (RH)
Cold Start Preheat	Standard
Emission Control	Diesel Particulate Filter (DPF) Exhaust Dash Display DPF Status 0~9 (Empty~Full) Parked Regeneration possible from 7~9
Emission Level	EURO 5 (ADR 80/03) and EEV rated (Enhanced Environmentally-Friendly Vehicle)

4P10-T4

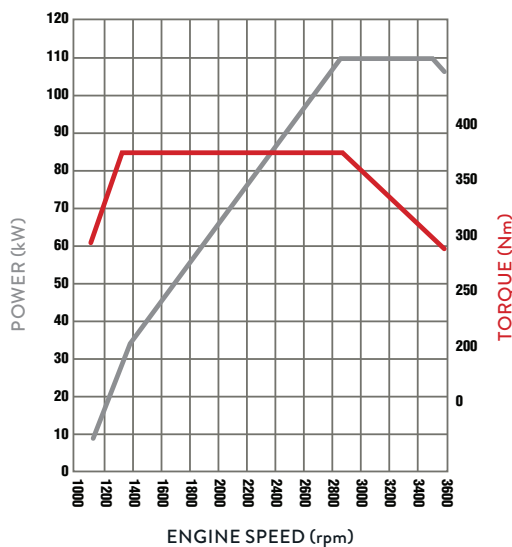

FUEL

Injection System	Bosch Common Rail Direct Injection Bosch Piezo Technology Injectors
Tank Type	Rectangular Steel Tank with Locking Cap
Fuel Capacity (L)	70
Filtration	Filter with Water Separator and Indicator Sensor

ELECTRICAL

Voltage	12V Negative Earth
Alternator Capacity	12V-110 amp
Battery Specification	Heavy Duty 115D31L x 2
Headlamp Type	Halogen 2 x 55W/60W
Fog lamp in bumper	Standard

CLUTCH

Clutch Model	FUSO C4W30
Type	Single Dry Plate, Direct Hydraulic Type, 300mm

TRANSMISSION

Version	FUSO M038S5
Type/Speeds	5 Speed with In-Dash Gearshift Lever
Features	Synchromesh 2nd-5th
Ratios	1st: 5.494 4th: 1.000 2nd: 3.193 5th: 0.723 3rd: 1.689 Rev: 5.494
PTO Opening	LH Side Direct with pump

FRONT AXLE

Axle	FUSO F200T "I" beam
Design Capacity (kg)	2,600
Max Operating Capacity (kg)	2,570

FRONT SUSPENSION

Type	Multi Leaf with Stabiliser Bar and Double Acting Shock Absorbers
Size (mm)	1,150 x 70

REAR AXLE

Axle	FUSO D03 Full Floating Banjo Type
Ratio	5.285:1
Design Capacity (kg)	4,500
Max Operating Capacity (kg)	4,500

REAR SUSPENSION

Type	Steel Suspension
Details	Multi Leaf with Stabiliser Bar and Double Acting Shock Absorbers
Size Main Leaves (mm)	1,100 x 70

STEERING

Power Assisted	Tilt/Telescopic Adjustable Steering Wheel
----------------	-------------------------------------------

BRAKES

Type	Hydraulic Dual Circuit with Front and Rear Twin Caliper Discs
Size Front/Rear (mm)	293 x 40
Features	ABS + EBD + EBS Exhaust Brake Brake Priority System
Park Brake	Transmission Mounted

SPECIFICATIONS - 616 CITY CAB

2019 MODEL
ADVANCED
SAFETY
SYSTEMS

WHEELS AND TYRES

Wheel Size	16.0 x 5.5K-115
Tyre Size Front /Rear	205/85R16 / 205/85R16 Traction
Spare Tyre Carrier	Yes

CHASSIS

Size (mm)	190 x 60 x 5
-----------	--------------

Refer to the bodybuilders guidelines on the Fuso website (www.fuso.co.nz) before mounting a body or modifying the chassis

INSTRUMENTS

Gauges	Speedometer with Odometer Tachometer Fuel Level Water Temperature
Colour Information Display	Fuel Consumption DPF Bar Chart from 1~9 Water Temperature Maintenance Reminder System Date and Time Tripmeters

STANDARD FEATURES

Cab Cooling and Heating	Air Conditioner/Heater/Demister
Accessory Power	12V Accessory Power Outlet/Cigar Lighter
Driving	Keyless Central Locking Electric Windows
Storage	Dual Overhead Storage Pockets In-Dash Centre Document Storage Door Storage Pockets Lockable Glove Box

CAB FEATURES

Type	All Steel Forward Control Manual Tilt
Mounting	Hydroelastic 4 Point
Colour	Natural White (W31)
Interior	Fully Trimmed Cab with Vinyl Floor Covering
Seating Capacity	3
Seat (driver)	Heavy Duty with LH Arm Rest Adjustable Lumbar Support
Seats (passenger)	Flat Folding, 2 Passenger Bench

SERVICE INTERVALS

30,000km / 12 months

Vehicles operating in harsh environments may be subject to reduced service intervals.

WARRANTY

5 years / 200,000km

Simply have your vehicle serviced at an authorised FUSO Service Centre, at the recommended servicing intervals, and you are covered by an additional 2 year / 100,000km FUSO warranty on top of the first 3 years / 100,000km. That's a total of 5 years / 200,000km cover. Refer to terms and conditions in the FUSO warranty booklet for full details.

NEW

SAFETY FEATURES

ACTIVE SAFETY FEATURES

Electronic Brake System (EBS)	Yes	NEW
Electronic Stability Control (ESC)	Yes	NEW
Active Emergency Braking System (AEBS)	Yes	NEW
Lane Departure Warning System (LDWS)	Yes	NEW

CAB

Structure	ECE R-29 Reinforced Cab Side Intrusion Bar
Airbags	Driver's (steering wheel) Passenger's (dashboard) NEW
Seatbelts	ELR 3-Point (+ height-adjustable with pre tensioner for driver) Lap Belt (centre passenger)
Driver's Seat	Spring-suspended
Steering Wheel	Energy-absorbing Adjustable (height and reach)
Rearview Mirrors	Heated
Fog Lamps	Yes
Keyless Central Locking	Yes
7" Touchscreen Media Unit	AM/FM/DAB + USB + AUX NEW Apple CarPlay and Android Auto Wi-Fi enabled for Internet Radio Bluetooth 32GB capacity storage HD Reverse Camera included †

CHASSIS

Speed Limiter	Yes (activated and adjustable by FUSO dealer)
Anti-Lock Braking System (ABS)	Yes
Anti-Slip Regulator (ASR)	Yes
Electronic Brake Force Distribution (EBD)	Yes
Disc Brakes	Auto-Adjusting, 4 Wheel Dual Caliper
Brake Priority System	Yes
Exhaust Brake	Yes
Hill Start Assist	Yes (adjustable engagement)
Reverse Warning Buzzer	Yes
Anti Roll Bar	Yes
Brake Wear Indicator	Yes

OPTIONS

† Additional Multimedia Display Cameras (up to 4)
Truck Specific GPS Navigation
Reversing Sensors
Tyre Pressure Monitoring System
Wireless Phone Charge Pocket

KERB WEIGHTS AND MAX AXLE LOADS (kg)

Model	Vehicle Ratings**		Max Axle Loadings**		Kerb Weights*				
	GVM	GCM	Front	Rear	Front	Rear	Total		
4x2 616 City Cab 5 Sp. MAN		FEA61BR4SFBC	5,995	9,000	2,570	4,500	1,380	640	2,020

* Weights (est.) includes 10L fuel and spare wheel and are subject to 2.5% variation (+/-)

** Vehicle ratings and max axle loadings may be limited by local regulations.

SPECIFICATIONS - 616 CITY CAB

PERFORMANCE

Turning Circle (kerb to kerb - metres)	10.2
Road Speed (km/h) at Max Engine Speed	120
Engine Speed (rpm) at 90km/hr (top gear)	2280
Gradeability at Rated GVM (theoretical)*	50%

Notes *This is theoretical performance only. Actual performance may vary under different conditions

DIMENSIONS (mm)

Wheelbase	2,500
Length Overall	4,690
Height Overall	2,130
Width Overall	1,695
Width Rear Axle	1,675
Width Front Track	1,390
Width Rear Track	1,235
Width Frame	700
Height Frame at Rear Axle	740

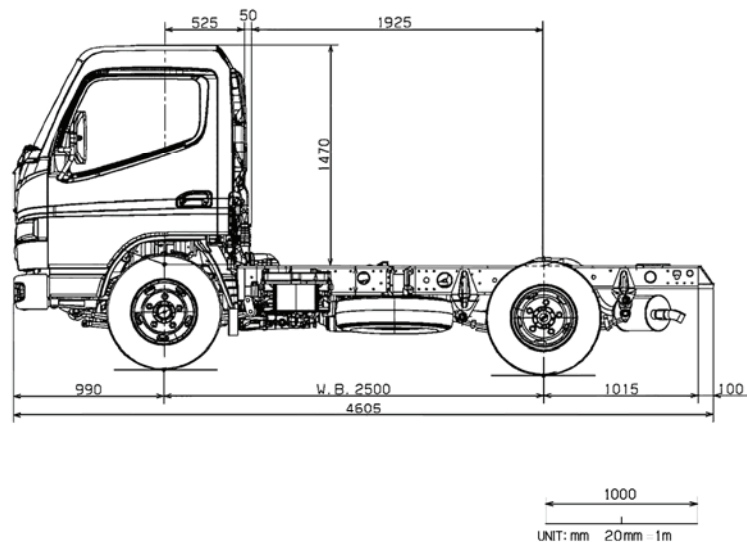

CANTER 616 CITY CAB – ‘B’ WHEELBASE

Scale = 1:50 (20mm = 1 metre). This scale is accurate when used on the original spec sheet, be aware that enlarging these illustrations can alter the scale and cause incorrect measurements. Fuso New Zealand and its authorised dealers always recommend customers seek professional advice from independent sources before commencing any engineering activities.

A policy of continual improvement means that specifications detailed in this brochure are subject to change without notice. Contact your authorised Fuso dealer to confirm current specifications. Fuso is a registered trademark of Mitsubishi Fuso Truck & Bus Corporation. Copyright © Fuso NZ (2017)