

TIPPER

FIGHTER FK1125

MY19 • 4x2 • MANUAL



GVM:
11,000kg



Power / Torque:
184kW / 761Nm



Wheelbase:
4,270mm (H)

- 30,000km service intervals
- Isringhausen driver's seat
- **NEW** 5yr / 300,000km Warranty (T&Cs inside)
- Low-height chassis
- Full air brakes for safety
- Limited Slip Differential

SPECIFICATIONS - FIGHTER FK1125

MODEL

4x2 FK1125 TIPPER 6 SP. MAN STEEL SUSP. FK62FH1RFACT)

WHEELBASE (mm)

4,270 (H)

GVM (kg)

11,000

GCM (kg)

20,000

ENGINE

| | |
|----------------------------|--|
| Engine Version | FUSO 6M60-9AT1 Diesel |
| Configuration | 6 Cyl. In-line OHC, 4-Valve |
| Type | Variable Geometry Turbo Charged Air to Air Intercooler |
| Displacement | 7.5 litre (7,545cc) |
| Power ECE Nett | 177kW @ 2500rpm |
| Torque ECE Nett | 745Nm @ 1400rpm |
| Power (JIS Gross)* | 184kW (250ps)@ 2500rpm |
| Torque (JIS Gross)* | 761Nm (561lb/ft) @ 1400rpm |
| Maximum Engine Speed (rpm) | 2900 |
| Compression Ratio | 16.0:1 |
| Cooling System/Oil Cooler | Water cooled with Viscous fan, 23.0L capacity. Engine oil cooler |
| Air Cleaner | Paper Element Type with Restrictor Indicator. Vertical Intake Mounted on Clean Air Side (RH) |
| Cold Start Preheat | Standard |
| Emission Control | Selective Catalytic Reduction (SCR) After-Treatment System (BlueTec), Positive Crankcase Ventilation (PCV) |
| Emission Level | EURO 5 (ADR 80/03) |

*Calculated

6M60-9AT1

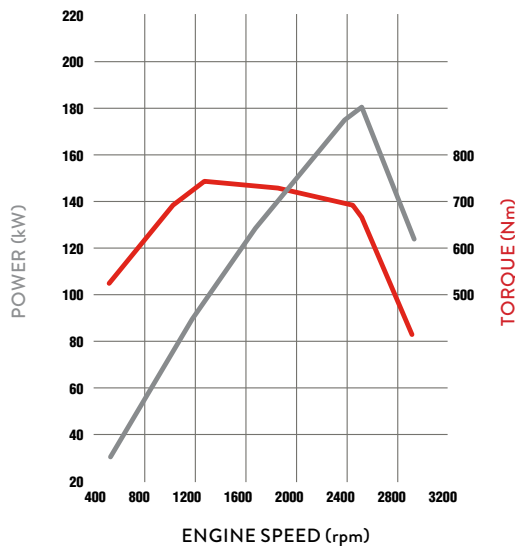

FUEL

| | |
|-----------------------------------|---|
| Injection System | DENSO Common Rail System Electronically Controlled Direct Injection |
| Tank Type | Rectangular Steel Tank with Locking Cap |
| Fuel Capacity (L) | 200 |
| AdBlue Exhaust Fluid Capacity (L) | 25 |

ELECTRICAL (continued)

| | |
|-----------------------|--------------------------------|
| Voltage | 24V Negative Earth |
| Alternator Capacity | 24V-80 amp |
| Battery Specification | Heavy Duty 2 x 12V, 100Ah/20hr |
| Headlamp Type | Halogen 2 x 70W/75W |

CLUTCH

| | |
|-------------------------|---------------------------------|
| | Manual |
| Clutch Model | FUSO C7M38 |
| Type | Single Plate Cerametallic 380mm |
| Operation/Specification | Air Assisted Hydraulic |

TRANSMISSION

| | |
|-------------|--|
| | Manual |
| Version | FUSO Manual M070S6-OD |
| Type/Speeds | 6 with Air Assisted Gearshift |
| Features | Synchromesh 2nd-6th |
| Ratios | 1st: 6.807 2nd: 4.172 3rd: 2.396 4th: 1.504 5th: 1.000 6th: 0.774 Rev. 6.807 |
| PTO Opening | LH Side |

PROPELLER SHAFT

| | |
|-----------------|---------------|
| | Manual |
| Type | P10 |
| Universal Joint | Needle Roller |

FRONT AXLE

| | |
|-----------------------------|---------------------|
| Axle | FUSO F500T "I" Beam |
| Design Capacity (kg) | 5,000 |
| Max Operating Capacity (kg) | 4,480 |

FRONT SUSPENSION

| | |
|-----------|---|
| Type | Taper Leaf spring with Stabiliser Bar and Double Acting Shock Absorbers |
| Size (mm) | 1,300 x 70 |

REAR AXLE

| | |
|-----------------------------|--|
| Axle | FUSO D052 Full Floating Hypoid + Limited Slip Differential |
| Design Capacity (kg) | 9,500 |
| Max Operating Capacity (kg) | 8,480 |
| Ratio | Manual: 4.625:1 |

SPECIFICATIONS - FIGHTER FK1125

REAR SUSPENSION

| | |
|-------------------------|---------------------------------------|
| Type | Steel Suspension |
| Details | Multi Leaf spring with Stabiliser Bar |
| Size Main Leaves (mm) | 1,300 x 70 |
| Size Helper Leaves (mm) | 900 x 70 |

STEERING

| | |
|----------------|---|
| Power Assisted | Tilt/Telescopic Adjustable Steering Wheel |
|----------------|---|

BRAKES

| | |
|------------------------|--|
| Type | Full Air, Dual Circuit, FUSO Taper Roller, Automatic Brake Adjustment, ABS |
| ASR (Traction Control) | Yes |
| Size Front / Rear (mm) | 370 x 150 |
| Park Brake | Rear Wheel Spring Actuated |
| Auxiliary | Exhaust Brake |
| Compressor | Water Cooled, 340cc Single Cylinder with Air Dryer |

WHEELS AND TYRES

| | |
|--------------------|-----------------------|
| Wheel Type | 7, Single Piece Disc |
| Wheel Size | 19.5 x 6.75DC-147-13t |
| Wheel Stud Pattern | 8 Stud 275mm PCD ISO |
| Tyre Size All | 245/70R19.5 |
| Spare Tyre Carrier | Provided |

CHASSIS

| | |
|------------|------------------|
| Type | Parallel Channel |
| Size (mm) | 230 x 80 x 7.0 |
| Width (mm) | 844 |

Refer to the bodybuilders guidelines on the Fuso website (www.fuso.co.nz) before mounting a body or modifying the chassis

INSTRUMENTS

| | |
|----------------------------|--|
| Gauges | Speedometer with Odometer, Tachometer, Air Pressure (2), Fuel Level, Water Temperature |
| Colour Information Display | Fuel Consumption, Service Indicators, Hour Meter and Tripmeter |

STANDARD FEATURES

| | |
|-----------------------------|--|
| Airbag | Driver's Air Bag and Seat Belt Pre-tensioner |
| Hill Start System | Yes |
| Cab Cooling and Heating | Air Conditioner/Heater/Demister |
| Accessory Power | 24V Accessory Power Outlet/Cigar Lighter |
| 6.2" Touchscreen Media Unit | AM/FM/DAB + USB + AUX, Apple Carplay / Android Auto, Wi-Fi Enabled for Internet Radio, Bluetooth, 32GB Storage Capacity, HD Infrared Reverse Camera (see options) NEW |
| Driving | Keyless Central Locking, Electric Windows, Cruise Control, LH Transom Window, Cup Holders (4), Rear Quarter Glass, Fluorescent Cabin Lamp and Interior Reading Lamps, Engine Idle Speed Control |
| Storage | Centre Seat Storage Console, Rear Bunk Storage Pocket, Dash Storage Tray 2 DIN Glove Compartment, 1 Single and 1 Double DIN Slot for Accessories, Overhead Storage Pocket with Lid, RH Door Storage Pocket |

KERB WEIGHTS AND MAX AXLE LOADS (kg)

| Model | | Vehicle Ratings** | | Max Axle Loadings** | | Kerb Weights* | | |
|---|-----------------|-------------------|--------|---------------------|-------|---------------|-------|-------|
| | | GVM | GCM | Front | Rear | Front | Rear | Total |
| 4x2 FK1125 Tipper 6 Sp. Man Steel Susp. | FK62FHY1RFAC(T) | 11,000 | 20,000 | 4,480 | 8,480 | 2,610 | 2,480 | 5,090 |

* Weights (est.) includes 10L fuel and spare wheel and are subject to 2.5% variation (+/-) ** Vehicle ratings and max axle loadings may be limited by local regulations.

STANDARD FEATURES (continued)

| | |
|---------------|--|
| Cab: External | Roof Mounting Points (max. static load 70kg) Front End-Outline Marker Lamps |
| Chassis | Mounted Tool Box, Reverse Warning Buzzer |

CAB FEATURES

| | |
|---------------------|---|
| Type | All Steel Forward Control, Manual Tilt 44 deg. |
| Mounting | Hydroelastic Susp. 4 Point |
| Colour | Natural White (W31) |
| Interior | Fully Trimmed |
| Windscreen | Laminated Tinted |
| Windscreen Wipers | 2 Speed + Intermittent Cycle with Integrated Washer Nozzles |
| Door | 90 degree Opening Angle |
| Rear Vision Mirrors | Remote/Heated with Convex Spotter (Both Sides) |
| Seating Capacity | 3 |
| Seat Belts | 2 ELR Lap Sash, 1 Lap |
| Seat (driver) | ISRI Air Susp. + Auto Levelling, Height, Tilt, Lumbar, Bolster and Dampening Adjust, Integral Headrest, Fabric Trim NEW |
| Seats (passenger) | Centre: Low Back with Fabric Trim and Forward Folding LH Passenger: Fixed Base with Reclining Seat Back, Integral Headrest and Fabric Trim |

SERVICE INTERVALS

30,000km full service / 15,000km safety inspection
30,000km full service intervals, depending on application/use.
15,000km safety inspection, with greasing, required for reliability and to maintain warranty cover.

WARRANTY

5 years / 300,000km **NEW**
Simply have your vehicle serviced at an authorised FUSO Service Centre, at the recommended servicing intervals, and you are covered by an additional 2 year / 150,000km FUSO warranty on top of the first 3 years / 150,000km. That's a total of 5 years / 300,000km cover.
Tipper body covered by 12mth / unlimited km warranty.
Refer to terms and conditions in the FUSO warranty booklet for full details.

OPTIONS

Additional Cameras for Media Unit (up to 4) **NEW**
Truck Specific GPS Navigation
Reverse Sensors
Tyre Pressure Monitoring System (up to 36 tyres)
Wireless Phone Charging Pocket

PERFORMANCE

| | Manual |
|--|--------|
| Turning Circle (kerb to kerb - metres) | 15.2 |
| Electronically Speed Limited to (km/h): | 100 |
| Engine Speed (rpm) at 90km/hr (top gear) | 2,050 |
| Gradeability at Rated GVM (theoretical)* | 51% |
| Gradeability at Rated GCM (theoretical)* | 25% |

*Theoretical performance only. Actual performance may vary under different conditions

SPECIFICATIONS - FIGHTER FK1125

DIMENSIONS (mm)

| | |
|---------------------------|-------|
| Wheelbase | 4,270 |
| Length Overall | 6,995 |
| Height Overall | 2,480 |
| Width Overall | 2,280 |
| Width Rear Axle | 2,280 |
| Width Front Track | 1,780 |
| Width Rear Track | 1,710 |
| Width Frame | 844 |
| Height Frame at Rear Axle | 920 |

REAR BODY

| | |
|---|--|
| Type: | Tipper Body |
| Body Capacity (m ³): | 3.5 |
| Inside Body Dimensions (mm): | |
| Length x Width x Height | 4,000 x 2,060 x 430 |
| Floor Height From Ground to Rear Deck Floor | 1,215 |
| Thickness : Floor | 4.5 |
| Front, Side & Tailgate Panel | 3.2 |
| Sides and Tailgate Operation | Drop sides with two-way tailgate hinging at the top & bottom |
| Tipping Mechanism: | Under body hydraulic cylinder with link |
| Tipping Performance: Tip Angle (deg) | 50 |
| Lifting Time (sec) | 20 |
| Lowering Time (sec) | 20 |

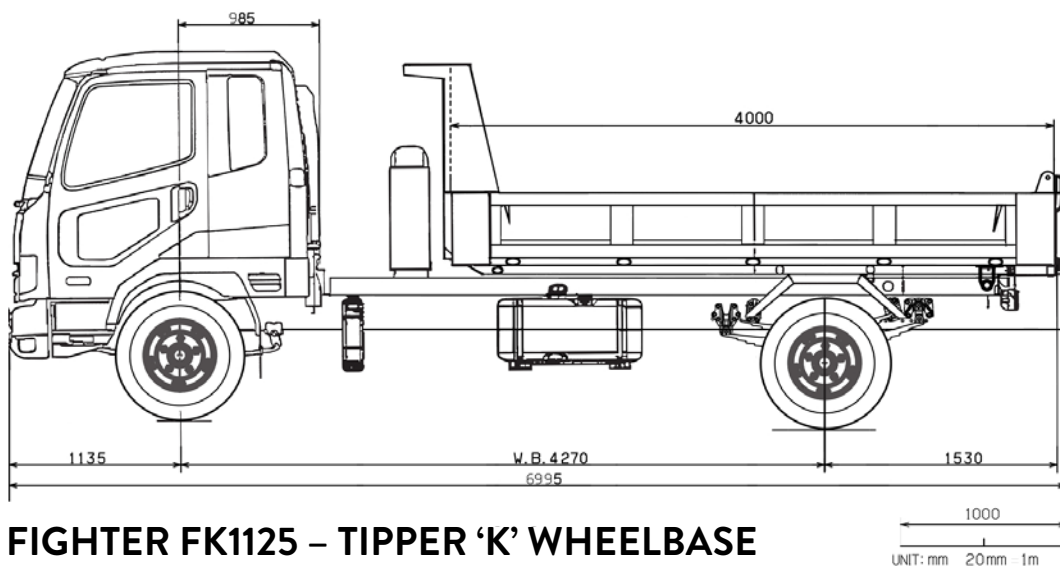

Scale = 1:50 (20mm = 1 metre). This scale is accurate when used on the original spec sheet, be aware that enlarging these illustrations can alter the scale and cause incorrect measurements. Fuso New Zealand and its authorised dealers always recommend customers seek professional advice from independent sources before commencing any engineering activities.

A policy of continual improvement means that specifications detailed in this brochure are subject to change without notice. Contact your authorised Fuso dealer to confirm current specifications. Fuso is a registered trademark of Mitsubishi Fuso Truck & Bus Corporation. Copyright © Fuso NZ (2019)