

LONG WHEELBASE

# FIGHTER FN2428

MY19 • 6x4 • MANUAL OR ALLISON AUTO



**GVM:**  
24,000kg



**Power / Torque:**  
207kW / 802Nm



**Wheelbase:**  
6,530mm (U)

- 30,000km service intervals
- Isringhausen driver's seat
- **NEW** 5yr / 300,000km Warranty (T&Cs inside)
- Rear air suspension
- 6.5T front axle

# SPECIFICATIONS - FIGHTER FN2428 LWB

## MODEL

6x4 FN2428	9 SP.	MAN	AIR SUSP.	FN64FU2RFAK
6x4 FN2428	6 SP.	AUTO	AIR SUSP.	FN64FU2RFAM

## WHEELBASE (mm)

6,530
6,530

## GVM (kg) (optional)

24,000 (18,000)
24,000 (18,000)

## GCM (kg)

34,000
34,000

## ENGINE

Engine Version	FUSO 6M60-9AT2 Diesel
Configuration	6 Cyl. In-line OHC, 4-Valve
Type	Variable Geometry Turbo Charged Air to Air Intercooler
Displacement	7.5 litre (7545cc)
Power ECE Nett	199kW @ 2500rpm
Torque ECE Nett	785Nm @ 1100-2400rpm
Power (JIS Gross)*	207kW (281ps) @ 2500rpm
Torque (JIS Gross)*	802Nm(592lbft) @ 1100-2400rpm
Maximum Engine Speed (rpm)	2900
Compression Ratio	16.0:1
Cooling System / Oil Cooler	Water cooled with Viscous fan, 23.0L capacity. Engine oil cooler
Air Cleaner	Paper Element Type with Restrictor Indicator. Vertical Intake Mounted on Clean Air Side (RH)
Cold Start Preheat	Standard
Emission Control	Selective Catalytic Reduction (SCR) After-Treatment System(BlueTec), Positive Crankcase Ventilation (PCV)
Emission Level	Euro 5 (ADR 80/03)

\*Calculated

## 6M60-9AT2

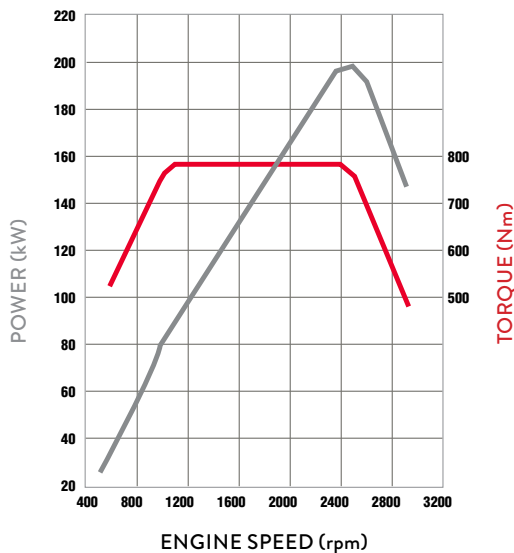

## FUEL

Injection System	DENSO Common Rail System Electronically Controlled Direct Injection
Fuel Tank	Rectangular Alloy Tank with Locking Cap
Fuel Capacity (L)	400
AdBlue Exhaust Fluid Capacity (L)	40

## ELECTRICAL

Voltage	24V Negative Earth
Alternator Capacity	24V-80 amp

## ELECTRICAL (continued)

Battery Specification	Heavy Duty 2 x 12V, 100Ah/20hr
Headlamp Type	Halogen 2 x 70W/75W

## CLUTCH

Clutch Model	FUSO C7M38 (manual only)
Type (mm)	Single Plate Cerametallic 380
Operation / Specification	Air Assisted Hydraulic

## TRANSMISSION

	Manual	Auto
Version	Eaton Manual ES-11109 (Fuso Code M060S9)	Allison Automatic MD3500 (M100A6)
Type/Speeds	9 Speed	6 Speed
Features	Synchromesh 1L-4H	Generation 5 Control Systems
Ratios	Low Range High Range Low: 12.64 1st: 2.48 1st: 8.81 2nd: 1.85 2nd: 6.55 3rd: 1.34 3rd: 4.77 4th: 1.00 4th: 3.55 Rev: 13.21	1st: 4.593 2nd: 2.257 3rd: 1.535 4th: 1.000 5th 0.749 6th 0.651 Rev. 4.999
Torque Converter/ Stall Torque Ratio	N/A	TC415/2.35
Automatic Transmission Fluid Cooling	N/A	2 Chassis Mounted Coolers (LH and RH Side)
PTO Opening	LH Side and Rear	4 o'clock and 8 o'clock

## PROPELLER SHAFT

Type	P140 / P8
Universal Joint	Needle Roller

## FRONT AXLE

Axle	FUSO F650T "I" Beam
Design Capacity (kg)	6,500
Max Operating Capacity (kg)	6,500

## FRONT SUSPENSION

Type	Taper Leaf with Double Acting Shock Absorbers
Size (mm)	1400 x 80 Leaves

## REAR AXLE

Type	Full Floating Hypoid, Tandem Drive with Inter-Axle Diff Lock
Axle Version	FUSO D10HT / 10H
Design Capacity (kg)	21,600
Max Operating Capacity (kg)	18,000
Ratio	Manual 4.222:1 Auto 6.166:1

## REAR SUSPENSION

Type	Air Suspension
Details	Trailing Arm with Air Dump Control and Double Acting Shock Absorbers Air Spring - 2x250mm dia. per axle Trailing Arm - 2 leaf

# SPECIFICATIONS - FIGHTER FN2428 LWB

## STEERING

Power Assisted	Tilt / Telescopic Adjustable Steering Wheel
----------------	---

## BRAKES

Type	Full Air, Dual Circuit, FUSO Taper Roller, Automatic Brake adjustment, ABS
ASR (Traction Control)	Yes (Not available on auto model)
Size Front / Rear (mm)	410 x 150 / 410 x 200
Park Brake	Rear Wheel Spring Actuated
Auxiliary	Exhaust Brake
Compressor	Water Cooled, 340cc Single Cylinder with Air Dryer

## WHEELS AND TYRES

Wheel Type	11, Single Piece Steel Disc
Wheel Size	22.5x8.25DC-165-13t
Wheel Stud Pattern	10 stud 335mm PCD
Tyre Size All	275 / 70R22.5
Spare Tyre Carrier	Provided

## CHASSIS

Type	Reinforced Parallel Channel
Size (mm)	280 x 90 x 8.0
Width (mm)	841

## INSTRUMENTS

Gauges	Speedometer with Odometer, Tachometer; Air Pressure (2); Fuel Level; Water Temperature
Colour Information Display	Fuel Consumption; Service Indicators Hour Meter and Tripmeter

## STANDARD FEATURES

Airbag	Driver's Air Bag and Seat Belt Pre-tensioner
Hill Start System	Yes (Not available on auto model)
Cab Cooling and Heating	Air Conditioner/Heater/Demister
Accessory Power	24V Accessory Power Outlet/Cigar Lighter
6.2" Touchscreen Media Unit	AM/FM/DAB + USB + AUX, Apple Carplay / Android Auto, Wi-Fi Enabled for Internet Radio, Bluetooth, 32GB Storage Capacity, HD Infrared Reverse Camera (see options) <b>NEW</b>
Driving	Keyless Central Locking, Electric Windows, Cruise Control, LH Transom Window, Cup Holders (4), Rear Quarter Glass, Fluorescent Cabin Lamp and Interior Reading Lamps, Engine Idle Speed Control
Storage	Centre Seat Storage Console, Rear Bunk Storage Pocket, Dash Storage Tray 2 DIN Glove Compartment, 1 Single and 1 Double DIN Slot for Accessories, Overhead Storage Pocket with Lid, RH Door Storage Pocket
Cab: External	Roof Mounting Points (max. static load 70kg) Front End-Outline Marker Lamps

## STANDARD FEATURES (continued)

Chassis	Chassis Mounted Tool Box Reverse Warning Buzzer
---------	---

## CAB FEATURES

Type	All Steel Forward Control; Manual Tilt 44 deg.
Mounting	Hydroelastic Susp. 4 Point
Colour	Natural White (W31)
Interior	Fully Trimmed
Windscreen	Laminated Tinted
Windscreen Wipers	2 Speed + Intermittent Cycle with Integrated Washer Nozzles
Door	90 degree Opening Angle
Rear Vision Mirrors	Remote Control /Heated with Convex Spotter (Both Sides)
Seating Capacity	3
Seat Belts	Lap Sash Belts for Outside Seating Positions Lap Belt for Centre Seat
Seat (driver)	ISRI Air Susp. + Auto Levelling, Height, Tilt, Lumbar, Bolster and Dampening Adjust, Integral Headrest, Fabric Trim <b>NEW</b>
Seats (passenger)	Centre: Low Back with Fabric Trim and forward folding Far Passenger: Fixed Base with Reclining Seat Back, Integral Headrest and Fabric Trim

## OPTIONS

Additional Cameras for Media Unit (up to 4), Truck Specific GPS Navigation, Reverse Sensors, Tyre Pressure Monitoring System (up to 36 tyres), Wireless Phone Charging Pocket **NEW**

## SERVICE INTERVALS

**30,000km full service / 15,000km safety inspection**  
30,000km full service intervals, depending on application/use.  
15,000km safety inspection, with greasing, required for reliability and to maintain warranty cover.

## WARRANTY

**5 years / 300,000km** **NEW**  
Simply have your vehicle serviced at an authorised FUSO Service Centre, at the recommended servicing intervals, and you are covered by an additional 2 year / 100,000km FUSO warranty on top of the first 3 years / 200,000km. That's a total of 5 years / 300,000km cover.  
Refer to terms and conditions in the FUSO warranty booklet for full details.

## PERFORMANCE

	Manual	Auto
Turning Circle (kerb to kerb - metres)	21.8	21.8
Electronically Speed Limited to (km/hr):	100	100
Engine Speed (rpm) at 90km/hr (top gear)	2185	1970
Gradeability at Rated GVM (theoretical)*	32%	38%
Gradeability at Rated GCM (theoretical)*	22%	25%

\*Theoretical performance only. Actual performance may vary under different conditions

## KERB WEIGHTS AND MAX AXLE LOADS (kg)

Model	Vehicle Ratings**		Max Axle Loadings**		Kerb Weights*			
	GVM	GCM	Front	Rear	Front	Rear	Total	
6x4 FN2428 9 Sp. Man Air Susp.	FN64FU2RFAK	24,000	34,000	6,500	18,000	3,135	3,520	6,655
6x4 FN2428 6 Sp. Auto Air Susp.	FN64FU2RFAM	24,000	34,000	6,500	18,000	3,205	3,570	6,775
6x4 FN1828 9 Sp. Man Air Susp.	FN64FU2RFAK(D)	18,000	34,000	6,500	18,000	3,135	3,520	6,655
6x4 FN1828 6 Sp. Auto Air Susp.	FN64FU2RFAM(D)	18,000	34,000	6,500	18,000	3,205	3,570	6,775

\* Weights (est.) includes 10L fuel and spare wheel and are subject to 2.5% variation (+/-)

\*\* Vehicle ratings and max axle loadings may be limited by local regulations.

# SPECIFICATIONS - FIGHTER FN2428 LWB

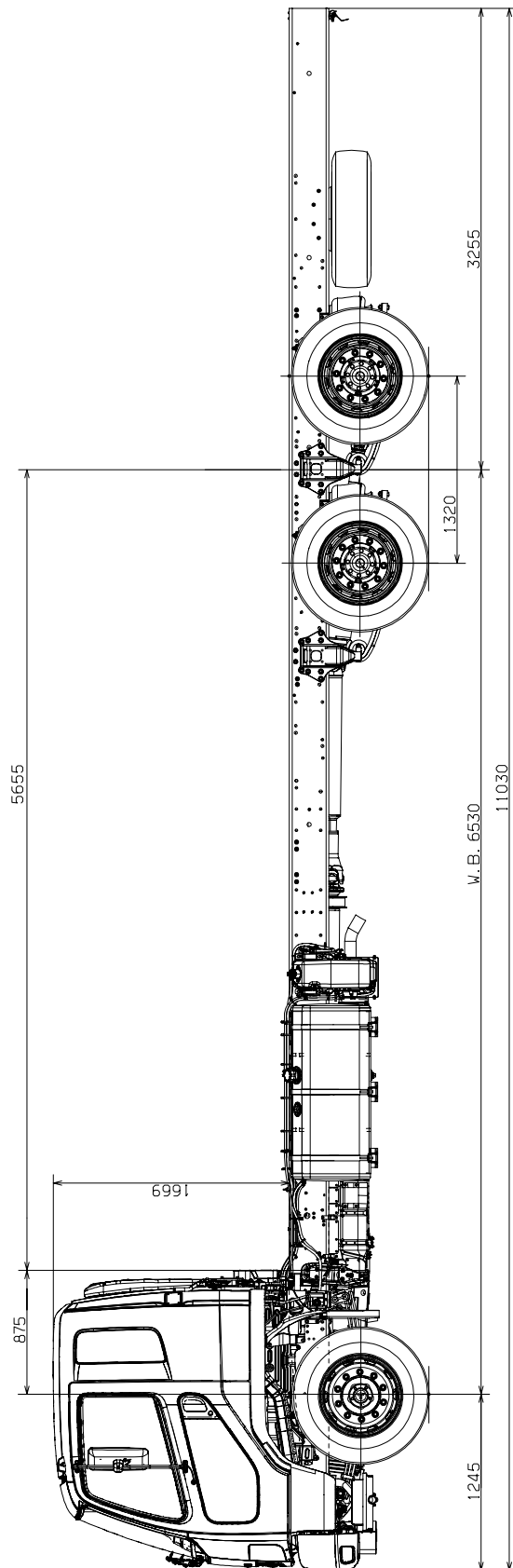

## FIGHTER FN2428 – 'U' WHEELBASE

### DIMENSIONS (mm)

Wheelbase	6,530
Length Overall	11,030
Height Overall	2,630
Width Overall	2,470
Width Rear Axle	2,470
Width Front Track	1,925
Width Rear Track	1,850
Width Frame	841
Height Frame at Rear Axle	A/sus = 967 inflated

Scale = 1:50 (20mm = 1 metre). This scale is accurate when used on the original spec sheet, be aware that enlarging these illustrations can alter the scale and cause incorrect measurements. Fuso New Zealand and its authorised dealers always recommend customers seek professional advice from independent sources before commencing any engineering activities.

A policy of continual improvement means that specifications detailed in this brochure are subject to change without notice. Contact your authorised Fuso dealer to confirm current specifications. Fuso is a registered trademark of Mitsubishi Fuso Truck & Bus Corporation. Copyright © Fuso NZ (2017)