

CYJ 530



Chrome appearance grille available on 530 models only
Vehicle shown not representative of CYJ 530

WEIGHT RATINGS

| | |
|------------|-----------|
| GVM | 29,000 kg |
| GCM | 55,000 kg |

ENGINE

| | |
|---------------|--------------------------------------|
| POWER | 382 kW (520PS) @ 1,800 rpm (DIN NET) |
| TORQUE | 2,256 Nm @ 900 - 1,300 rpm (DIN NET) |

TRANSMISSION

| |
|---|
| 18 speed manual transmission (MT) |
| 16 speed automated manual transmission (AMT) |

* Refer to back page for detailed weight rating information

| INTELLIGENT SAFETY | |
|--|--|
| ACTIVE SAFETY ADVANCED DRIVER ASSISTANCE SYSTEMS (ADAS) | Advanced Emergency Brake System (AEB) |
| | Adaptive Cruise Control (AMT only) (ACC) |
| | Adaptive Driving Beam headlights (ADB) |
| | Anti Skid Regulator (ASR) |
| | Anti Lock Braking System (ABS) |
| | Automatic Lighting System (ALS) |
| | Distance Warning System (DWS) |
| | Electronic Brake System (EBS) |
| | Electronic Stability Control (ESC) |
| | Forward Collision Warning (FCW) |
| | Hill Start Aid (MT only) (HSA) |
| PASSIVE SAFETY CABIN OCCUPANT SAFETY SYSTEMS (COSS) | Lane Departure Warning (LDW) |
| | Traffic Movement Warning (TMW) |
| | Vehicle Assistance Technology (VAT) |
| | Drivers side airbag & seatbelt pretensioner Multi-function steering wheel controls Internally reinforced doors |

| ISUZU WARRANTY COVER | |
|----------------------|------------------------------|
| WARRANTY | 5 Year / 500,000km Warranty* |

| ENGINE | |
|-------------------------|--|
| DESCRIPTION | Isuzu 6WG1 - TCS |
| TYPE | 6 cylinder 24 valve SOHC |
| DISPLACEMENT | 15,681 cc |
| BORE X STROKE | 147mm x 154mm |
| POWER | 382 kW (520PS) @ 1,800 rpm (DIN NET) |
| TORQUE | 2,256 Nm @ 900 - 1,300 rpm (DIN NET) |
| INDUCTION | Electronically controlled variable nozzle turbocharger with air-to-air intercooler |
| FUEL INJECTION | Direct injection high pressure common rail |
| EMISSION CONTROL | Selective Catalytic Reduction (SCR). Euro V compliant |

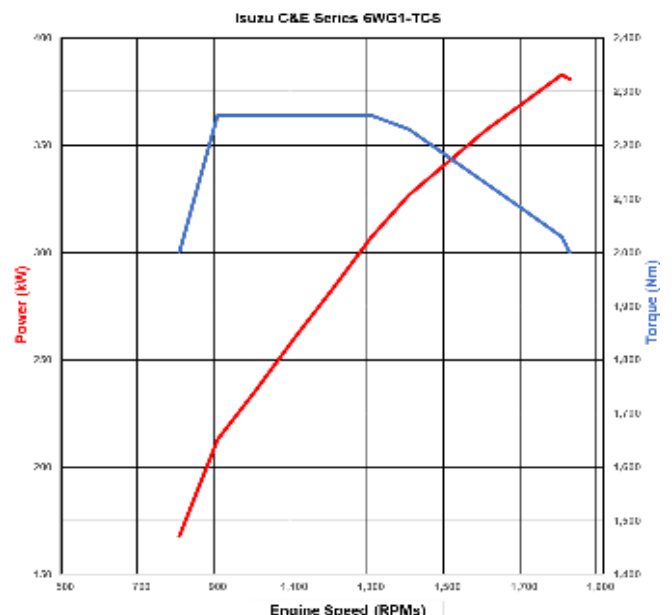

| CLUTCH | |
|--------|---|
| MT | Type: Eaton twin plate with clutch brake |
| | Clutch Plate Diameter: 394mm (15.5") |
| AMT | Type: Diaphragm twin plate pull type |
| | Clutch Plate Diameter: 394mm (15.5") |

| TRANSMISSION | | | | | | | | | | | | | | | | | | | | | | | | | | | | | | | | | | | | | | | | | | | |
|---|--|-------|-------|------|------|------|-----|-----|-------|-------|------|------|------|------|------|-----|-----|------|------|------|------|------|------|------|------|------|------|------|------|------|------|------|------|--|--|--|------|------|-------|-------|--|--|--|
| MT | Description: Eaton RTL018918B | | | | | | | | | | | | | | | | | | | | | | | | | | | | | | | | | | | | | | | | | | |
| | Type: 18 speed manual constant mesh | | | | | | | | | | | | | | | | | | | | | | | | | | | | | | | | | | | | | | | | | | |
| | Ratios: | | | | | | | | | | | | | | | | | | | | | | | | | | | | | | | | | | | | | | | | | | |
| | <table border="1"> <thead> <tr> <th>1ST</th> <th>2ND</th> <th>3RD</th> <th>4TH</th> <th>5TH</th> <th>6TH</th> <th>7TH</th> </tr> </thead> <tbody> <tr> <td>14.40</td> <td>12.29</td> <td>8.56</td> <td>7.30</td> <td>6.05</td> <td>5.15</td> <td>4.38</td> </tr> <tr> <th>8TH</th> <th>9TH</th> <th>10TH</th> <th>11TH</th> <th>12TH</th> <th>13TH</th> <th>14TH</th> </tr> <tr> <td>3.74</td> <td>3.20</td> <td>2.73</td> <td>2.29</td> <td>1.92</td> <td>1.62</td> <td>1.38</td> </tr> <tr> <th>15TH</th> <th>16TH</th> <th>17TH</th> <th>18TH</th> <td></td> <td></td> <td></td> </tr> <tr> <td>1.17</td> <td>1.00</td> <td>0.86</td> <td>0.73</td> <td></td> <td></td> <td></td> </tr> </tbody> </table> | 1ST | 2ND | 3RD | 4TH | 5TH | 6TH | 7TH | 14.40 | 12.29 | 8.56 | 7.30 | 6.05 | 5.15 | 4.38 | 8TH | 9TH | 10TH | 11TH | 12TH | 13TH | 14TH | 3.74 | 3.20 | 2.73 | 2.29 | 1.92 | 1.62 | 1.38 | 15TH | 16TH | 17TH | 18TH | | | | 1.17 | 1.00 | 0.86 | 0.73 | | | |
| | 1ST | 2ND | 3RD | 4TH | 5TH | 6TH | 7TH | | | | | | | | | | | | | | | | | | | | | | | | | | | | | | | | | | | | |
| 14.40 | 12.29 | 8.56 | 7.30 | 6.05 | 5.15 | 4.38 | | | | | | | | | | | | | | | | | | | | | | | | | | | | | | | | | | | | | |
| 8TH | 9TH | 10TH | 11TH | 12TH | 13TH | 14TH | | | | | | | | | | | | | | | | | | | | | | | | | | | | | | | | | | | | | |
| 3.74 | 3.20 | 2.73 | 2.29 | 1.92 | 1.62 | 1.38 | | | | | | | | | | | | | | | | | | | | | | | | | | | | | | | | | | | | | |
| 15TH | 16TH | 17TH | 18TH | | | | | | | | | | | | | | | | | | | | | | | | | | | | | | | | | | | | | | | | |
| 1.17 | 1.00 | 0.86 | 0.73 | | | | | | | | | | | | | | | | | | | | | | | | | | | | | | | | | | | | | | | | |
| Reverse: L/L 15.05, L/H 12.86, H/L 4.03, H/H 3.43 | | | | | | | | | | | | | | | | | | | | | | | | | | | | | | | | | | | | | | | | | | | |
| Power Take Off facility: Provision on bottom & RHS transmission case | | | | | | | | | | | | | | | | | | | | | | | | | | | | | | | | | | | | | | | | | | | |
| AMT | Description: Isuzu MJX16 | | | | | | | | | | | | | | | | | | | | | | | | | | | | | | | | | | | | | | | | | | |
| | Type: 16 speed Automated Manual synchromesh | | | | | | | | | | | | | | | | | | | | | | | | | | | | | | | | | | | | | | | | | | |
| | Ratios: | | | | | | | | | | | | | | | | | | | | | | | | | | | | | | | | | | | | | | | | | | |
| | <table border="1"> <thead> <tr> <th>1ST</th> <th>2ND</th> <th>3RD</th> <th>4TH</th> <th>5TH</th> <th>6TH</th> <th>7TH</th> </tr> </thead> <tbody> <tr> <td>14.01</td> <td>11.34</td> <td>9.93</td> <td>8.03</td> <td>6.84</td> <td>5.53</td> <td>4.58</td> </tr> <tr> <th>8TH</th> <th>9TH</th> <th>10TH</th> <th>11TH</th> <th>12TH</th> <th>13TH</th> <th>14TH</th> </tr> <tr> <td>3.71</td> <td>3.05</td> <td>2.47</td> <td>2.16</td> <td>1.75</td> <td>1.49</td> <td>1.20</td> </tr> <tr> <th>15TH</th> <th>16TH</th> <th>REV1</th> <th>REV2</th> <td></td> <td></td> <td></td> </tr> <tr> <td>1.00</td> <td>0.81</td> <td>12.58</td> <td>10.18</td> <td></td> <td></td> <td></td> </tr> </tbody> </table> | 1ST | 2ND | 3RD | 4TH | 5TH | 6TH | 7TH | 14.01 | 11.34 | 9.93 | 8.03 | 6.84 | 5.53 | 4.58 | 8TH | 9TH | 10TH | 11TH | 12TH | 13TH | 14TH | 3.71 | 3.05 | 2.47 | 2.16 | 1.75 | 1.49 | 1.20 | 15TH | 16TH | REV1 | REV2 | | | | 1.00 | 0.81 | 12.58 | 10.18 | | | |
| | 1ST | 2ND | 3RD | 4TH | 5TH | 6TH | 7TH | | | | | | | | | | | | | | | | | | | | | | | | | | | | | | | | | | | | |
| 14.01 | 11.34 | 9.93 | 8.03 | 6.84 | 5.53 | 4.58 | | | | | | | | | | | | | | | | | | | | | | | | | | | | | | | | | | | | | |
| 8TH | 9TH | 10TH | 11TH | 12TH | 13TH | 14TH | | | | | | | | | | | | | | | | | | | | | | | | | | | | | | | | | | | | | |
| 3.71 | 3.05 | 2.47 | 2.16 | 1.75 | 1.49 | 1.20 | | | | | | | | | | | | | | | | | | | | | | | | | | | | | | | | | | | | | |
| 15TH | 16TH | REV1 | REV2 | | | | | | | | | | | | | | | | | | | | | | | | | | | | | | | | | | | | | | | | |
| 1.00 | 0.81 | 12.58 | 10.18 | | | | | | | | | | | | | | | | | | | | | | | | | | | | | | | | | | | | | | | | |
| Power Take Off facility: Provision on LHS of transmission case | | | | | | | | | | | | | | | | | | | | | | | | | | | | | | | | | | | | | | | | | | | |

| AXLES | |
|-------|---|
| FRONT | Description: Isuzu F066 tandem steer |
| | Type: Reverse Elliot I-beam |
| | Capacity: 13,200 kg (combined) |
| REAR | Description: Isuzu RT210 |
| | Type: Hypoid tandem drive with inter-axle lock |
| | Capacity: 21,000 kg |
| | Ratio: 4.10:1 |

| SUSPENSION | |
|------------|--|
| FRONT | Tapered parabolic leaf springs with double acting shock absorbers & stabiliser bar on 1st axle |
| REAR | Isuzu 8-bag air suspension with stabilizer bars & hydraulic shock absorbers on both axles |

| BRAKES | |
|---|--|
| TYPE | Dual circuit drum brake system featuring: |
| | - Electronic Brake System (EBS) |
| | - Electronic Stability Control (ESC) |
| | - Hill Start Assist (HSA) (MT only) |
| - Advanced Emergency Brake System (AEB) | |
| DIAMETER FRONT | 410mm x 160mm |
| DIAMETER REAR | 410mm x 220mm |
| PARK BRAKE | Spring operated on rear axles |
| AUXILIARY BRAKE | Isuzu air operated exhaust brake Isuzu magnetic driveshaft retarder |

| STEERING | |
|------------------|--|
| TYPE | Recirculating ball with integral power assistance |
| WHEEL LOCK ANGLE | Axle one: Inner 47° / Outer 36° Axle two: Inner 39° / Outer 31° |

| WHEELS & TYRES | |
|----------------|---|
| FRONT | Wheels: 22.5" x 8.25" 165mm offset, steel disc |
| | Tyres: 275/70R22.5 148/145 |
| | Max tyre rating: 12,600 kg (combined) |
| REAR | Wheels: 22.5" x 8.25" 165mm offset, Alcoa alloy disc |
| | Tyres: 275/70R22.5 148/145 |
| | Max tyre rating: 23,200 kg |

| CHASSIS FRAME | |
|---------------|--|
| TYPE | Rolled steel channel. Cold riveted ladder frame HT540 weldable steel |
| DIMENSIONS | 285mm x 85mm x 7mm |

| FUEL TANK & ADBLUE TANK | |
|-------------------------|--|
| TYPE | Frame mounted alloy fuel tank LHS. Frame mounted AdBlue tank LHS |
| CAPACITY | Diesel = 400L / AdBlue = 75L |
| FUEL CAP | Lockable |

| ELECTRICAL SYSTEM | |
|-------------------|---|
| TYPE | 24 volt |
| ALTERNATOR | 60 amp |
| STARTER MOTOR | 24V-7.0kW output |
| BATTERY | 2 x N120, (660 CCA) connected in series |

| CABIN GENERAL FEATURES | |
|--------------------------|---|
| STEPS | Three heavy duty anti-slip steps |
| DOORS | Drivers: 88 ° & passengers 70 ° opening internally reinforced doors |
| MIRRORS | Door mounted 22" main & convex mirrors heated & power adjustable |
| WIPERS | Two speed windscreen wipers with variable intermittent wipe mode |
| EXTERIOR LIGHTING | Adaptive driving beam (ADB), LED automated headlights with wash function & automated rear LED combination lamps. Roof mounted clearance lamps Front LED fog lamps |
| AUDIBLE WARNING | Reverse alarm |
| GRILLE | Chrome finish |
| SECURITY | Central locking with keyless entry and engine immobiliser |

| INSTRUMENTATION | |
|----------------------------------|--|
| MULTI INFORMATION DISPLAY | AEB, FCW, DWS, LDW, ADB, HSA (MT only), ACC (AMT only), TMW, EBS, ESC Low fuel, water separator, low coolant, AdBlue warnings, speed limit, engine overheat, ASR, low voltage, charging, engine oil pressure, cab tilt, low air pressure, parking brake, AMT-warnings, VAT system, radar, cruise control, weave warning, maintenance display, fuel economy advice |
| GENERAL INSTRUMENTATION | Speedometer, Tachometer, air pressure, coolant temp & AdBlue gauges Hour meter, odometer / trip meter |

CABIN INTERIOR

| | |
|---------------------------|---|
| SEATING | Driver: ISRINGHAUSEN 6860 with arm rest (AMT only) Integrated seatbelt with pre-tensioner, shoulder adjustment, heater/ventilation, lumbar support, firmness adjustment, seat cushion tilt, lowering, horizontal position & height adjustment |
| | Passenger: Fixed bucket with reclining adjustment |
| SEATBELTS | 3-point type on drivers & passenger seats |
| STEERING COLUMN | Adjustable up/down & forward/backward tilt |
| ENTRY ASSIST GRIPS | Driver & passenger large assist hand grip with a sill plate grip. Driver's step light |
| DOOR WINDOWS | Electrically operated |
| STORAGE | Centre storage console Two overhead storage lockers Dual cup holders |
| POWER OUTLET | Two 24V USB outlets & one 24V socket |
| AIRCONDITIONING | Auto control |
| INTERIOR LIGHTING | LED interior lighting |



AUDIO VISUAL UNIT

| | |
|----------------------------------|--|
| SCREEN TYPE | 6.2" LCD with capacitive touch |
| OPERATING SYSTEM | Android |
| RADIO | AM/FM/DAB+ Internet radio via smart phone |
| INTERNAL STORAGE CAPACITY | 32GB |
| OTHER CAPABILITY | Provision for external camera inputs, navigation, reverse sensors and tyre pressure monitoring |

DRIVER CONTROLS

| | |
|---------------------------|--|
| SAFETY SYSTEMS | AEB off, LDW & ACC on/off, FCW & ACC distance setting, ESC off, head lamps & ALS on/off HSA on/off switch (MT only) |
| ENGINE | Idle speed control Cruise control |
| TRANSMISSION (AMT) | Auto/Manual, Econo, Smart Glide off, shift down retarder over ride & skip shift switches |
| GENERAL CONTROLS | Exhaust brake & retarder controls, windscreen/washer switch, horn, remote mirror switches, super kick drive switch & inter-axle lock |



AMT model shown

| WEIGHTS (kg) | | | | | | | |
|--------------|----------|--------|----------------------------|--------|----------------------|-------|-------|
| MODELS | RATINGS* | | LOADING LIMIT* (at ground) | | CAB CHASSIS WEIGHT # | | |
| | GVM | GCM | FRONT | REAR | FRONT | REAR | TOTAL |
| CYJ 530 AMT | 29,000 | 55,000 | 11,000 | 15,000 | 5,740 | 3,014 | 8,754 |
| CYJ 530 | 29,000 | 55,000 | 11,000 | 15,000 | 5,666 | 3,026 | 8,692 |

* Vehicle ratings and axle weight limits are subject to government regulatory requirements and weight distribution analysis. Consult your Isuzu dealer to select the correct vehicle for your specific application.

Cab chassis only as supplied and including 10 litres of fuel.

| DIMENSIONS (mm) | | | | | | | | | | | (m) |
|-----------------|-------|-------|-------|-------|-------|-------|------------|--------------------|-----------------|---------------|-----------------------------|
| MODELS | WB | OAL | FOH | ROH | EA | CE | REAR TRACK | OUTSIDE REAR TRACK | CH (calculated) | RFH (unladen) | TURNING CIRCLE kerb to kerb |
| CYJ 530 AMT | 5,980 | 9,580 | 1,370 | 1,575 | 5,964 | 7,539 | 1,870 | 2,485 | 3,085 | TBA | 20 |
| CYJ 530 | 5,980 | 9,580 | 1,370 | 1,575 | 5,964 | 7,539 | 1,870 | 2,485 | 3,085 | TBA | 20 |

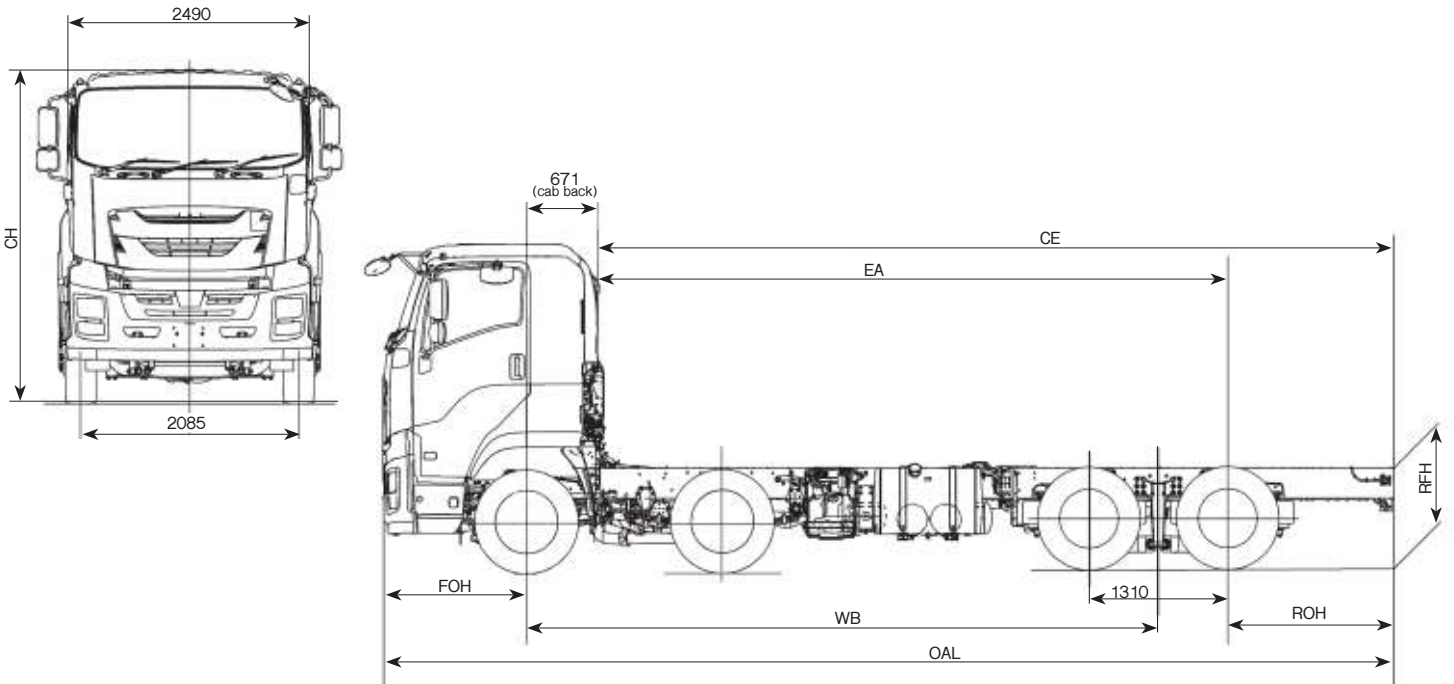

| PERFORMANCE (calculated - typical paved road) | | | | |
|---|------------------|---|---|------------------------------------|
| MODELS | At 29,000 kg GVM | GEARED SPEED* (top gear at peak power engine rpm) | LOW SPEED GRADEABILITY (lowest forward gear assuming no wheel slip) | ENGINE SPEED (top gear at 90 km/h) |
| CYJ 530 AMT | At 29,000 kg GVM | 96 km/h @ 1,800 rpm | 87% | 1,683 rpm |
| CYJ 530 | At 29,000 kg GVM | 107 km/h @ 1,800 rpm | 90% | 1,517 rpm |

* Maximum speed achievable depends on vehicle frontal area as well as other factors. Consult your Isuzu dealer for more detailed information.

| ORDER CODES | |
|-------------|--------|
| MODELS | CODES |
| CYJ 530 AMT | CJ0315 |
| CYJ 530 | CJ0515 |

#Total 5 Year Warranty, including Base Warranty (36 months / 250,000kms) and Additional Warranty (24 months / 250,000kms), cover is 60 months or 500,000kms, whichever comes first. To qualify for Additional Warranty, all scheduled servicing during the Base and Additional Warranty periods (ie. the total 60 months) must be performed by an authorised Isuzu service dealer from the date of delivery to the first customer. If scheduled servicing is performed by unauthorized service providers, only the Base Warranty will apply.

The information in this spec sheet was correct at time of printing, but all measurements, specifications and equipment are subject to change without notice. Some equipment may have been changed and/or is available at extra cost. Isuzu New Zealand (INZ) may make changes at any time without notice, in prices, colours, materials, equipment and models. INZ makes all reasonable attempts to ensure the availability of all vehicles and equipment. The information in this spec sheet is general in nature. Your Isuzu dealer can confirm all measurements, specifications and vehicle / equipment availability upon request. To the extent permitted by the law, INZ is not liable to any person as result of reliance on the content of this spec sheet.