

EXY 460



Chrome appearance grille available on 530 models only
Vehicle shown not representative of EXY 460

WEIGHT RATINGS

GVM	24,000 kg
GCM	55,000 kg

ENGINE

POWER	338 kW (460PS) @ 1,800 rpm (DIN NET)
TORQUE	2,256 Nm @ 900 - 1,300 rpm (DIN NET)

TRANSMISSION

18 speed manual transmission (MT)
16 speed automated manual transmission (AMT)

* Refer to back page for detailed weight rating information

INTELLIGENT SAFETY		
ACTIVE SAFETY ADVANCED DRIVER ASSISTANCE SYSTEMS (ADAS)	Advanced Emergency Brake System	(AEB)
	Adaptive Cruise Control (AMT only)	(ACC)
	Adaptive Driving Beam headlights	(ADB)
	Anti Skid Regulator	(ASR)
	Anti Lock Braking System	(ABS)
	Automatic Lighting System	(ALS)
	Distance Warning System	(DWS)
	Electronic Brake System	(EBS)
	Electronic Stability Control	(ESC)
	Forward Collision Warning	(FCW)
	Hill Start Aid	(HSA)
	Lane Departure Warning	(LDW)
Traffic Movement Warning	(TMW)	
Vehicle Assistance Technology	(VAT)	
PASSIVE SAFETY CABIN OCCUPANT SAFETY SYSTEMS (COSS)	Drivers side airbag & seatbelt pretensioner, multi-function steering wheel controls, Internally reinforced doors	

ISUZU WARRANTY COVER	
WARRANTY	5 Year / 500,000 km Warranty*

ENGINE	
DESCRIPTION	Isuzu 6WG1 - TCC
TYPE	6 cylinder 24 valve SOHC
DISPLACEMENT	15,681 cc
BORE X STROKE	147mm x 154mm
POWER	338 kW (460PS) @ 1,800 rpm (DIN NET)
TORQUE	2,256 Nm @ 900 - 1,300 rpm (DIN NET)
INDUCTION	Electronically controlled variable nozzle turbocharger with air-to-air intercooler
FUEL INJECTION	Direct injection high pressure common rail
EMISSION CONTROL	Selective Catalytic Reduction (SCR). Euro V compliant

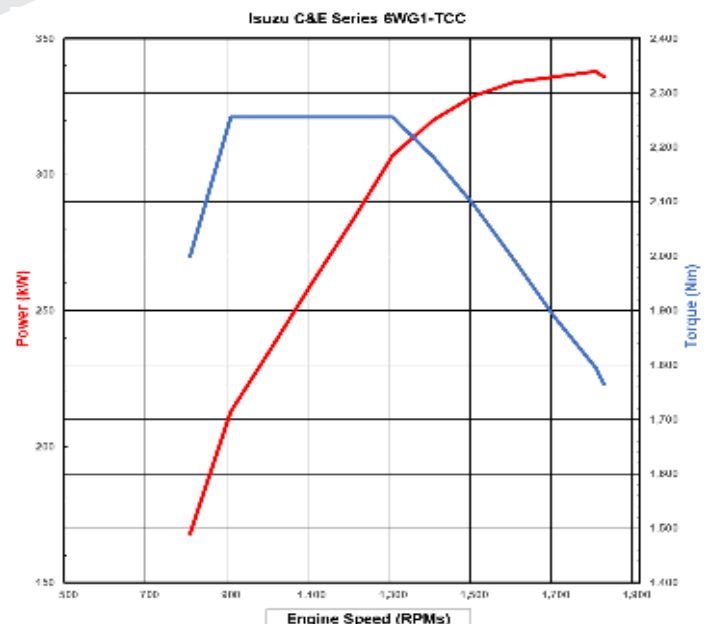

CLUTCH	
MT	Type: Eaton twin plate with clutch brake
	Clutch Plate Diameter: 394mm (15.5")
AMT	Type: Diaphragm twin plate pull type
	Clutch Plate Diameter: 394mm (15.5")

TRANSMISSION	
MT	Description: Eaton RTL018918B
	Type: 18 speed manual constant mesh
	Ratios:
	1ST 14.40
	2ND 12.29
	3RD 8.56
	4TH 7.30
	5TH 6.05
	6TH 5.15
	7TH 4.38
8TH 3.74	
9TH 3.20	
10TH 2.73	
11TH 2.29	
12TH 1.92	
13TH 1.62	
14TH 1.38	
15TH 1.17	
16TH 1.00	
17TH 0.86	
18TH 0.73	
Reverse: L/L 15.05, L/H 12.86, H/L 4.03, H/H 3.43	
Power Take Off facility: Provision on bottom & RHS transmission case	
AMT	Description: Isuzu MJX16
	Type: 16 speed Automated Manual synchromesh
	Ratios:
	1ST 14.01
	2ND 11.34
	3RD 9.93
	4TH 8.03
	5TH 6.84
	6TH 5.53
	7TH 4.58
8TH 3.71	
9TH 3.05	
10TH 2.47	
11TH 2.16	
12TH 1.75	
13TH 1.49	
14TH 1.20	
15TH 1.00	
16TH 0.81	
REV1 12.58	
REV2 10.18	
Power Take Off facility: Provision on LHS of transmission case	

AXLES	
FRONT	Description: Isuzu F075
	Type: Reverse Elliot I-beam
	Capacity: 7,500 kg
REAR	Description: Isuzu RT210
	Type: Hypoid tandem drive with inter-axle lock
	Capacity: 21,000 kg
	Ratio: 3.90:1

SUSPENSION	
FRONT	Tapered parabolic leaf springs with double acting shock absorbers & stabiliser bar
REAR	Isuzu 8-bag air suspension with stabilizer bars & hydraulic shock absorbers on both axles

BRAKES	
TYPE	Dual circuit drum brake system featuring:
	- Electronic Brake System (EBS)
	- Electronic Stability Control (ESC)
	- Hill Start Assist (HSA)
	- Advanced Emergency Brake System (AEB)
DIAMETER FRONT	410mm x 160mm
DIAMETER REAR	410mm x 220mm
PARK BRAKE	Spring operated on rear axles
AUXILIARY BRAKE	Isuzu air operated exhaust brake Isuzu magnetic driveshaft retarder

STEERING	
TYPE	Recirculating ball with integral power assistance
WHEEL LOCK ANGLE	Inner 45° / Outer 35°

WHEELS & TYRES	
FRONT	Wheels: 22.5" x 8.25" 165mm offset, Alcoa disc
	Tyres: 275/70R22.5 148/145
	Max tyre rating: 6,300 kg
REAR	Wheels: 22.5" x 8.25" 165mm offset, Alcoa alloy disc
	Tyres: 275/70R22.5 148/145
	Max tyre rating: 23,200 kg

CHASSIS FRAME	
TYPE	Rolled steel channel. Cold riveted ladder frame HT540 weldable steel
DIMENSIONS	285mm x 85mm x 7mm

FUEL TANK & ADBLUE TANK	
TYPE	Frame mounted alloy fuel tank LHS. Frame mounted AdBlue tank LHS
CAPACITY	Diesel = 400L / AdBlue = 75L
FUEL CAP	Lockable

ELECTRICAL SYSTEM	
TYPE	24 volt
ALTERNATOR	60 amp
STARTER MOTOR	24V-7.0kW output
BATTERY	2 x N120, (660 CCA) connected in series

CABIN GENERAL FEATURES	
STEPS	Three heavy duty anti-slip steps
DOORS	Drivers: 88° & passengers: 70° opening internally reinforced doors
MIRRORS	Door mounted 22" main & convex mirrors heated & power adjustable
WIPERS	Two speed windscreen wipers with variable intermittent wipe mode
EXTERIOR LIGHTING	Adaptive driving beam (ADB), LED automated headlights with wash function & automated rear combination lamps Roof mounted clearance lamps Front LED fog lamps
AUDIBLE WARNING	Reverse alarm
GRILLE	Painted cab colour
SECURITY	Central locking with keyless entry and engine immobiliser

INSTRUMENTATION	
MULTI INFORMATION DISPLAY	AEB, FCW, DWS, LDW, ADB, HSA, ACC (AMT only), TMW, EBS, ESC Low fuel, water separator, low coolant, AdBlue warnings, speed limit, engine overheat, ASR, low voltage, charging, engine oil pressure, cab tilt, low air pressure, parking brake, AMT-warnings, VAT system, radar, cruise control, weave warning, maintenance display, fuel economy advice.
GENERAL INSTRUMENTATION	Speedometer, Tachometer, air pressure, coolant temp & AdBlue gauges Hour meter, odometer / trip meter

CABIN INTERIOR

SEATING	Driver: ISRINGHAUSEN 6860 with arm rest (AMT only) Integrated seatbelt with pre-tensioner, shoulder adjustment, heater/ventilation, lumbar support, firmness adjustment, seat cushion tilt, lowering, horizontal position & height adjustment
	Passenger: Fixed bucket with reclining adjustment
SEATBELTS	3-point type on drivers & passenger seats
STEERING COLUMN	Adjustable up/down & forward/backward tilt
ENTRY ASSIST GRIPS	Driver & passenger large assist hand grip with a sill plate grip. Driver's step light
DOOR WINDOWS	Electrically operated
STORAGE	Centre storage console Two overhead storage lockers Dual cup holders
POWER OUTLET	Two 5V 2.4 amp USB outlets & one 24V socket
AIRCONDITIONING	Auto control
INTERIOR LIGHTING	LED interior lighting



AUDIO VISUAL UNIT

SCREEN TYPE	6.2" LCD with capacitive touch
OPERATING SYSTEM	Android
RADIO	AM/FM/DAB+ Internet radio via smart phone
INTERNAL STORAGE CAPACITY	32GB
OTHER CAPABILITY	Provision for external camera inputs, navigation, reverse sensors and tyre pressure monitoring

DRIVER CONTROLS

SAFETY SYSTEMS	AEB off, LDW & ACC on/off, FCW & ACC distance setting, ESC off, head lamps & ALS on/off HSA on/off switch
ENGINE	Idle speed control Cruise control
TRANSMISSION (AMT)	Auto/Manual, Econo, Smart Glide off, shift down retarder over ride & skip shift switches
GENERAL CONTROLS	Exhaust brake & retarder controls, windscreen/washer switch, horn, remote mirror switches, super kick drive switch & inter-axle lock



AMT model shown

WEIGHTS (kg)							
MODELS	RATINGS*		LOADING LIMIT* (at ground)		CAB CHASSIS WEIGHT #		
	GVM	GCM	FRONT	REAR	FRONT	REAR	TOTAL
EXY 460 AMT	24,000	55,000	6,000	15,000	4,494	3,240	7,734
EXY 460	24,000	55,000	6,000	15,000	4,775	3,415	8,190

* Vehicle ratings and axle weight limits are subject to government regulatory requirements and weight distribution analysis. Consult your Isuzu dealer to select the correct vehicle for your specific application.

Cab chassis only as supplied and including 10 litres of fuel.

DIMENSIONS (mm)											(m)
MODELS	WB	OAL	FOH	ROH	EA	CE	REAR TRACK	OUTSIDE REAR TRACK	CH (calculated)	RFH (unladen)	TURNING CIRCLE kerb to kerb
EXY 460 AMT	4,300	7,190	1,370	865	4,284	5,149	1,870	2,485	3,059	940	15
EXY 460	4,300	7,190	1,370	865	4,284	5,149	1,870	2,485	3,059	940	15

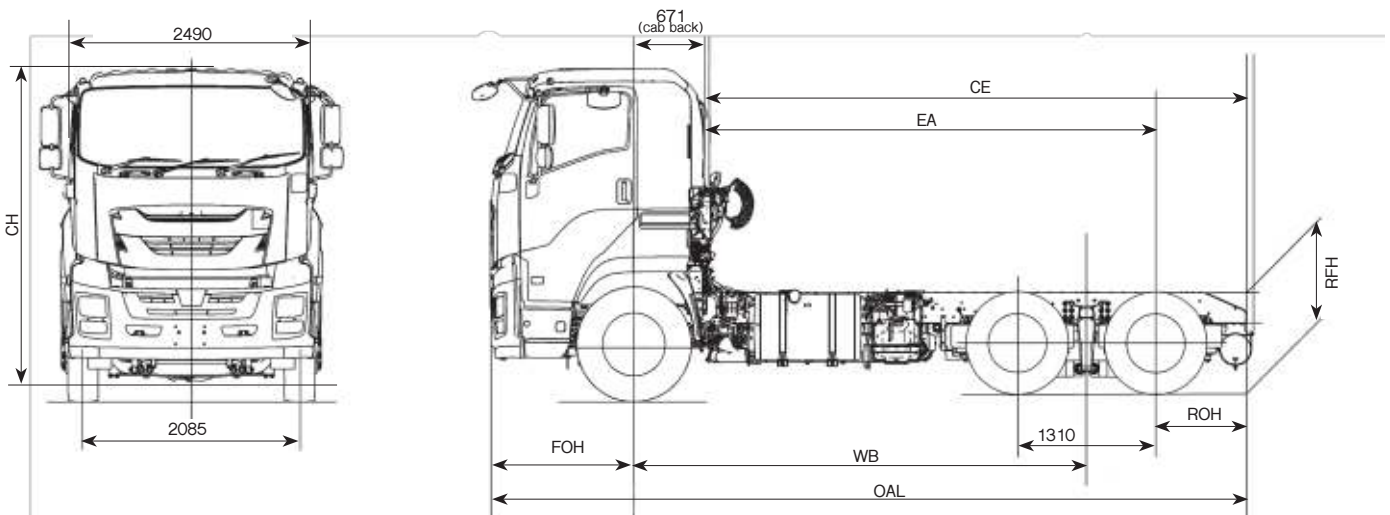

PERFORMANCE (calculated - typical paved road)				
		GEARED SPEED* (top gear at peak power engine rpm)	LOW SPEED GRADEABILITY (lowest forward gear assuming no wheel slip)	ENGINE SPEED (top gear at 90 km/h)
EXY 460 AMT	At 24,000 kg GVM	101 km/h @ 1,800 rpm	101%	1,602 rpm
EXY 460	At 24,000 Kg GVM	112 km/h @ 1,800 rpm	103%	1,443 rpm

* Maximum speed achievable depends on vehicle frontal area as well as other factors. Consult your Isuzu dealer for more detailed information.

ORDER CODES	
MODELS	CODES
EXY 460 AMT	EX0115
EXY 460	EX0215

#Total 5 Year Warranty, including Base Warranty (36 months / 250,000kms) and Additional Warranty (24 months / 250,000kms), cover is 60 months or 500,000kms, whichever comes first. To qualify for Additional Warranty, all scheduled servicing during the Base and Additional Warranty periods (ie. the total 60 months) must be performed by an authorised Isuzu service dealer from the date of delivery to the first customer. If scheduled servicing is performed by unauthorized service providers, only the Base Warranty will apply.

The information in this spec sheet was correct at time of printing, but all measurements, specifications and equipment are subject to change without notice. Some equipment may have been changed and/or is available at extra cost. Isuzu New Zealand (INZ) may make changes at any time without notice, in prices, colours, materials, equipment and models. INZ makes all reasonable attempts to ensure the availability of all vehicles and equipment. The information in this spec sheet is general in nature. Your Isuzu dealer can confirm all measurements, specifications and vehicle / equipment availability upon request. To the extent permitted by the law, INZ is not liable to any person as result of reliance on the content of this spec sheet.