



# I4CR IMPACT CRUSHER

The McCloskey® I4CR compact recirculating impact crusher combines mobility, power and new features to deliver the highest production across applications and materials.

## FEATURES

- ✓ Powerful 1050mm (41.3") diameter x 1125mm (44.3") wide Impactor
- ✓ Aggressive Blow Bar design with larger contact area for high capacity crushing
- ✓ Asymmetric Feeder integrated into single feeder/hopper configuration
- ✓ Tough-Flex® heavy duty conveyor belt delivers lasting performance
- ✓ Chamber Safety Arm for secure access to impact chamber
- ✓ Simplified Hydraulics and Direct Drive Crusher
- ✓ Efficient and simple operation



The I4CR combines the heavy duty impact crushing of the I4C with the versatility of a recirculation system to combine the productivity of an 1125mm (44.3") impactor with screening efficiency - all in a compact and highly mobile footprint for maximum power and maneuverability. The radial conveyor can swing out for additional stockpiling. Like the I4C, the crusher's design has ease of access in mind, with an excellent layout for operation, maintenance and service.

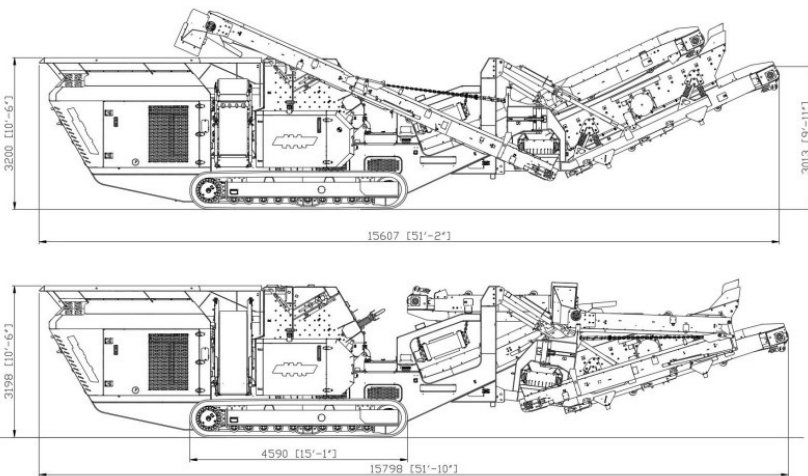

## I4CR TECH SPECS

<b>Engine</b>	280kW (375 Hp)
<b>Rotor Diameter</b>	1050mm (41.3")
<b>Rotor Width</b>	1125mm (44.3")
<b>Screenbox</b>	3660mm x 1525mm (12' x 5')
<b>Grizzly Feeder</b>	
Width	1060mm (41.7")
Length	4250mm (167.3")
<b>Hopper</b>	
Width	2150mm (84.6")
Length	4775mm (188")
<b>Stockpile Heights</b>	
Main Conveyor	3753mm (12' 4")
Side Conveyor	2758mm (9' 1")
Fines Conveyor	3013mm (9' 11")

## TRANSPORT

<b>Transport Height</b>	3.2m (10' 6")
<b>Transport Length</b>	15.798m (51' 10")
<b>Transport Width</b>	3.0m (9' 10")
<b>Weight</b>	40,880 kg (90,125 lbs)

## OPTIONS

4 Full Height Blow Bars | Grizzly Blanking Plates | Feeder Punch Plate | Hoist | Various Blow Bar Options | Main Conveyor Variable Speed | Work lights | Refueling Pump | Water Pump and Dust Suppression