

ZAXIS-7G series

HITACHI

Reliable Solutions

ZAXIS350

Hitachi Construction Machinery Group

LANDCROS

Japanese Excellence—Reliable Solutions



HYDRAULIC EXCAVATOR

Model code	: ZX350LC-7G	ZX350LCH-7G
Engine rated power	: 200 kW (268HP)	200 kW (268HP)
Operating weight	: 31 900 - 34 100 kg	34 800 kg
Bucket capacity	: 1.38 - 1.86 m ³	1.38 - 1.4 m ³



GET MORE FROM YOUR MACHINE

You're at the heart of Hitachi Construction Machinery's design for its latest range of excavators. To continuously improve on previous generation machines, we've focused on enhancing your profit in business.

We have made cost reduction for our customers our top priority and, in doing so, have achieved reduced fuel consumption. The cab has been redesigned to improve the operator's working environment and controllability, with production also expected to improve. An engine that already has a proven track record of high reliability has been adopted, and we have placed further work in it to make it even more robust.



INSIDE



4-5 | MORE FUEL EFFICIENCY



6-7 | BETTER OPERABILITY



8-9 | HIGH DURABILITY AND RELIABILITY



10-11 | SMOOTH MAINTENANCE



12-13 | MACHINE MANAGEMENT

MORE FUEL EFFICIENCY

Improved HIOSIII hydraulic system matched with a new engine improves the ZX-7G fuel efficiency and fuel cost.

Reducing fuel consumption

With the reduction of fuel consumption in each mode compared to conventional models, the new model will contribute to increasing your profit.

HIOS III hydraulic system

The hydraulic system developed was based on the concept of a hydraulic system that fits in-line with a sense of human operation.

- ✓ Efficient hydraulic control achieves smoother and more speedy movement of front attachments.

Fine-tuned hydraulic pump control

A solenoid valve mounted on the hydraulic system further controls the pump flow rate to reduce unnecessary load on the engine.

- ✓ Contributing to low fuel consumption operation

High efficiency engine

A common rail type fuel injection system is used to electronically control fuel quantity and injection timing for more efficiency in fuel combustion.

- ✓ Contributing to high engine power and low fuel consumption.

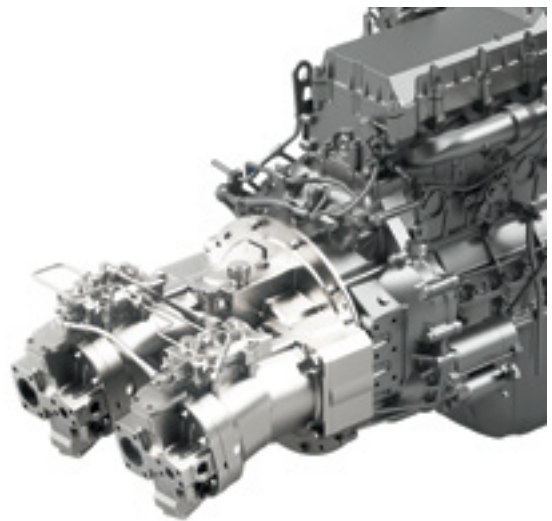

Operation support system for high efficiency

ECO gauge

A gauge displays the current fuel consumption during an operation with a higher mark on the gauge indicating a lower fuel usage. The eco-gauge helps to support the operator in achieving lower fuel consumption throughout the work required.

ECO guidance

Prompts the operator to better fuel economy. Messages are also shown while the ECO gauge is displayed.

- ✓ Prompts operator for better economy

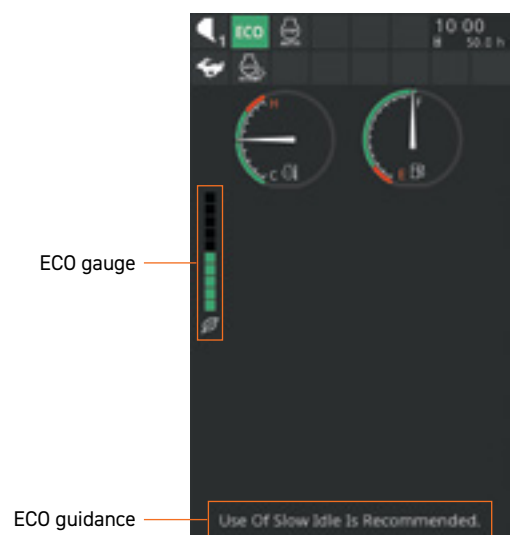



BETTER OPERABILITY

In the cab of the ZAXIS-7G, enhanced comfort and safety features are at your fingertips, offering the power to perform greater productivity with ease as well as reduced fatigue.



Operation is easy with ergonomically designed controls and switches.



Low-reflective color 8" monitor, 42% larger display compared to ZX-5G series. Easier to view and navigate. Bluetooth® and optional USB power supply available.



New designed pilot shut-off lever
The newly designed pilot shut-off lever allows easier locking and unlocking with wrist operation.



AERIAL ANGLE
270-degree bird's eye-view camera system.

HIGH DURABILITY AND RELIABILITY

Completing a project on time and on budget depends on the ability of your construction equipment to perform all day, every day. That's why the owners have profited from generations of reliable and durable machinery. Hitachi Construction Machinery develops its machines with constant awareness of the need to further improve long-term reliability. High long-term reliability is good in not only performance all day, every day but also for resale value.

An engine with improved reliability

The engine is a highly reliable model that has already been adopted previously. In adopting it for the ZX-7G, we have put in our efforts to further increase durability and to boost your uptime. EGR (Exhaust Gas Recirculation) is removed from the engine, increasing its durability for using low-quality fuel.

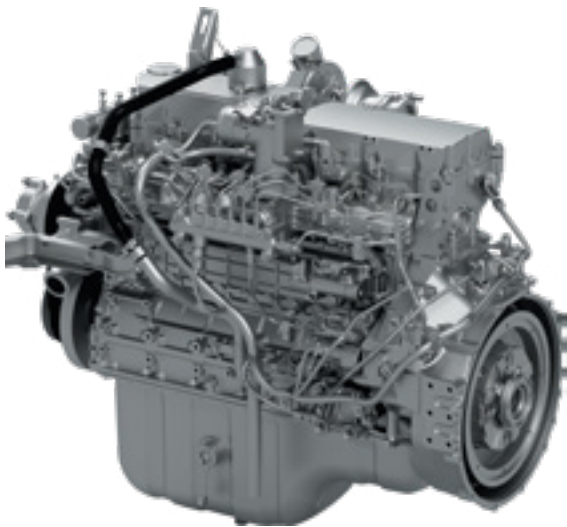

✓ Reinforced motor cover

Enlarged track guard

✓ Reducing wear and damage risks on the track link and lower roller.

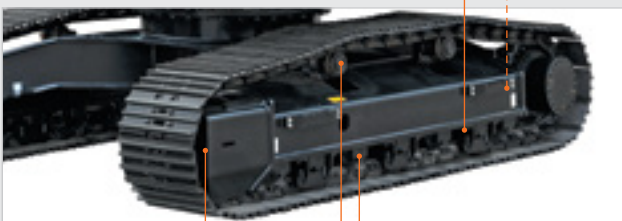

Structurally improved upper roller, lower roller, and the front idler

✓ Maintains lubrication performance in the roller and improves roller durability



Heavy-Duty model ZAXIS 350LCH

The heavy duty model is more durable with reinforced load-bearing points on the excavator

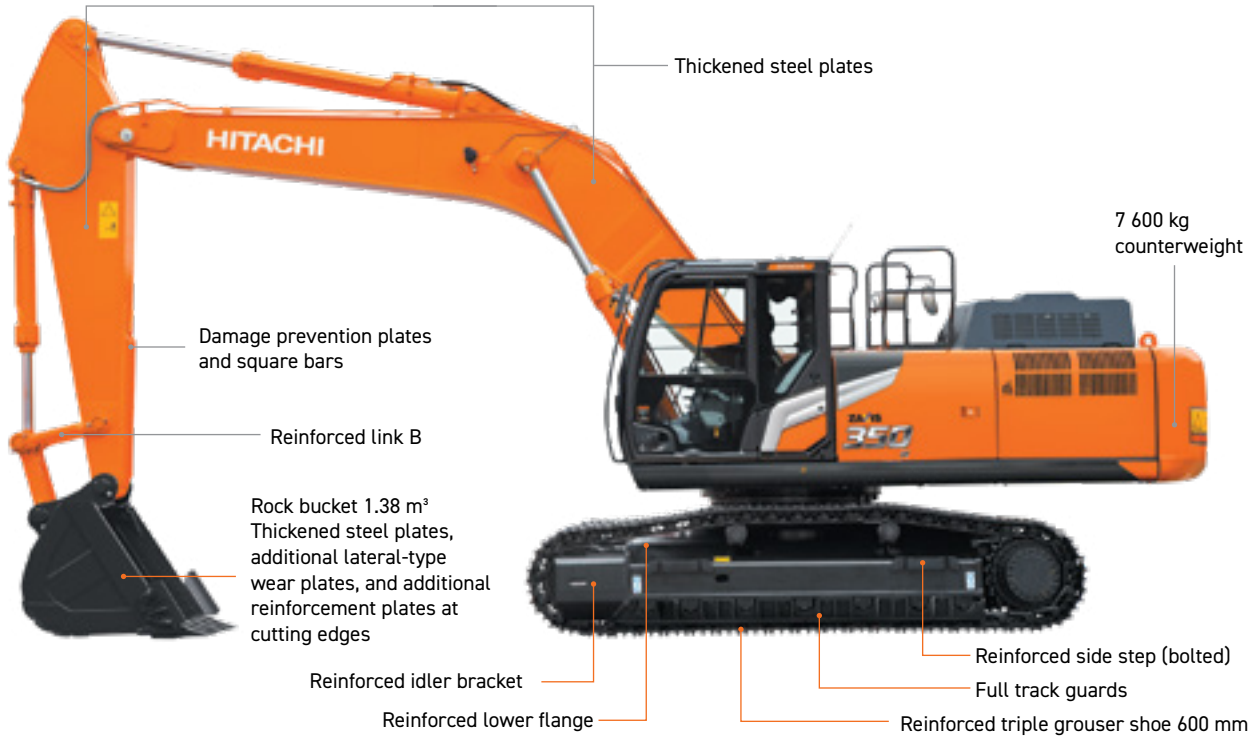

High reliable fuel circuit

Larger fuel pump and changing filter locaton improve the reliability of the entire fuel circuit and further help to prevent engine problems. Contributing to boost your uptime.

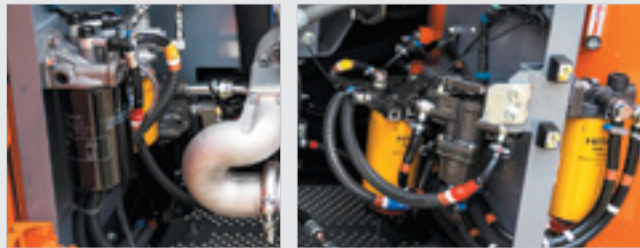

Reinforced platform plate

- ✓ Increased plate strength and deformation-resistant structure



Equipped with an expansion tank

- ✓ Improving the reliability of the engine cooling performance



SMOOTH MAINTENANCE

Regular maintenance is essential for the machine to achieve high performance.

ZAXIS excavators are designed for ease of regular maintenance. Simple and easy maintenance keeps the machine in good condition and keeps its high performance.

Easy to clean radiator/Oil cooler/Inter cooler core



Dust-proof indoor net

- ✓ Provided at the front of radiator
- ✓ Easy to be removed and cleaned



Cleaning port for radiator/Oil cooler/Inter cooler core

- ✓ The cover can be opened without the need for any tools
- ✓ Easy to clean radiator/Oil cooler/Inter cooler core with simple air blowing



Easy-access air conditioner condenser

- ✓ The condenser can be opened
- ✓ Easy to clean radiator/Oil cooler/Inter cooler core with simple air blowing

Remote lubrication of arm-end pin

- ✓ Reducing the risk of mud stuck in the lubrication port
- ✓ Performs smooth lubrication



Easy access to filters

Filter locations are concentrated in the pump room

- 1 Fuel main filter
- 2 Fuel pre-filter with water separator
- 3 Engine oil filter
- 4 Pilot filter

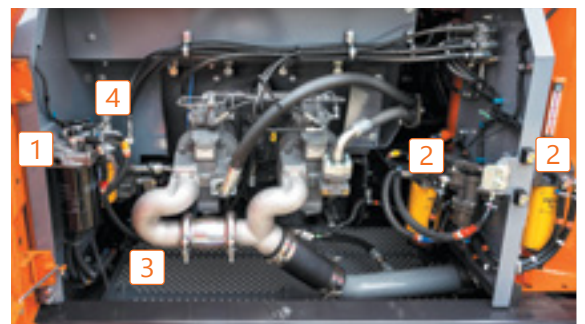



Handrail

Handrails have been installed on the platform to allow safer access to the engine and maintenance work around the engine



MACHINE MANAGEMENT

Hitachi Construction Machinery offers a wide range of after-sales services to help you feel in total control of your fleet and workload. These initiatives give you access to vital data and tools to manage your machine.



ConSite
Consolidated Solution for Construction Sites



A wide range of data on Global e-Service enhances efficiency.

Data report

Regular reports inform you of the machine's operation status. Emergency reports inform you of alarm information.

The stable operation of the machine is further supported with two types of reports visualizing the machine's daily operation status.

Monthly report

Regular reports on the operating status of each machine.

Alarm report

If an emergency alarm is generated from a sensor mounted on the machine, its alarm content is reported by e-mail in a timely manner. You can receive it on your computer, mobile phone, or smartphone (communication format is via e-mail).

movie for
further info.





ConSite Pocket

ConSite Pocket sends you real-time alerts for issues arising with your machine. You'll receive recommendations on what to do and step-by-step help guides. The app also enables you to see the location of your fleet.

- Use your smartphone to check monthly reports, alarm reports, as well as machine operating positions.
- If an alarm report is generated, the system will notify you immediately using a push notification.

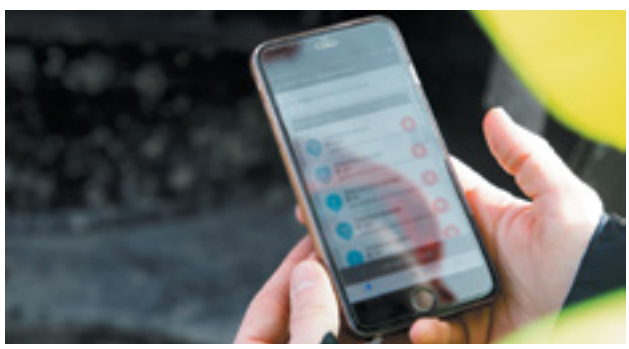

Monthly report



Machine finder

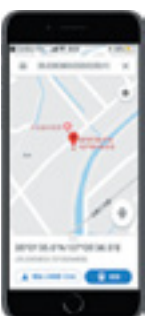

Location information

movie for further info.

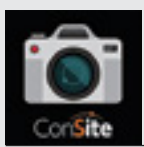

ConSite Shot

This is a smartphone application that allows you to easily perform daily inspections of your machines and rental warehousing / delivery management.

- You can easily create high-quality inspection reports and share information within your company or with agents etc.
- Customers who have rental machines can also use it during rental warehousing / delivery inspections.



Load condition



Acceptance or delivery inspection of rental machines



Inspection report with condition photo

movie for further info.



ConSite OIL

This system detects if the oil quality has deteriorated, due to contamination or low viscosity. If this happens, you and your authorized dealer will receive an alert.

movie for further info.



SPECIFICATIONS

ENGINE	
Model	Isuzu AE-6HK1XWSA
Type	4-cycle water-cooled, common rail direct injection
Aspiration	Turbocharged, intercooled
No. of cylinders	6
Rated power	
ISO 14396 : 2002 gross	200 kW (268HP) at 1 900 min ⁻¹ (rpm)
ISO 9249 : 2007 net	190 kW (254HP) at 1 900 min ⁻¹ (rpm)
Maximum torque	1 069 Nm (109 kgfm) at 1 500 min ⁻¹ (rpm)
Piston displacement	7.790 L
Bore and stroke	115 mm x 125 mm
Batteries	2 x 12 V

HYDRAULIC SYSTEM			
Hydraulic Pumps			
Main pumps	2 variable displacement axial piston pumps		
Maximum oil flow	2 x 288 L/min		
Pilot pump	1 gear pump		
Maximum oil flow	30.2 L/min		
Hydraulic Motors			
Travel	2 variable displacement axial piston motors		
Swing	1 axial piston motor		
Relief Valve Settings			
Implement circuit	34.3 MPa (350 kgf/cm ²)		
Swing circuit	32.4 MPa (330 kgf/cm ²)		
Travel circuit	34.3 MPa (350 kgf/cm ²)		
Pilot circuit	3.9 MPa (40 kgf/cm ²)		
Power boost	38.0 MPa (338 kgf/cm ²)		
Hydraulic Cylinders			
	Quantity	Bore	Rod diameter
Boom	2	145 mm	100 mm
Arm	1	170 mm	115 mm
Bucket	1	140 mm	95 mm

UPPERSTRUCTURE	
Revolving Frame	
D-section frame for resistance to deformation.	
Swing Device	
Axial piston motor with planetary reduction gear is bathed in oil. Swing circle is single-row. Swing parking brake is spring-set/hydraulic released disc type.	
Swing speed	10.7 min ⁻¹ (rpm)
Swing torque	120 kNm (12 200 kgfm)

UNDERCARRIAGE	
Tracks	
Heat-treated connecting pins with dirt seals. Hydraulic (grease) track adjusters with shock-absorbing recoil springs.	
Numbers of Rollers and Shoes on Each Side	
Upper rollers	2
Lower rollers	8 : ZX350LC-7G / ZX350LCH-7G
Track shoes	48 : ZX350LC-7G / ZX350LCH-7G
Track guards	3 : ZX350LC-7G
	Full track guard : ZX350LCH-7G
Travel Device	
Each track driven by 2-speed axial piston motor. Parking brake is spring-set/hydraulic-released disc type. Automatic transmission system: High-Low.	
Travel speeds	High : 0 to 5.0 km/h
	Low : 0 to 3.2 km/h
Maximum traction force	298 kN (30 400 kgf)
Gradeability	70% (35 degree) continuous

SERVICE REFILL CAPACITIES	
Fuel tank	630.0 L
Engine coolant	41.0 L
Engine oil	41.0 L
Swing device	15.7 L
Travel device (each side)	11.0 L
Hydraulic system	340.0 L
Hydraulic oil tank	180.0 L

WEIGHTS AND GROUND PRESSURE

Operating Weight and Ground Pressure

			ZX350LC-7G ^{*1}		
Boom type			Monoblock		
Shoe type	Shoe width (mm)	Arm length (m)	kg	kPa	kgf/cm ²
Triple grouser	600	2.67	33 100	62	0.63
		3.20	33 200	62	0.63
		4.00	33 400	62	0.64
	700	2.67	33 700	54	0.55
		3.20	33 700	54	0.55
		4.00	33 900	54	0.55
	800	2.67	34 100	48	0.49
		3.20	34 100	48	0.49
		4.00	34 300	48	0.49
Reinforced Triple grouser	600	2.67	33 300	62	0.63
		3.20	33 400	62	0.64
		4.00	33 500	63	0.64

*1 Including 1.40 m³ (ISO 7451 : 2007 heaped) bucket weight (1 170 kg) and counterweight (6 900 kg).

Operating Weight and Ground Pressure

			ZX350LCH-7G ^{*2}		
Boom type			Monoblock		
Shoe type	Shoe width (mm)	Arm length (m)	kg	kPa	kgf/cm ²
Reinforced Triple grouser	600	2.67	35 400	66	0.67
	600	3.20	35 500	66	0.68

*2 Including 1.38 m³ (ISO 7451 : 2007 heaped) H-bucket weight (1 340kg) and counterweight (7 600kg).

BASIC MACHINE WEIGHT AND COMPONENTS WEIGHT

Basic Machine Weight and Overall Width

Excluding front end attachment, fuel, hydraulic oil and coolant etc. Including counterweight.

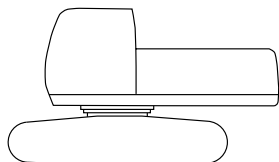

ZX350LC-7G		
Shoe width (mm)	Weight (kg)	Overall width (mm)
600	25 600	3 190
700	26 200	3 290
800	26 600	3 390

ZX350LCH-7G		
Shoe width (mm)	Weight (kg)	Overall width (mm)
600	27 200	3 190

Components Weight

Unit: kg

	ZX350LC-7G	ZX350LCH-7G
Counterweight	6 900	7 600
Monoblock boom (with arm cylinder and boom cylinder)	3 700	4 000
Arm 2.67 m (with bucket cylinder)	1 700	1 900
Arm 3.20 m (with bucket cylinder)	1 800	2 000
Arm 4.00 m (with bucket cylinder)	2 000	2 000
Bucket ISO 7451 : 2007 1.40 m ³	1 200	1 200
Bucket ISO 7451 : 2007 1.38 m ³	-	1 300

BUCKET AND ARM DIGGING FORCE

Arm length	2.67 m		3.20 m		4.00 m	
	kN	kgf	kN	kgf	kN	kgf
Bucket digging force ISO 6015 : 2006	246	25 100	246	25 100	246	25 100
Arm crowd force ISO 6015 : 2006	222	22 600	185	18 900	158	16 100

At power boost

SPECIFICATIONS

BACKHOE ATTACHMENTS

ZX350LC-7G

Bucket	Capacity (m ³)	Width (mm)		No. of teeth	Weight (kg)	Recommendation		
	ISO7451: 2007 heaped	Without side cutters	With side cutters			Arm 2.67 m	Arm 3.20 m	Arm 4.00 m
Hoe bucket (Level-pin type) (Level-pin type)	1.40	1 280	1 410	5	1 150	◎	◎	◎
	1.62	1 460	1 590	5	1 240	○	○	□
	1.86	1 640	-	5	1 200	◇	-	-
	1.40	1 280	1 410	5	1 130	◎	◎	◎
	1.62	1 460	1 590	5	1 240	○	○	□
Reinforced bucket	1.40	1 280	1 410	5	1 360	◎	◎	◎
	1.62	1 460	1 590	5	1 480	○	○	□
Rock bucket (Super V teeth) (Level-pin type) (Super V teeth) (Super V teeth)	1.38	-	1 360	5	1 330	△	△	-
	1.38	-	1 360	5	1 350	△	△	-
	1.50	-	1 470	5	1 400	△	△	-
	1.60	-	1 520	5	1 650	△	△	-
	1.80	-	1 450	5	1 610	△	-	-

ZX350LCH-7G

Bucket	Capacity (m ³)	Width (mm)		No. of teeth	Weight (kg)	Recommendation	
	ISO7451: 2007 heaped	Without side cutters	With side cutters			Arm 2.67 m H	Arm 3.20 m H
Reinforced bucket	1.40	1 280	1 410	5	1 360	◎	◎
	1.62	1 460	1 590	5	1 480	◎	○
Rock bucket (Super V teeth)	1.38	-	1 360	5	1 330	△	△

◎ Suitable for materials with density of 2 000 kg/m³ or less

○ Suitable for materials with density of 1 600 kg/m³ or less

◇ Suitable for materials with density of 1 400 kg/m³ or less

□ Suitable for materials with density of 1 100 kg/m³ or less

△ Rock digging

- Not applicable

* Heavy-duty

SPECIFICATIONS

WORKING RANGES

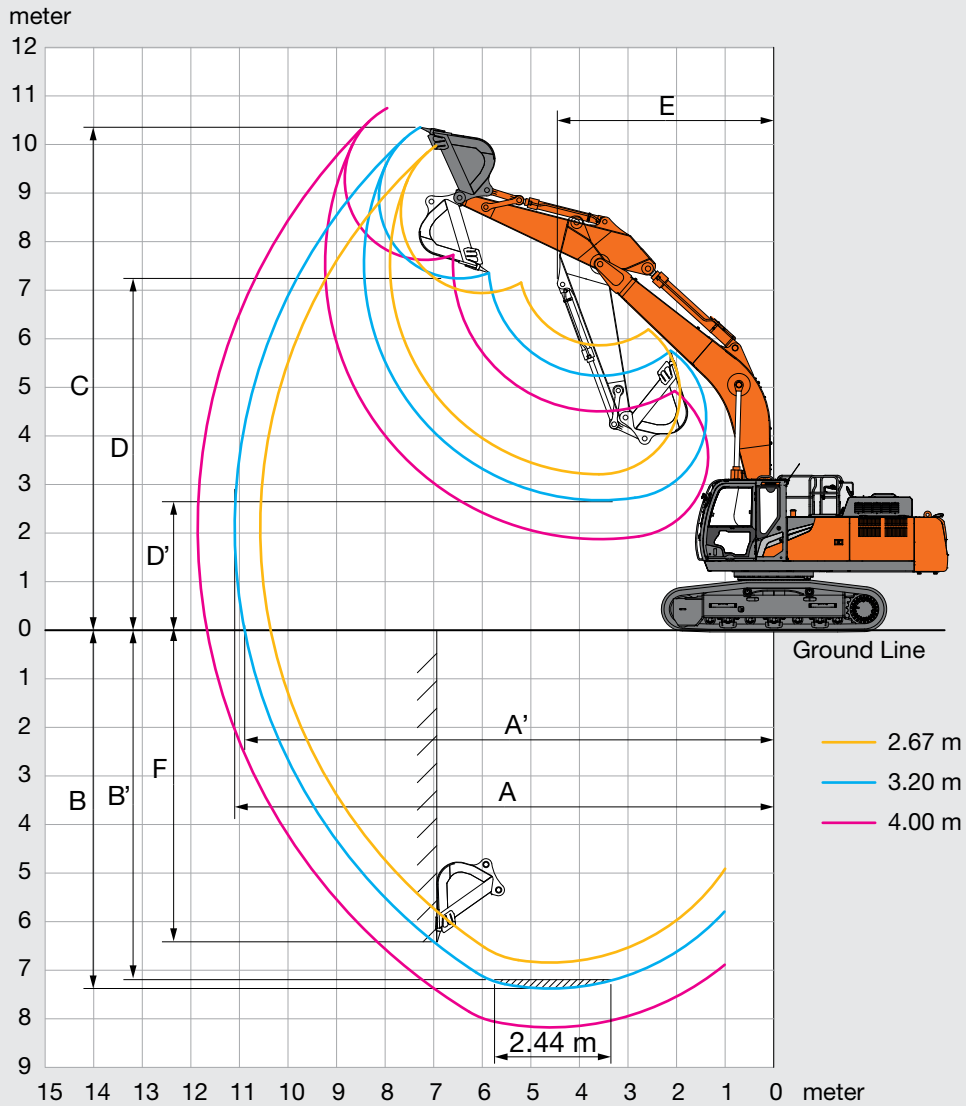

Unit: mm

Arm length	2.67 m	3.20 m	4.00 m
A Max. digging reach	10 570	11 100	11 860
A' Max. digging reach (on ground)	10 360	10 890	11 670
B Max. digging depth	6 840	7 380	8 180
B' Max. digging depth for 2.44 m level	6 640	7 210	8 040
C Max. cutting height	9 990	10 350	10 750
D Max. dumping height	6 940	7 240	7 630
D' Min. dumping height	3 210	2 680	1 880
E Min. swing radius	4 610	4 460	4 470
F Max. vertical wall digging depth	5 510	6 420	7 270

Excluding track shoe lug

DIMENSIONS

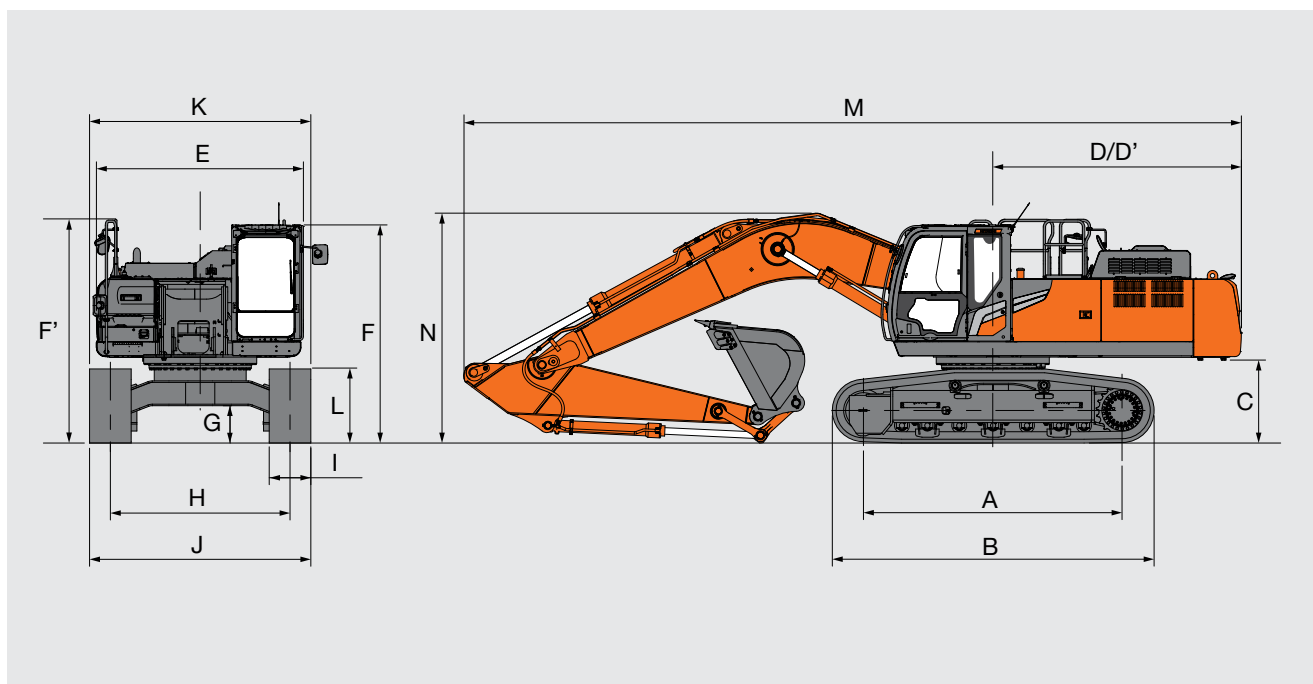

Unit: mm

Arm length	ZX350LC-7G	ZX350LCH-7G	
A Distance between tumblers	4 050	4 050	
B Undercarriage length	4 950	4 970	
*C Counterweight clearance	1 160	1 160	
D Rear-end swing radius	3 600	3 600	
D' Rear-end length	3 590	3 590	
E Overall width of upperstructure	2 990	2 990	
F Overall height of cab	3 150	3 150	
F' Overall height of upperstructure	3 230	3 230	
*G Min. ground clearance	500	500	
H Track gauge	2 590	2 590	
I Track shoe width	G 600	G 600	
J Undercarriage width	3 190	3 190	
K Overall width	3 190	3 190	
*L Track height with triple grouser shoes	1 060	1 070	
M Overall length			
	With Arm 2.67 m	11 350	11 350
	With Arm 3.20 m	11 220	11 220
	With Arm 4.00 m	11 330	-
*N Overall height of boom			
	With Arm 2.67 m	3 520	3 520
	With Arm 3.20 m	3 310	3 310
	With Arm 4.00 m	3 590	-

* Excluding track shoe lug G: Triple grouser shoe

MACHINE CAPACITIES

- Notes: 1. Ratings are based on ISO 10567 : 2007.
 2. Machine capacity does not exceed 75% of tipping load with the machine on firm, level ground or 87% full hydraulic capacity.
 3. The load point is the center-line of the bucket pivot mounting pin on the arm.
 4. *Indicates load limited by hydraulic capacity.
 5. 0 m = Ground.

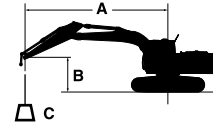

- A: Load radius
 B: Load point height
 C: Machine capacity

For machine capacities, subtract installed attachment and quick hitch weight from machine capacities.



To determine lifting capacities, apply "Rating over-side or 360 degrees" machine capacities from the table and deduct weight of installed attachment and quick hitch. Optional feature may affect machine performance.















ZX350LC-7G

Rating over-front Rating over-side or 360 degrees Unit : kg

Conditions	Load point height m	Load radius												At max. reach				
		1.5 m		3.0 m		4.5 m		6.0 m		7.5 m		9.0 m				meter		
Boom 6.40m H Arm 2.67m H Counterweight 6900kg Shoe 600mm	7.5																	
	6.0							*10 470	9 910	*9 740	6 960			9 540	6 240	8.00		
	4.5							*15 090	14 550	*11 830	9 460	*10 270	6 770	8 400	5 470	8.58		
	3.0							*18 610	13 330	*13 430	8 930	10 140	6 520	7 850	5 080	8.87		
	1.5									13 820	8 510	9 880	6 280	7 710	4 960	8.89		
	0 (Ground)							*20 290	12 420	13 540	8 270	9 710	6 130	7 940	5 080	8.65		
	-1.5			*13 890	*13 890	*19 600	12 450	13 470	8 210	9 670	6 100			8 660	5 510	8.13		
	-3.0			*22 600	*22 600	*17 520	12 640	*13 520	8 310					10 280	6 490	7.26		
	-4.5			*17 240	*17 240	*13 630	13 050							*10 130	8 910	5.88		
-6.0																		
Boom 6.40m H Arm 3.20m H Counterweight 6900kg Shoe 600mm	7.5																	
	6.0									*9 060	7 060			*6 310	5 620	8.58		
	4.5									*9 710	6 850	*7 470	5 110	*6 330	4 990	9.12		
	3.0							*17 360	13 720	*12 790	9 070	10 210	6 570	7 700	4 990	*6 550	4 660	9.39
	1.5							*19 920	12 820	13 930	8 600	9 920	6 310	7 570	4 870	*7 000	4 550	9.42
	0 (Ground)							*20 700	12 450	13 580	8 290	9 710	6 130	7 470	4 780	7 250	4 640	9.19
	-1.5			*13 320	*13 320	*20 170	12 380	13 440	8 170	9 620	6 040			7 810	4 980	8.70		
	-3.0	*15 640	*15 640	*21 080	*21 080	*18 530	12 500	13 480	8 210	9 680	6 100			9 020	5 730	7.90		
	-4.5			*20 290	*20 290	*15 370	12 820	*11 590	8 450					*9 860	7 380	6.66		
-6.0																		
Boom 6.40m H Arm 4.00m H Counterweight 6900kg Shoe 600mm	7.5													*5 030	*5 030	8.63		
	6.0									*8 030	7 190	*6 800	5 270	*4 880	4 850	9.41		
	4.5									*8 790	6 950	7 910	5 170	*4 880	4 370	9.91		
	3.0							*15 260	14 220	*11 620	9 250	*9 790	6 630	7 730	5 010	*5 020	4 100	10.16
	1.5							*18 500	13 090	*13 370	8 690	9 950	6 320	7 550	4 840	*5 320	4 000	10.18
	0 (Ground)			*8 060	*8 060	*20 190	12 450	13 580	8 280	9 670	6 080	7 400	4 700	*5 800	4 060	9.97		
	-1.5	*8 100	*8 100	*12 210	*12 210	*20 440	12 210	13 330	8 060	9 510	5 930	7 320	4 630	*6 590	4 300	9.53		
	-3.0	*12 710	*12 710	*17 650	*17 650	*19 500	12 220	13 280	8 020	9 480	5 900			7 600	4 810	8.80		
	-4.5	*18 210	*18 210	*23 960	23 960	*17 240	12 430	*13 050	8 140	9 640	6 050			*9 240	5 850	7.71		
-6.0			*17 350	*17 350	*12 860	*12 860	*9 030	8 550					*8 850	8 440	6.06			

ZX350LCH-7G

 Rating over-front  Rating over-side or 360 degrees Unit : kg

Conditions	Load point height m	Load radius												At max. reach			
		1.5 m		3.0 m		4.5 m		6.0 m		7.5 m		9.0 m				meter	
																	
Boom 6.40mH Arm 2.67mH Counterweight 7600kg Shoe 600mm	10.5																
	9.0																
	7.5																
	6.0							*10 240	*10 240	*9 500	7 330			*9 430	6 570	8.00	
	4.5					*14 790	*14 790	*11 560	9 990	*10 010	7 120			8 850	5 740	8.58	
	3.0					*18 210	14 080	*13 120	9 420	10 690	6 850			8 260	5 330	8.87	
	1.5							*14 350	8 960	10 410	6 600			8 100	5 190	8.89	
	0 (Ground)					*20 140	13 090	14 280	8 700	10 230	6 430			8 350	5 320	8.65	
	-1.5			*13 780	*13 780	*19 140	13 120	14 210	8 630	10 190	6 400			9 120	5 780	8.13	
	-3.0			*22 010	*22 010	*17 070	13 330	*13 160	8 750					*10 270	6 820	7.26	
-4.5			*16 700	*16 700	*13 230	*13 230							*9 800	9 390	5.88		
-6.0																	
Boom 6.40mH Arm 3.20mH Counterweight 7600kg Shoe 600mm	10.5																
	9.0																
	7.5																
	6.0									8 810	7 430			6 180	5 890	8.58	
	4.5							*10 800	10 150	9 440	7 200	*7 340	5 340	*6 210	5 220	9.12	
	3.0					*16 960	14 480	*12 460	9 550	10 290	6 900	8 090	5 220	*6 430	4 870	9.39	
	1.5					*19 450	13 500	*13 900	9 030	10 440	6 610	7 940	5 080	*6 870	4 740	9.42	
	0 (Ground)					*20 200	13 090	14 300	8 700	10 210	6 410	7 840	4 980	7 600	4 840	9.19	
	-1.5			*13 200	*13 200	*19 670	13 020	14 150	8 570	10 110	6 320			8 200	5 200	8.70	
	-3.0	*15 510	*15 510	*20 950	*20 950	*18 040	13 160	*13 730	8 620	10 180	6 380			9 490	5 990	7.90	
-4.5			*19 690	*19 690	*14 920	13 510	*11 210	8 880					*9 520	7 750	6.66		
-6.0																	

EQUIPMENT

● : Standard equipment ○ : Optional equipment – : Not applicable

ENGINE	ZX350LC-7G	ZX350LCH-7G
Air cleaner double filters	●	●
Alternator 50 A	●	●
Auto idle system	●	●
Auto shut-down control	●	●
Cartridge-type engine oil filter	●	●
Cartridge-type fuel main filter	●	●
Cartridge-type fuel pre-filter with water separator	●	●
Cold fuel resistance valve	●	●
ConSite OIL (sensor)*1	●	●
Dry-type air filter with evacuator valve (with air filter restriction indicator)	●	●
Dust-proof indoor net	●	●
ECO/PWR mode control	●	●
Electrical fuel feed pump	●	●
Engine oil drain coupler	●	●
Expansion tank	●	●
Fan guard	●	●
Fuel cooler	●	●
Isolation-mounted engine	●	●
Maintenance free pre-cleaner	●	●
Radiator, oil cooler and intercooler	●	●

HYDRAULIC SYSTEM	ZX350LC-7G	ZX350LCH-7G
Auto power lift	●	●
ConSite OIL (sensor)*1	●	●
Control valve with main relief valve	●	●
Full flow filter	●	●
High mesh full flow filter with restriction indicator	○	○
One extra port for control valve	●	●
Pilot filter	●	●
Power boost	●	●
Suction filter	●	●
Work mode selector	●	●

CAB	ZX350LC-7G	ZX350LCH-7G
Auto control air conditioner	●	●
Bluetooth® integrated radio	●	●
Console height adjustment	●	●
Cab : All-weather sound suppressed steel cab	●	●
Cab : CRES VII (center pillar reinforced structure) cab	●	●
Cab : ROPS (ISO12117-2:2008) compliant	●	●
Drink holder with hot and cool function	●	●
Electric double horn	●	●
Engine shut-off switch	●	●
Equipped with reinforced, tinted (green color) glass windows	●	●
Evacuation hammer	●	●
Floor mat	●	●
Footrest	●	●
Front guard : OPG Level II (ISO10262:1998) compliant	○	○
Front window washer (1 point)	●	●
Glove compartment	●	●
Hands-free calling device	●	●
Hot and cool box	●	●
Intermittent windshield wipers	●	●
Key cylinder light	●	●
LED room light	●	●
Magazine rack	●	●
Pilot shut-off lever	●	●
Power outlet 12 V	●	●
Power outlet 24 V	●	●
Rain guard (without OPG front guard)	○	○
Rear tray	●	●
Retractable seat belt	●	●
Rubber radio antenna	●	●
Seat : air suspension seat with heater	●	●
Seat adjustment part : backrest, armrest, height and angle, slide forward / back	●	●
Seat belt reminder	●	●
Short wrist control levers	●	●
Smartphone holder	●	●
Top guard : OPG Level II (ISO10262:1998) compliant	●	●
USB power supply	●	●
Windows on front, upper, lower and left side can be opened	●	●
2 speakers	●	●
4 fluid-filled elastic mounts	●	●
8 inch monitor	●	●

● : Standard equipment ○ : Optional equipment – : Not applicable

MONITOR SYSTEM	ZX350LC-7G	ZX350LCH-7G
Alarms: overheat, engine warning, engine oil pressure, alternator, minimum fuel level, hydraulic filter restriction, air filter restriction, work mode, overload, etc	●	●
Alarm buzzers: overheat, engine oil pressure, overload, trouble, etc	●	●
Display of meters: water temperature, hour, fuel rate, clock, etc	●	●
Other displays: work mode, auto-idle, glow, rear view monitor, operating conditions, etc	●	●
35 languages selection	●	●

LIGHTS	ZX350LC-7G	ZX350LCH-7G
Additional boom LED light with cover	○	○
Additional cab roof front LED lights	●	●
Additional cab roof rear LED lights	●	●
LED lights for camera (side and rear view camera)	●	●
2 working LED lights	●	●

UPPER STRUCTURE	ZX350LC-7G	ZX350LCH-7G
AERIAL ANGLE (270-degree view camera system)	●	●
Batteries	●	●
Counterweight 6 900 kg	●	–
Counterweight 7 600 kg	–	●
Fuel level float	●	●
Hydraulic oil level gauge	●	●
Lockable fuel refilling cap	●	●
Lockable machine covers	●	●
Lockable tool box	●	●
Platform handrail	●	●
Skid-resistant plates	●	●
Swing parking brake	●	●
Undercover 6.0 mm reinforced	●	●
Utility space	●	●
2 way disconnect switch	●	●

UNDERCARRIAGE	ZX350LC-7G	ZX350LCH-7G
Bolt-on sprocket	●	●
Full track guard	●	●
Greasing type track adjuster	●	●
Reinforced track links with pin seals	●	●
Shoe: 600 mm triple grouser	–	–
Shoe: 600 mm triple grouser reinforced	●	●
Shoe: 700 mm triple grouser	○ ²	○ ²
Shoe: 800 mm triple grouser	○ ²	○ ²
Towing hole for light weight object	●	●
Track side step (bolt on type)	●	●
Track undercover	●	●
Travel direction mark on track frame	●	●
Travel motor covers	●	●
Travel parking brake	●	●
Upper and lower rollers	●	●
4 tie down hooks	●	●

FRONT ATTACHMENTS	ZX350LC-7G	ZX350LCH-7G
Arm tip remote lubrication	●	●
Arm 2.67 m H	○	○
Arm 3.20 m H	●	●
Boom 6.40 m H	●	●
Bucket 1.40 m ³ (ISO7451 : 2007 heaped)	–	–
Bucket 1.38 m ³ rock (ISO7451 : 2007 heaped)	●	●
Casted bucket link A	●	●
Centralized lubrication system	●	●
Dirt seal on all bucket pins	●	●
Flanged pin	●	●
HN bushing	●	●
Reinforced link B	●	●
Reinforced resin thrust plate	●	●
WC (tungsten-carbide) thermal spraying	●	●

ATTACHMENTS	ZX350LC-7G	ZX350LCH-7G
Attachment basic piping	●	●
Breaker and crusher piping	●	●
High mesh full flow filter with restriction indicator	○	○
Line filter	○	●
Pilot accumulator	●	●
2 pump combined flow for attachment basic piping	○	○

MISCELLANEOUS	ZX350LC-7G	ZX350LCH-7G
ConSite	○	●
Global e-Service	●	●
Onboard information controller	●	●
Standard tool kit	●	●
Theft prevention system ^{*3}	○	○

Standard and optional equipment may vary by country, so please consult authorized dealer for details.

*1 Engine oil and hydraulic oil monitoring sensor.

*2 700 mm and 800 mm shoes are for soft soil, so please be careful when using H specification machines.

*3 Hitachi Construction Machinery cannot be held liable for theft, any system will just minimize the risk of theft.

Prior to operating this machine, including satellite communication system, in a country other than a country of its intended use, it may be necessary to make modifications to it so that it complies with the local regulatory standards (including safety standards) and legal requirements of that particular country. Please do not export or operate this machine outside the country of its intended use until such compliance has been confirmed. Please contact your Hitachi dealer in case of questions about compliance.

CablePrice Pty Ltd

www.cableprice.co.nz

Hitachi Construction Machinery Australia

www.hitachicm.com.au

These specifications are subject to change without notice.

Illustrations and photos show the standard models, and may or may not include optional equipment, accessories, and all standard equipment with some differences in color and features. Before use, read and understand the Operator's Manual for proper operation.

KS-EN524AU

00.00 (--/-- ---)

Printed in Australia