

ZAXIS-7G series

HITACHI

Reliable Solutions

ZAXIS690

Hitachi Construction Machinery Group

LANDCROS

Japanese Excellence—Reliable Solutions



HYDRAULIC EXCAVATOR

Model code : ZX690LCH-7G
Engine rated power : 345 kW (463HP)
Operating weight : 69 100 - 70 000 kg
Bucket capacity : 1.5 - 4.0 m³



GET MORE FROM YOUR MACHINE

You're at the heart of Hitachi Construction Machinery's design for its latest range of excavators. To continuously improve on previous generation machines, we've focused on enhancing your profit in business.

We have made cost reduction for our customers our top priority and, in doing so, have achieved reduced fuel consumption. The cab has been redesigned to improve the operator's working environment and controllability, with production also expected to improve. An engine that already has a proven track record of high reliability has been adopted, and we have placed further work in it to make it even more robust.



INSIDE



4-5 | MORE PRODUCTION
LOWER FUEL CONSUMPTION



6-7 | BETTER
OPERABILITY



8-9 | HIGH DURABILITY
AND RELIABILITY



10-11 | GREATER DURABILITY IN
QUARRY SITES R-series



12-13 | SMOOTH
MAINTENANCE



14-15 | MACHINE
MANAGEMENT

MORE PRODUCTION LOWER FUEL CONSUMPTION

The HIOS-V new Hydraulic system has achieved both increased productivity and reduced fuel consumption in each mode. The ZAXIS performance contributes to increase the returns to the customer.

HIOS-V Hydraulic system

The hydraulic system developed was based on the concept of a hydraulic system that fits in-line with a sense of human operation.

- ✓ Efficient hydraulic control achieves smoother and more speedy movement of front attachments.
- ✓ Fine-tuned hydraulic pump control according to work load reduces fuel consumption and supports cost reductions.

Reduced oil pressure loss

A new valve has been adopted to reduce hydraulic loss and further improve hydraulic efficiency.

- ✓ Contributing to low fuel consumption operation

High power engine

Rated output (ISO 14396:2002)	345kW
----------------------------------	--------------

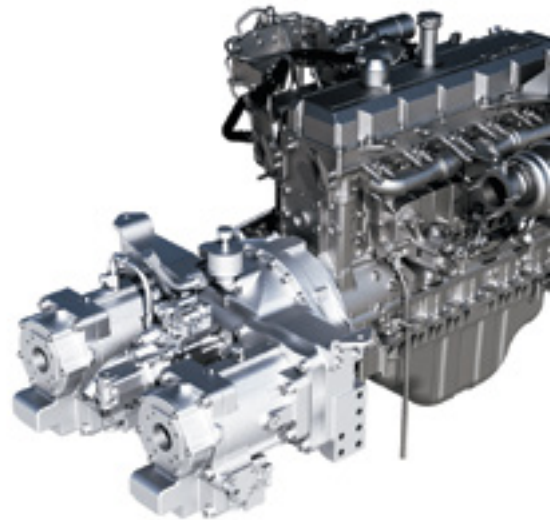

High efficiency operation support system

ECO gauge

The current fuel consumption is indicated by segment display, prompting the operator to better fuel economy. The lower the fuel consumption, the higher the segment.

Easy to be removed and cleaned

ECO guidance

Prompts the operator to better fuel economy.

Messages are also shown while the ECO gauge is displayed.

- ✓ Prompts operator for better economy

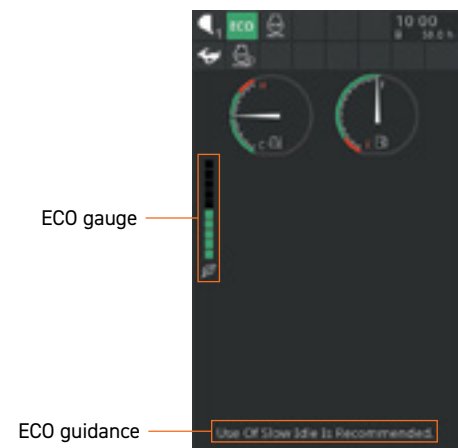



BETTER OPERABILITY

In the cab of the ZAXIS-7G, enhanced comfort and safety features are at your fingertips, offering the power to perform greater productivity with ease as well as reduced fatigue.



Operation is easy with ergonomically designed controls and switches.



Low-reflective color 8" monitor. Easier to view and navigate. Bluetooth® and USB power supply available.



New designed pilot shut-off lever
The newly designed pilot shut-off lever allows easier locking and unlocking with wrist operation.

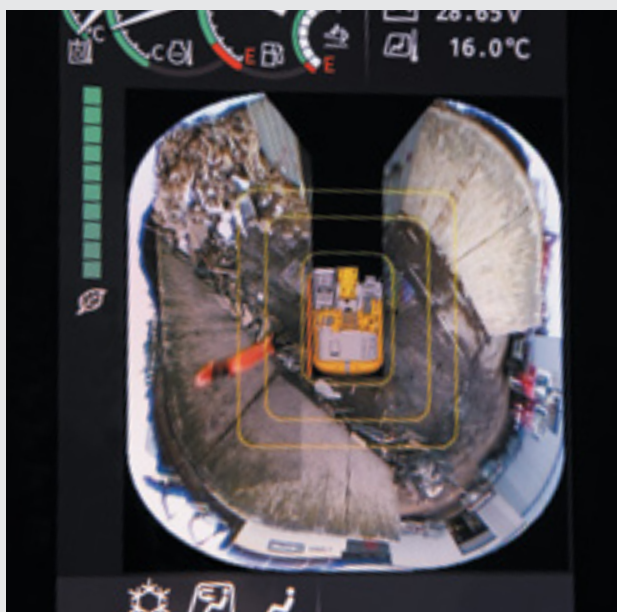

AERIAL ANGLE (Optional)
270-degree bird's eye-view camera system is available as an option.

HIGH DURABILITY AND RELIABILITY

Completing a project on time and on budget depends on the ability of your construction equipment to perform all day, every day. That's why Hitachi construction machinery owners have profited from generations of reliable and durable machinery. Hitachi Construction Machinery is always conscious of improving long-term reliability in its machine development. High long-term reliability is good in not only performance all day, every day but also for resale value.

H Boom

Complete joint penetration has been applied to areas where the load is focused, and durability and reliability have been further improved.



H Arm

A forged boss is used in the arm rod. Complete joint penetration has been applied to areas where the load is focused, and durability and reliability have been further improved.

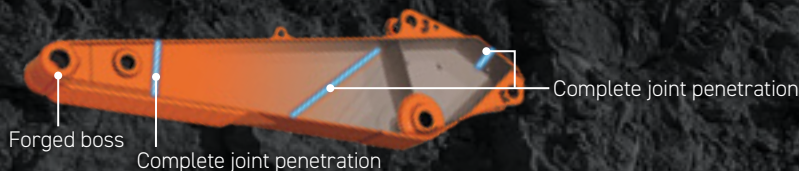

Rock bucket

A rock bucket has been adopted in consideration for sites requiring heavier excavator work. Equipped with horizontal wear plates and two-piece side shrouds for increased durability.

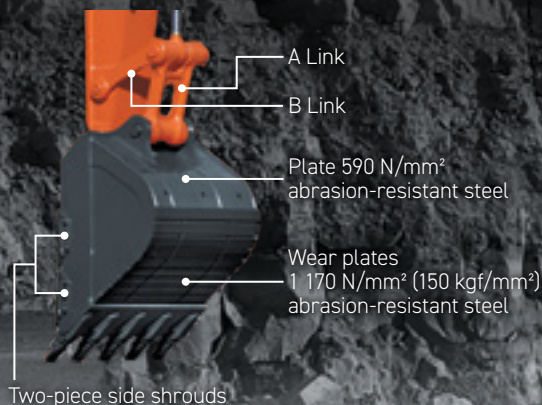

Undercarriage

Full track guard

Protects the lower roller and link from boulders and extending the unit's operating life.



Equipped with an Expansion tank

✔ Improving the reliability of the engine cooling performance



An engine with improved reliability

The engine is a highly reliable model that has already been adopted previously. In adopting it for the ZX-7G, we have put in our efforts to further increase durability and to BOOST your uptime. EGR (Exhaust Gas Recirculation) is removed from the engine, increasing its durability for using low-quality fuel.



H-front attachment
(Same as the standard model)

H/R Cab



A reinforced cab for H&R specification machines with a reinforced windshield and a FOPS* guard that protects the cab from falling objects. The front has a laminated straight glass front window that shuts out dust. The cab front guard (optional), also complies with the ISO standard OPG**.

*FOPS: Falling-Object Protective Structure
**OPG: Operator Protective Guards

Reinforced undercover

Laminated straight glass front window



SMOOTH MAINTENANCE

Regular maintenance is essential for the machine to achieve high performance.

Hitachi's excavator is designed for ease of regular maintenance. Simple and easy maintenance keeps the machine in good condition and keeps its high performance.



Easy-access air conditioner condenser

- ✓ The cover can be opened without the need for any tools
- ✓ Easy to clean Radiator/Oil Cooler/Inter cooler core with simple air blowing



Dust-proof net on right side cover

- ✓ Provided on the cover, in front of radiator core
- ✓ Easy cleaning with compressed air



Simplified engine oil drainage

- ✓ Drain work can be done more easily by attaching a dedicated nozzle hose.



Side walk

- ✓ Easy to move from cab to pump room or platform



Easy access to filters

Filter locations are concentrated for easy access

1 Fuel main filter 2 Fuel pre-filter with water separator 3 Engine oil filter

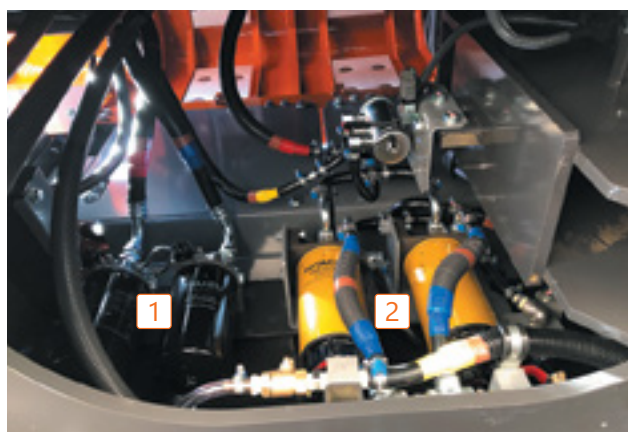

MACHINE MANAGEMENT

Hitachi Construction Machinery offers a wide range of after-sales services to help you feel in total control of your fleet and workload. These initiatives give you access to vital data and tools to manage your machine.



ConSite
Consolidated Solution for Construction Sites



A wide range of data on Global e-Service enhances efficiency.

Data report

Regular reports inform you of the machine's operation status. Emergency reports inform you of alarm information.

The stable operation of the machine is further supported with two types of reports visualizing the machine's daily operation status.

Monthly report

Regular reports on the operating status of each machine.

Alarm report

If an emergency alarm is generated from a sensor mounted on the machine, its alarm content is reported by e-mail in a timely manner. You can receive it on your computer, mobile phone, or smartphone (communication format is via e-mail).

movie for
further info.





ConSite Pocket

ConSite Pocket sends you real-time alerts for issues arising with your machine. You'll receive recommendations on what to do and step-by-step help guides. The app also enables you to see the location of your fleet.

- Use your smartphone to check monthly reports, alarm reports, as well as machine operating positions.
- If an alarm report is generated, the system will notify you immediately using a push notification.

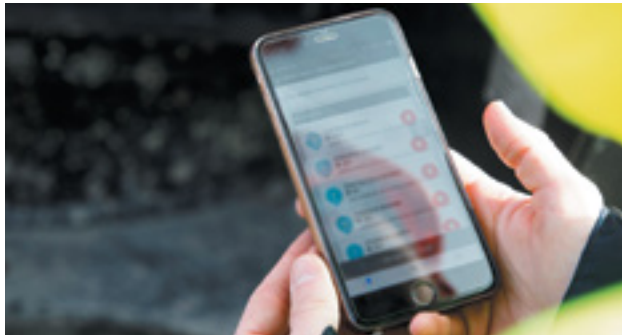

Monthly report



Machine finder



Location information

movie for further info.

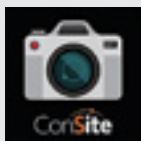

ConSite Shot

This is a smartphone application that allows you to easily perform daily inspections of your machines and rental warehousing / delivery management.

- You can easily create high-quality inspection reports and share information within your company or with agents etc.
- Customers who have rental machines can also use it during rental warehousing / delivery inspections.



Load condition



Acceptance or delivery inspection of rental machines



Inspection report with condition photo

movie for further info.



ConSite OIL

This system detects if the oil quality has deteriorated, due to contamination or low viscosity. If this happens, you and your authorized dealer will receive an alert.

movie for further info.



SPECIFICATIONS

ENGINE	
Model	Isuzu AE-6WG1XWSA
Type	4-cycle water-cooled, common rail direct injection
Aspiration	Variable geometry turbocharged, intercooled
No. of cylinders	6
Rated power	
ISO 14396 : 2002 gross	345 kW (463 HP) at 1 800 min ⁻¹ (rpm)
ISO 9249 : 2007 net	344 kW (461 HP) at 1 800 min ⁻¹ (rpm)
Maximum torque	1 980 Nm (202 kgfm) at 1 500 min ⁻¹ (rpm)
Piston displacement	15.681 L
Bore and stroke	147 mm x 154 mm
Batteries	2 x 12 V

HYDRAULIC SYSTEM			
Hydraulic Pumps			
Main pumps	2 variable displacement axial piston pumps		
Maximum oil flow	2 x 443 L/min		
Pilot pump	1 gear pump		
Maximum oil flow	50 L/min		
Hydraulic Motors			
Travel	2 axial piston motors with parking brake		
Swing	2 axial piston motors		
Relief Valve Settings			
Implement circuit	31.9 MPa (325 kgf/cm ²)		
Swing circuit	29.4 MPa (300 kgf/cm ²)		
Travel circuit	34.3 MPa (350 kgf/cm ²)		
Pilot circuit	3.9 MPa (40 kgf/cm ²)		
Power boost	34.3 MPa (350 kgf/cm ²)		
Hydraulic Cylinders			
	Quantity	Bore	Rod diameter
Boom	2	190 mm	130 mm
Arm	1	200 mm	140 mm
Bucket	1	180 mm	130 mm
Bucket (BE)	1	190 mm	130 mm

UPPERSTRUCTURE	
Revolving Frame	
D-section frame for resistance to deformation.	
Swing Device	
Axial piston motor with planetary reduction gear is bathed in oil. Swing circle is single-row. Swing parking brake is spring-set/hydraulicreleased disc type.	
Swing speed	8.5 min ⁻¹ (rpm)
Swing torque	194 kNm (19 800 kgfm)

UNDERCARRIAGE	
Tracks	
Heat-treated connecting pins with dirt seals. Hydraulic (grease) track adjusters with shock-absorbing recoil springs.	
Numbers of Rollers and Shoes on Each Side	
Upper rollers	3
Lower rollers	8
Track shoes	47
Track guards	Full track guard
Travel Device	
Each track driven by axial piston motor through reduction gear for counterrotation of the tracks. Parking brake is spring-set/hydraulic-released disc type. Automatic transmission system: High-Low.	
Travel speeds	High : 0 to 4.9 km/h
	Low : 0 to 3.4 km/h
Maximum traction force	483 kN (49 300 kgf)
Gradeability	70 % (35 degree) continuous

SERVICE REFILL CAPACITIES	
Fuel tank	920.0 L
Engine coolant	86.0 L
Engine oil	52.0 L
Pump drive	6.2 L
Swing device (each)	10.5 L
Travel device (each side)	16.0 L
Hydraulic system	750.0 L
Hydraulic oil tank	380.0 L

WEIGHTS AND GROUND PRESSURE

Operating Weight and Ground Pressure

ZX690LCH-7G

Shoe grouser type	Shoe width	Arm type	Boom type	Bucket Capacity (ISO7451 : 2007 heaped)	Operating weight	Ground pressure	
	mm				kg	kPa	kgf/cm ²
Double	650	2.9 m BE	6.8 m BE	3.3 m ³ Rock Bucket	69 100	104	1.06
		3.6 m H	7.8 m H	2.9 m ³ Rock Bucket	69 200	104	1.06

BUCKET AND ARM DIGGING FORCE

ZX690LCH-7G

Boom length	6.8 m BE		7.8 m H	
	Arm length			
	2.9 m BE		3.6 m H	
	kN	kgf	kN	kgf
Bucket digging force ISO 6015 : 2006	369	37 700	324	33 100
Arm crowd force ISO 6015 : 2006	306	31 200	255	26 000

At power boost

BACKHOE ATTACHMENTS

ZX690LCH-7G

Bucket	Capacity (m ³)	Width (mm)		No. of teeth	Weight (kg)	Boom 6.8 m BE	Boom 7.8 m H
	ISO 7451 : 2007 heaped	Without side cutters	With side cutters			Arm 2.9 m BE	Arm 3.6 m H
Rock bucket	2.9	1 610	1 675	5	2 850	×	●
	3.3	1 710	1 775	5	3 110	●	×
	4.0	1 905	1 970	5	3 700	○	×
Ripper bucket	1.5	–	1 310	3	3 150	×	●
	1.8	–	1 570	3	3 750	●	×
One-point ripper				1	1 800	●	●
Applicable shoe type						650 mm double grouser	

● Heavy-duty service

○ Suitable for material with density of 1 600 kg/m³ or less

× Can't be installed

SPECIFICATIONS

ZX690LCH-7G

WORKING RANGES

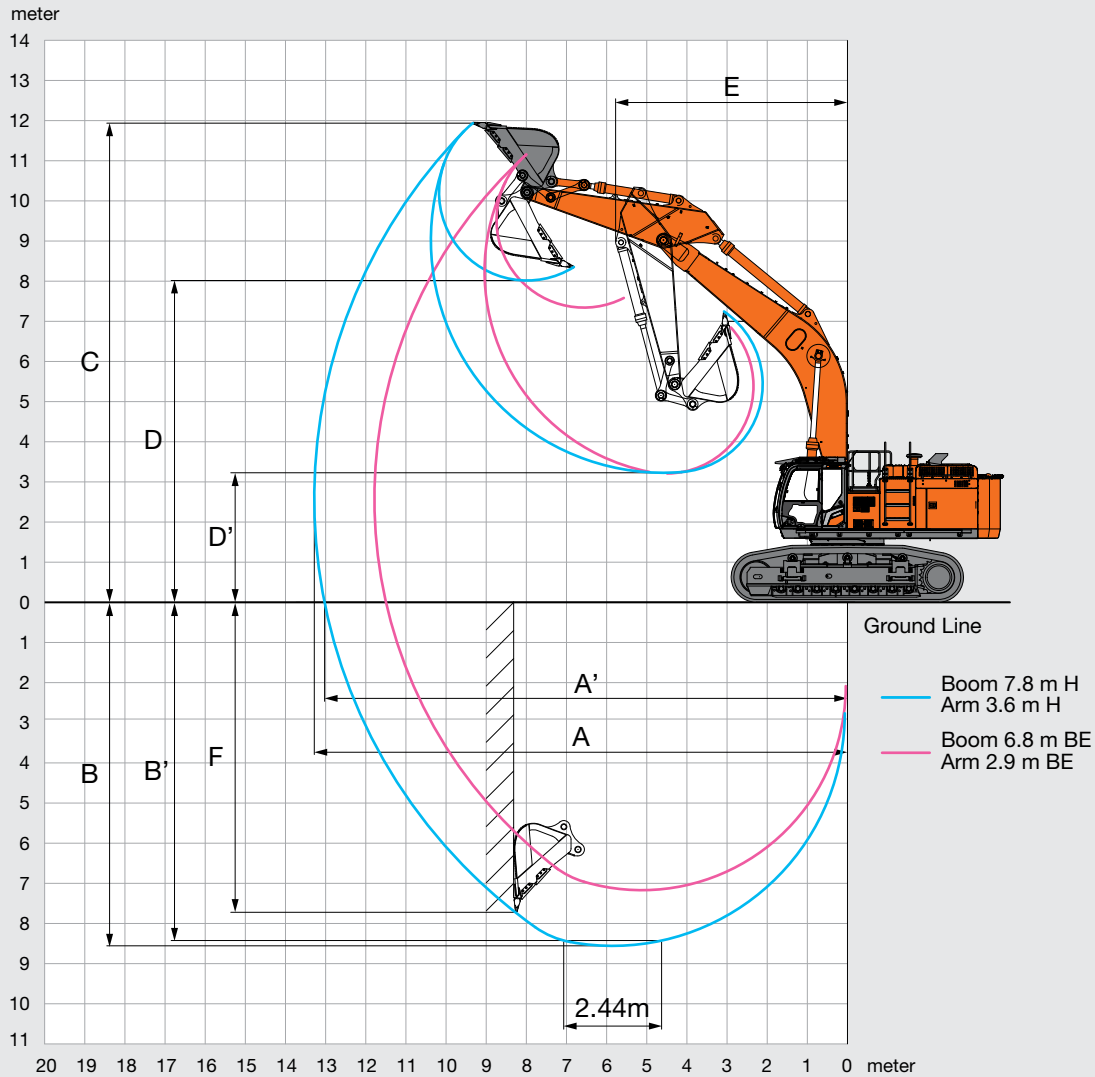

Unit: mm

	ZX690LCH-7G	
Boom	6.8 m BE	7.8 m H
Arm length	2.9 m BE	3.6 m H
A Max. digging reach	11 800	13 280
A' Max. digging reach (on ground)	11 500	13 030
B Max. digging depth	7 120	8 560
B' Max. digging depth for 2.44 m level	6 970	8 420
C Max. cutting height	11 190	11 940
D Max. dumping height	7 330	8 020
D' Min. dumping height	3 200	3 230
E Min. swing radius	5 240	5 780
F Max. vertical wall digging depth	5 280	7 720

Excluding track shoe lug

DIMENSIONS

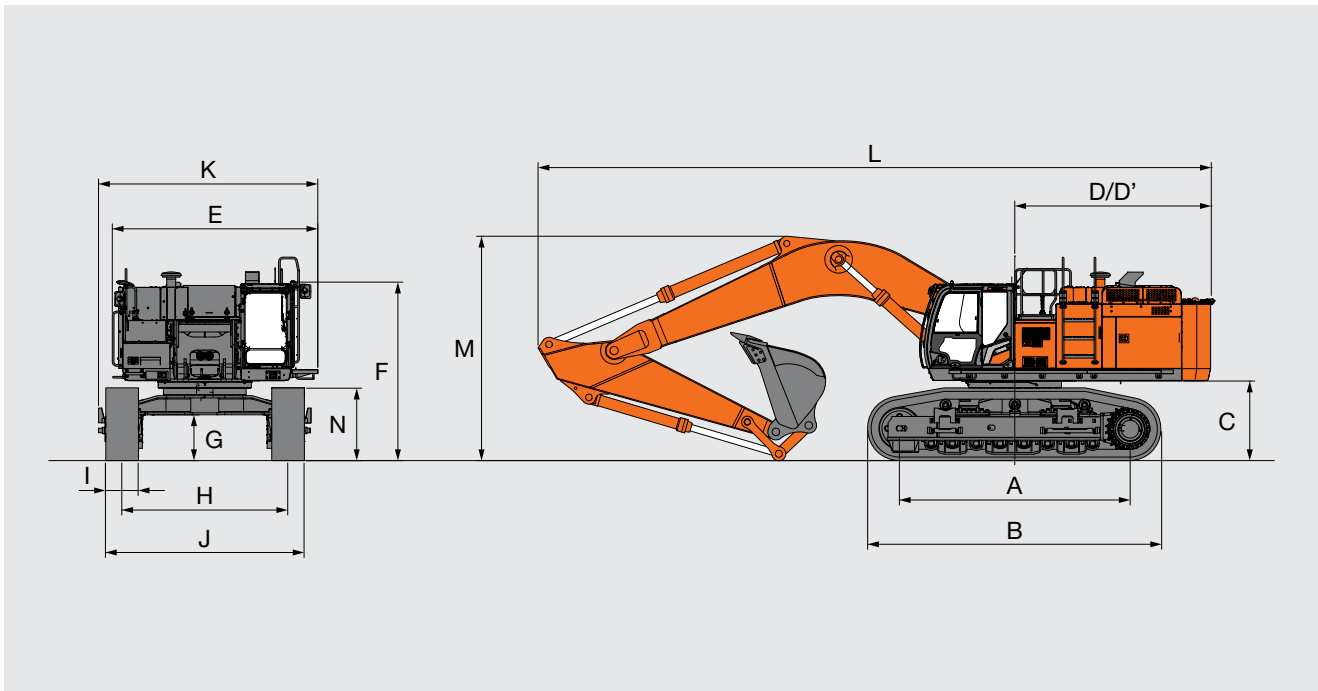

Unit: mm

	ZX690LCH-7G
A Distance between tumblers	4 590
B Undercarriage length	5 840
*1C Counterweight clearance	1 530
D Rear-end swing radius	4 020
D' Rear-end length	3 910
E Overall width of upperstructure	4 090
F Overall height of cab	3 660
*1G Min. ground clearance	860
H Track gauge	3 300
I Track shoe width	650
J Undercarriage width with 650 mm shoe	3 950
K Overall width	4 360
*2L Overall length	13 400
*2M Overall height of boom	4 460
*2N Track height	1 440

*1 Excluding track shoe lug

*2 with Boom 7.8 m and Arm 3.6 m

MACHINE CAPACITIES

- Notes: 1. Ratings are based on ISO 10567 : 2007.
 2. Machine capacity does not exceed 75% of tipping load with the machine on firm, level ground or 87% full hydraulic capacity.
 3. The load point is the center-line of the bucket pivot mounting pin on the arm.
 4. *Indicates load limited by hydraulic capacity.
 5. 0 m = Ground.

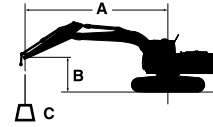

A: Load radius
 B: Load point height
 C: Machine capacity

For machine capacities, subtract installed attachment and quick hitch weight from machine capacities.

To determine lifting capacities, apply "Rating over-side or 360 degrees" machine capacities from the table and deduct weight of installed attachment and quick hitch. Optional feature may affect machine performance.

ZX690LCH-7G

Rating over-front Rating over-side or 360 degrees Unit : kg

Conditions	Load point height m	Load radius												At max. reach		
		3.0 m		4.5 m		6.0 m		7.5 m		9.0 m		10.5 m		meter		
Boom 7.8 m H Arm 3.6 m H Counterweight 10 400 kg Shoe 650 mm	7.5									*13 510	*13 510			*9 300	*9 300	9.9
	6.0							*15 670	*15 670	*14 180	13 190	*9 770	*9 770	*9 330	*9 330	10.5
	4.5					*21 570	*21 570	*17 470	16 820	*15 160	12 740	*13 600	9 970	*9 590	9 320	10.9
	3.0					*25 710	22 070	*19 270	16 010	*16 220	12 270	13 540	9 710	*10 090	8 910	11.1
	1.5					*26 760	21 060	*20 690	15 360	16 720	11 860	13 290	9 470	*10 890	8 790	11.0
	0 (Ground)			*15 130	*15 130	*27 490	20 530	*21 460	14 920	16 400	11 560	13 120	9 310	*12 110	8 970	10.8
	-1.5			*23 220	*23 220	*27 090	20 360	21 260	14 720	16 240	11 410			13 420	9 510	10.3
	-3.0	*22 490	*22 490	*32 660	*32 660	*25 640	20 430	*20 510	14 720	16 270	11 440			14 980	10 590	9.6
	-4.5	*32 920	*32 920	*28 660	*28 660	*22 850	20 760	*18 200	14 960					*15 290	12 680	8.5
-6.0			*22 270	*22 270	*17 700	*17 700							*14 720	*14 720	6.9	
Boom 6.8 m BE Arm 2.9 m BE Counterweight 10 400 kg Shoe 650 mm	7.5							*16 810	*16 810					*12 500	*12 500	8.2
	6.0					*19 710	*19 710	*17 550	*17 550					*12 210	*12 210	9.0
	4.5					*22 640	*22 640	*18 960	17 000	*17 010	12 810			*12 320	11 910	9.4
	3.0					*25 600	22 600	*20 520	16 320	17 360	12 480			*12 810	11 310	9.6
	1.5					*27 590	21 600	*21 730	15 760	17 030	12 180			*13 740	11 200	9.6
	0 (Ground)					*28 180	21 170	21 990	15 410	16 850	12 000			*15 290	11 580	9.3
	-1.5			*35 530	33 380	*27 310	21 060	*21 550	15 310					*17 760	12 620	8.7
	-3.0	*37 800	*37 800	*31 570	*31 570	*24 670	21 270	*18 920	15 540					*17 710	14 840	7.8
	-4.5			*24 650	*24 650	*18 660	*18 660							*16 670	*16 670	6.4
-6.0																

TRANSPORTATION

UPPERSTRUCTURE

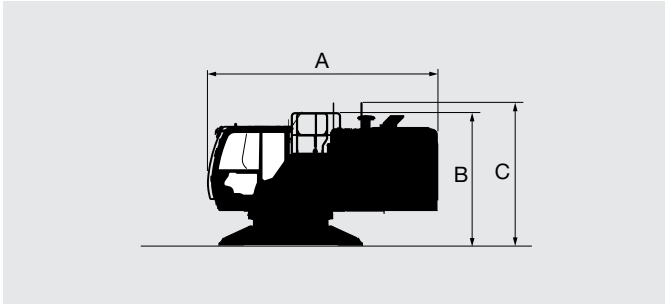

BOOM

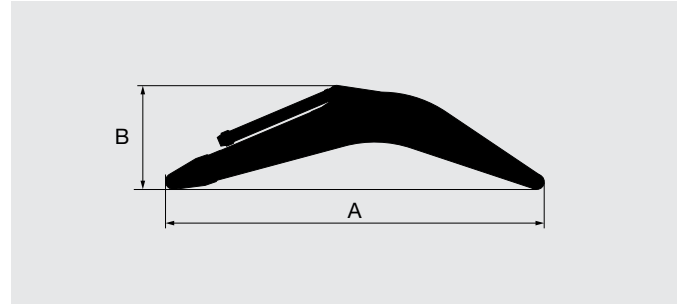

BASIC MACHINE (WITHOUT COUNTERWEIGHT)

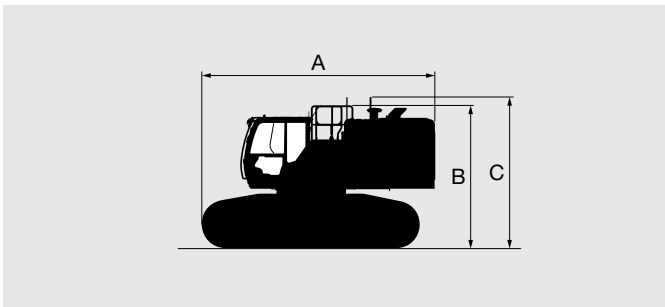

ARM

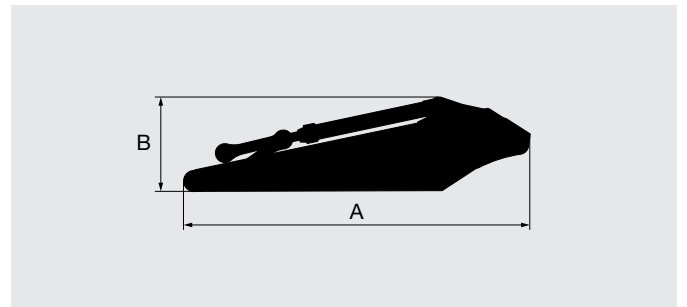

SIDE FRAME

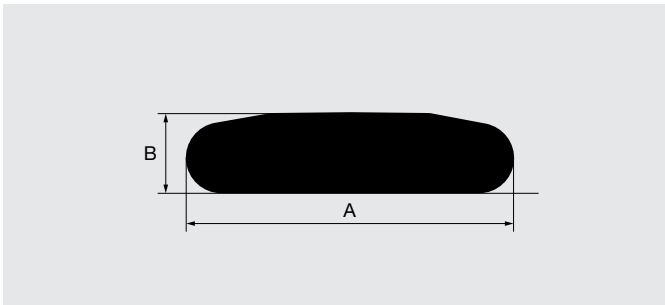

BUCKET

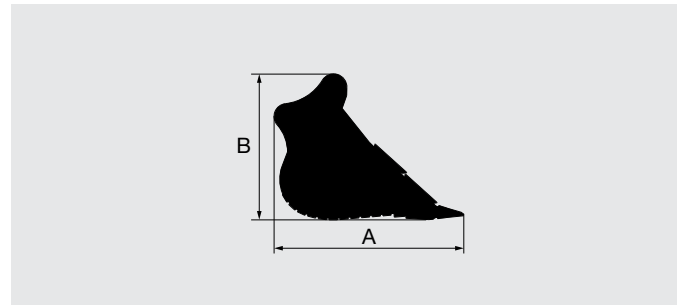

COUNTERWEIGHT

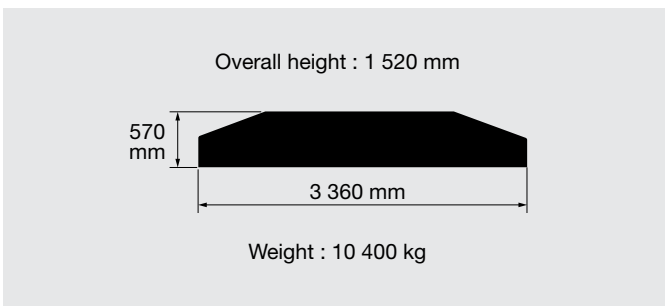

BOOM CYLINDERS 550 kg X 2 Overall height : 410 mm

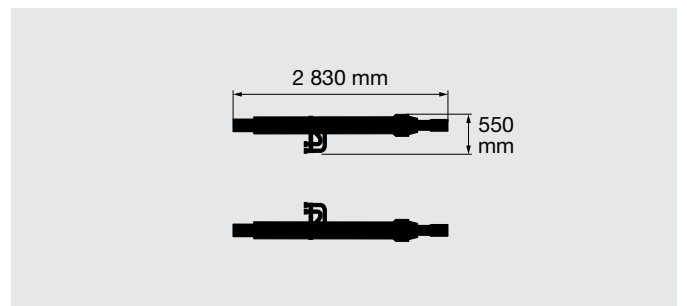

LEFT SIDEWALK Overall height : 150 mm

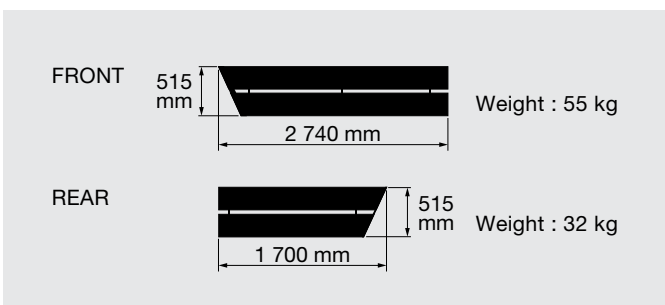

HOSE OF BOOM CYLINDERS 7 kg X 2 / 10 kg X 2

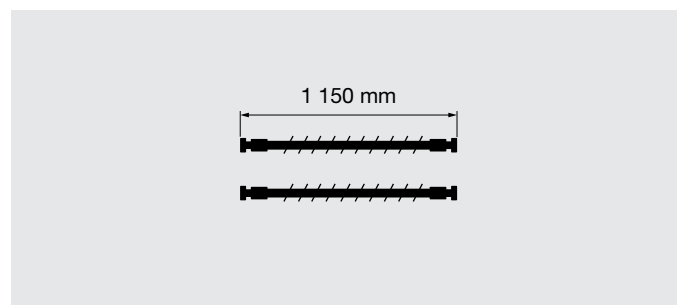

UPPERSTRUCTURE

Fixed gauge	A (mm)	B (mm)	C (mm)	Overall width (mm)	Weight (kg)
ZX690LCH-7G	5 220	2 910	3 140	3 470	21 100

BASIC MACHINE (WITHOUT COUNTERWEIGHT)

Fixed gauge	Shoe width (mm)	A (mm)	B (mm)	C (mm)	Overall width (mm)	Weight (kg)
ZX690LCH-7G	650	6 240	3 820	4 050	3 480	44 400

Notes : Undercarriage retracted.

SIDE FRAME

Fixed gauge	Shoe width (mm)	A (mm)	B (mm)	Overall width (mm)	Weight (kg)
ZX690LCH-7G	650	5 840	1 450	1 250	10 600

BOOM

Boom	A (mm)	B (mm)	Overall width (mm)	Weight (kg)
6.8 m BE	7 140	2 510	1 390	6 110
7.8 m H	8 130	2 330	1 390	6 560
7.8 m R	8 130	2 330	1 390	6 760

ARM

Arm	A (mm)	B (mm)	Overall width (mm)	Weight (kg)
2.9 m BE	4 370	1 690	800	3 820
3.6 m H	5 110	1 440	800	3 750
3.6 m R	5 110	1 440	800	3 900

BUCKET

Bucket	Bucket Capacity ISO heaped (m ³)	A (mm)	B (mm)	Overall width (mm)	Weight (kg)
Hoe bucket	2.5	2 220	1 810	1 620	2 150
	2.9	2 220	1 810	1 820	2 310
	3.5	2 250	1 890	1 990	2 980
Rock bucket	2.9	2 290	1 770	1 680	2 850
	3.3	2 250	1 890	1 790	3 110
	4.0	2 360	1 930	1 970	3 700
R bucket	2.9	2 290	1 770	1 680	3 300
	3.3	2 250	1 890	1 790	3 610

EQUIPMENT

● : Standard equipment ○ : Optional equipment – : Not applicable

ENGINE	
Alternator 60 A	●
Auto idle system	●
Auto shut-down control	●
Cartridge-type engine oil filter	●
Cartridge-type fuel main filter	●
Cartridge-type fuel pre-filter with water separator	●
ConSite OIL (sensor)*1	●
Dry-type air filter with evacuator valve (with air filter restriction indicator)	●
Dust-proof net	●
ECO/PWR/HP mode control	●
Electrical fuel feed pump	●
Engine oil drain coupler	●
Expansion tank	●
Fan guard	●
Isolation-mounted engine	●
Pre-cleaner	●
Radiator, oil cooler and intercooler	●
Reversible fan	●

HYDRAULIC SYSTEM	
Auto power lift	●
Boom mode selector system	●
ConSite OIL (sensor)*1	●
Control valve with main relief valve	●
Drain filter	●
Engine speed sensing system	●
Extra port for control valve	●
High mesh full flow filter	●
Pilot filter	●
Power boost	●
Shockless valve in pilot circuit	●
Suction filter	●
Two extra port for control valve	●
Work mode selector	●

CAB	
Auto control air conditioner	●
Bluetooth® radio	●
Cab : All-weather sound suppressed HD steel cab	●
Console height adjustment	●
Drink holder with hot and cool function	●
Electric double horn	●
Engine shut-off switch	●
Evacuation hammer	●
Fire extinguisher bracket	●
Floor mat	●
Footrest	●
Front guard : OPG front guard Level II (ISO 10262 : 1998) compliant	○
Front window washer (1 points)	●
Glove compartment	●
Hands-free calling device	●
Hot and cool box	●
Intermittent windshield wipers	●
Key cylinder light	●
Laminated straight glass front window	●
LED room light	●
Magazine rack	●
Pilot shut-off lever	●
Power outlet 12 V	○
Power outlet 24 V	●
Rain guard (without OPG front guard)	○
Rear tray	●
Retractable seat belt	●
Rubber radio antenna	●
Seat : air suspension seat with heater	●
Seat adjustment part : backrest, armrest, height and angle, slide forward / back	●
Seat belt reminder	●
Short wrist control levers	●
Smartphone holder	●
Sunscreen roller type (multi-use front or side and rear window)	●
Top guard : OPG top guard Level II (ISO 10262 : 1998) compliant	●
Transparent roof with slide curtain	●
USB power supply	●
Windows on leftside can be opened	●
2 speakers	●
6 fluid-filled elastic mounts	●
8 inch monitor	●

● : Standard equipment ○ : Optional equipment – : Not applicable

MONITOR SYSTEM	
Alarms : overhear, engine warning, engine oil pressure, alternator, minimum fuel level, hydraulic filter restriction, air filter restriction, work mode, overload, etc	●
Alarm buzzers : overhear, engine oil pressure, overload, trouble, etc	●
Display of meters : water temperature, hour, fuel rate, clock, etc	●
Other displays : work mode, auto-idle, glow, rear view monitor, operating conditions, etc	●
35 languages selection	●

LIGHTS	
Additional boom LED light with cover	○
Additional cab roof front 2 LED lights	●
Additional cab roof front 4 LED lights	○
Additional cab roof rear 1 LED light	●
LED lights for camera (side and rear view camera)	●
Rotating lamp	○
2 working LED lights	●

UPPERSTRUCTURE	
AERIAL ANGLE (270-degree view camera system)	●
Auto-grease lubricator (without bucket and link pins)	○
Batteries	●
Body top handrail	●
Counterweight 10 400 kg	●
Electric fuel refilling pump with auto stop and filter	○
Electrical grease pump with hose-reel	●
Fuel level float	●
Hydraulic oil level gauge	●
Ladder	●
Lockable fuel refilling cap	●
Lockable machine covers	●
Lockable tool box	●
Platform handrail	●
Sidewalk (cab side)	●
Skid-resistant plates and handrails	●
Swing parking brake	●
Undercover	●
Utility space	●
2 way disconnect switch	●

UNDERCARRIAGE	
Bolt-on sprocket	●
Full track guard	●
Hydraulic track adjuster	●
Idler track guard	●
Lower rollers (single flange)	●
Lower rollers (double flange)	○
Reinforced track links with pin seals	●
Shoe: 650 mm double grouser	●
Track undercover	●
Travel direction mark on track frame	●
Travel motor covers	●
Travel parking brake	●
Upper rollers	●

FRONT ATTACHMENTS	
Arm 2.9 m BE	○
Arm 3.6 m H	●
Boom 6.8 m BE	○
Boom 7.8 m H	●
Centralized lubrication system	●
Damage prevention plate and square bars	●
Dirt seal on all bucket pins	●
Flanged pin	●
Link B	●
Monolithically cast bucket link A	●

MISCELLANEOUS	
ConSite	●
Global e-Service	●
Onboard information controller	●
Standard tool kit	●
Theft prevention system*2	○

Standard and optional equipment may vary by country, so please consult authorized dealer for details.

*1 Engine oil and hydraulic oil monitoring sensor.

*2 Hitachi Construction Machinery cannot be held liable for theft, any system will just minimize the risk of theft.

Prior to operating this machine, including satellite communication system, in a country other than a country of its intended use, it may be necessary to make modifications to it so that it complies with the local regulatory standards (including safety standards) and legal requirements of that particular country. Please do not export or operate this machine outside the country of its intended use until such compliance has been confirmed. Please contact your Hitachi dealer in case of questions about compliance.

These specifications are subject to change without notice. Illustrations and photos show the standard models, and may or may not include optional equipment, accessories, and all standard equipment with some differences in color and features. Before use, read and understand the Operator's Manual for proper operation.

CablePrice Pty Ltd
www.cableprice.co.nz

Hitachi Construction Machinery Australia
www.hitachicm.com.au

KS-EN551AU

00.00 (--- ---)

Printed in Australia