

ZAXIS-7G series

HITACHI

Reliable Solutions

ZAXIS210

Hitachi Construction Machinery Group
LANDCROS
Japanese Excellence—Reliable Solutions



HYDRAULIC EXCAVATOR

Model code : ZX210LC-7G
Engine rated power : 120 kW (161HP)
Operating weight : 19 800 - 21 100 kg
Bucket capacity : 0.80 - 1.10 m³



GET MORE FROM YOUR MACHINE

You're at the heart of Hitachi Construction Machinery's design for its latest range of excavators. To continuously improve on previous generation machines, we've focused on enhancing your profit in business.

We have made cost reduction for our customers our top priority and, in doing so, have achieved reduced fuel consumption. The cab has been redesigned to improve the operator's working environment and controllability, with production also expected to improve. An engine that already has a proven track record of high reliability has been adopted, and we have placed further work in it to make it even more robust.



INSIDE



4-5 | MORE FUEL EFFICIENCY



6-7 | BETTER OPERABILITY



8-9 | HIGH DURABILITY AND RELIABILITY



10-11 | SMOOTH MAINTENANCE



12-13 | MACHINE MANAGEMENT

MORE FUEL EFFICIENCY

Improved HIOSIII hydraulic system matched with a new engine improves the ZX-7G fuel efficiency and fuel cost.

Reducing fuel consumption

With the reduction of fuel consumption in each mode compared to conventional models, the new model will contribute to increasing your profit.

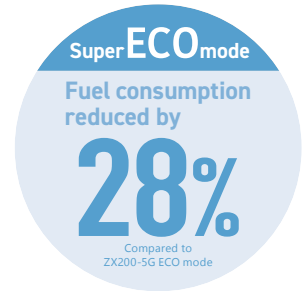
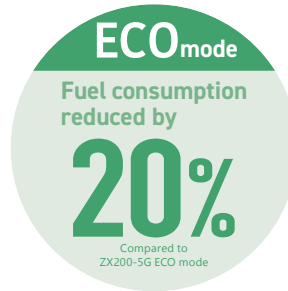
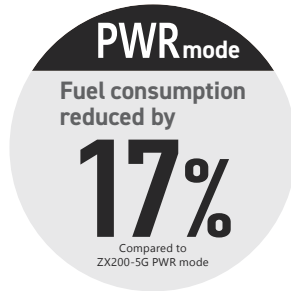

Super ECO mode

The Super ECO mode has been newly added for more fuel-efficient operation. This mode is better suited for light work.

HIOS III hydraulic system

The hydraulic system developed was based on the concept of a hydraulic system that fits in-line with a sense of human operation.

✓ Efficient hydraulic control achieves smoother and more speedy movement of front attachments.

Fine-tuned hydraulic pump control

A solenoid valve mounted on the hydraulic system further controls the pump flow rate to reduce unnecessary load on the engine.

✓ Contributing to low fuel consumption operation

High efficiency engine

A common rail type fuel injection system is used to electronically control fuel quantity and injection timing for more efficiency in fuel combustion.

✓ Contributing to high engine power and low fuel consumption.



Operation support system for high efficiency

ECO gauge

A gauge displays the current fuel consumption during an operation with a higher mark on the gauge indicating a lower fuel usage. The eco-gauge helps to support the operator in achieving lower fuel consumption throughout the work required.

ECO guidance

Prompts the operator to better fuel economy. Messages are also shown while the ECO gauge is displayed.

✓ Prompts operator for better economy

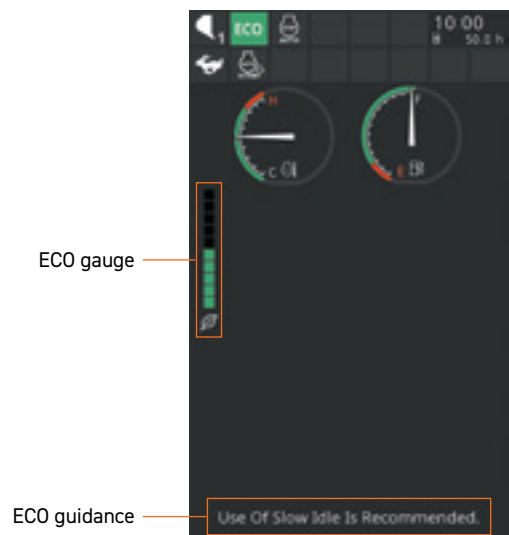



BETTER OPERABILITY

In the cab of the ZAXIS-7G, enhanced comfort and safety features are at your fingertips, offering the power to perform greater productivity with ease as well as reduced fatigue.



Operation is easy with ergonomically designed controls and switches.



Low-reflective color 8" monitor, 42% larger display compared to ZX-5G series. Easier to view and navigate. Bluetooth® and optional USB power supply available.



New designed pilot shut-off lever
The newly designed pilot shut-off lever allows easier locking and unlocking with wrist operation.



AERIAL ANGLE
270-degree bird's eye-view camera system gives exceptional visibility from the cab.

HIGH DURABILITY AND RELIABILITY

Completing a project on time and on budget depends on the ability of your construction equipment to perform all day, every day. That's why the owners have profited from generations of reliable and durable machinery. Hitachi Construction Machinery develops its machines with constant awareness of the need to further improve long-term reliability. High long-term reliability is good in not only performance all day, every day but also for resale value.

An engine with improved reliability

The engine is a highly reliable model that has already been adopted previously. In adopting it for the ZX-7G, we have put in our efforts to further increase durability and to boost your uptime. EGR (Exhaust Gas Recirculation) is removed from the engine, increasing its durability for using low-quality fuel.



Structurally improved upper roller, lower roller, and the front idler

- ✓ Maintains lubrication performance in the roller and improves roller durability





High reliable fuel circuit

Larger fuel pump and changing filter location improve the reliability of the entire fuel circuit and further help to prevent engine problems. Contributing to boost your uptime.



Reinforced platform plate

- ✓ Increased plate strength and deformation-resistant structure



Equipped with an expansion tank

- ✓ Improving the reliability of the engine cooling performance



SMOOTH MAINTENANCE

Regular maintenance is essential for the machine to achieve high performance.

ZAXIS excavators are designed for ease of regular maintenance. Simple and easy maintenance keeps the machine in good condition and keeps its high performance.

Easy to clean radiator/Oil cooler/Inter cooler core

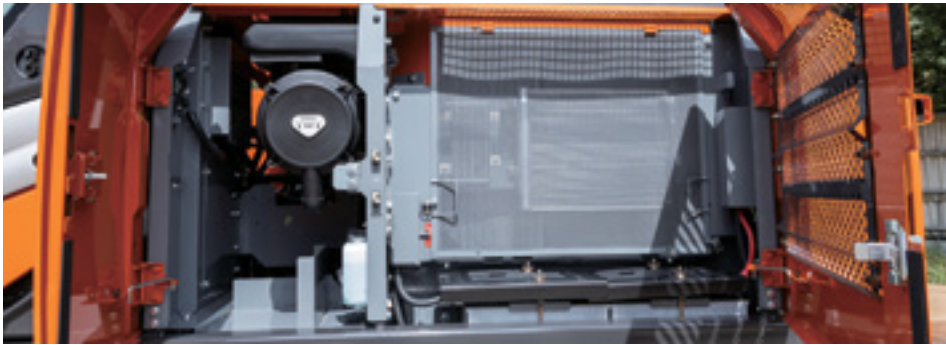

Dust-proof indoor net

- ✓ Provided at the front of radiator
- ✓ Easy to be removed and cleaned



Cleaning port for radiator/Oil cooler/Inter cooler core

- ✓ The cover can be opened without the need for any tools
- ✓ Easy to clean radiator/Oil cooler/Inter cooler core with simple air blowing



Easy-access air conditioner condenser

- ✓ The condenser can be opened
- ✓ Easy to clean radiator/Oil cooler/Inter cooler core with simple air blowing

Remote lubrication of arm-end pin

- ✓ Reducing the risk of mud stuck in the lubrication port
- ✓ Performs smooth lubrication



Easy access to filters

Filter locations are concentrated in the pump room

- 1 Engine oil filter
- 2 Fuel pre-filter with water separator
- 3 Fuel main filter
- 4 Pilot filter

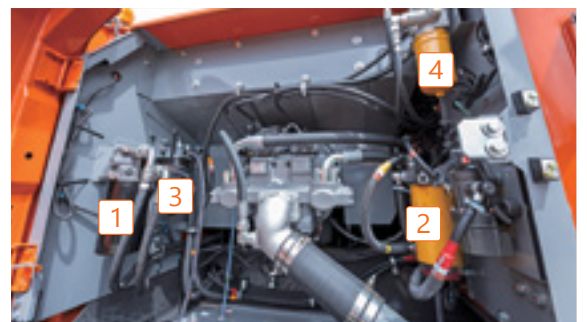



Handrail

Handrails have been installed on the platform to allow safer access to the engine and maintenance work around the engine.
(Full handrails - optional)



MACHINE MANAGEMENT

Hitachi Construction Machinery offers a wide range of after-sales services to help you feel in total control of your fleet and workload. These initiatives give you access to vital data and tools to manage your machine.



ConSite
Consolidated Solution for Construction Sites



A wide range of data on Global e-Service enhances efficiency.

Data report

Regular reports inform you of the machine's operation status. Emergency reports inform you of alarm information.

The stable operation of the machine is further supported with two types of reports visualizing the machine's daily operation status.

Monthly report

Regular reports on the operating status of each machine.

Alarm report

If an emergency alarm is generated from a sensor mounted on the machine, its alarm content is reported by e-mail in a timely manner. You can receive it on your computer, mobile phone, or smartphone (communication format is via e-mail).

movie for further info.





ConSite Pocket

ConSite Pocket sends you real-time alerts for issues arising with your machine. You'll receive recommendations on what to do and step-by-step help guides. The app also enables you to see the location of your fleet.

- Use your smartphone to check monthly reports, alarm reports, as well as machine operating positions.
- If an alarm report is generated, the system will notify you immediately using a push notification.

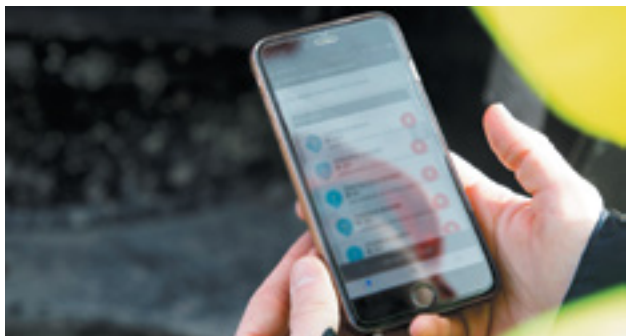

Monthly report



Machine finder

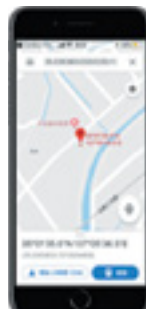

Location information

movie for further info.

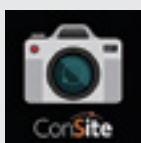

ConSite Shot

This is a smartphone application that allows you to easily perform daily inspections of your machines and rental warehousing / delivery management.

- You can easily create high-quality inspection reports and share information within your company or with agents etc.
- Customers who have rental machines can also use it during rental warehousing / delivery inspections.



Load condition

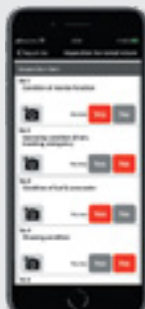

Acceptance or delivery inspection of rental machines



Inspection report with condition photo

movie for further info.



ConSite OIL

This system detects if the oil quality has deteriorated, due to contamination or low viscosity. If this happens, you and your authorized dealer will receive an alert.

movie for further info.



SPECIFICATIONS

ENGINE	
Model	Isuzu AF-4HK1XWSA
Type	4-cycle water-cooled, direct injection
Aspiration	Turbocharged, intercooled
No. of cylinders	4
Rated power	
ISO 14396 : 2002 gross	120 kW (161 HP) at 2 000 min ⁻¹ (rpm)
ISO 9249 : 2007 net	113 kW (152 HP) at 2 000 min ⁻¹ (rpm)
Maximum torque	657 Nm (67 kgfm) at 1 500 min ⁻¹ (rpm)
Piston displacement	5.193 L
Bore and stroke	115 mm x 125 mm
Batteries	2 x 12 V

HYDRAULIC SYSTEM			
Hydraulic Pumps			
Main pumps	2 variable displacement axial piston pumps		
Maximum oil flow	2 x 212 L/min		
Pilot pump	1 gear pump		
Maximum oil flow	30.2 L/min		
Hydraulic Motors			
Travel	2 variable displacement axial piston motors		
Swing	1 axial piston motor		
Relief Valve Settings			
Implement circuit	34.3 MPa (350 kgf/cm ²)		
Swing circuit	34.3 MPa (350 kgf/cm ²)		
Travel circuit	34.3 MPa (350 kgf/cm ²)		
Pilot circuit	3.9 MPa (40 kgf/cm ²)		
Power boost	38.0 MPa (388 kgf/cm ²)		
Hydraulic Cylinders			
	Quantity	Bore	Rod diameter
Boom	2	120 mm	85 mm
Arm	1	135 mm	95 mm
Bucket	1	115 mm	80 mm

UPPERSTRUCTURE	
Revolving Frame	
D-section frame for resistance to deformation.	
Swing Device	
Axial piston motor with planetary reduction gear is bathed in oil. Swing circle is single-row. Swing parking brake is spring-set/hydraulic-released disc type.	
Swing speed	13.5 min ⁻¹ (rpm)
Swing torque	68 kNm (6 900 kgfm)

UNDERCARRIAGE	
Tracks	
Heat-treated connecting pins with dirt seals. Hydraulic (grease) track adjusters with shock-absorbing recoil springs.	
Numbers of Rollers and Shoes on Each Side	
Upper rollers	2
Lower rollers	8 : ZX210LC-7G
Track shoes	49 : ZX210LC-7G
Track guards	2 : ZX210LC-7G
Travel Device	
Each track driven by 2-speed axial piston motor. Parking brake is spring-set/hydraulic-released disc type. Automatic transmission system : High-Low.	
Travel speeds	High : 0 to 5.5 km/h
	Low : 0 to 3.5 km/h
Maximum traction force	203 kN (20 700 kgf)
Gradeability	70% (35 degree) continuous

SERVICE REFILL CAPACITIES	
Fuel tank	400.0 L
Engine coolant	31.0 L
Engine oil	23.0 L
Swing device	6.2 L
Travel device (each side)	6.8 L
Hydraulic system	240.0 L
Hydraulic oil tank	135.0 L

WEIGHTS AND GROUND PRESSURE

Operating Weight and Ground Pressure

			ZX210LC-7G ^{*1}		
Boom type			Monoblock		
Shoe type	Shoe width (mm)	Arm length (m)	kg	kPa	kgf/cm ²
Triple grouser	600	2.42	20 800	43	0.44
		2.91	20 800	43	0.44
	700	2.42	21 200	38	0.38
		2.91	21 200	38	0.38
	800	2.42	21 500	33	0.34
		2.91	21 500	33	0.34

*1 : Including 0.80 m³ (ISO 7451 : 2007 heaped) bucket weight (660 kg) and counterweight (4 250 kg).

BASIC MACHINE WEIGHT AND COMPONENTS WEIGHT

Basic Machine Weight and Overall Width

Excluding front end attachment, fuel, hydraulic oil and coolant etc. Including counterweight.

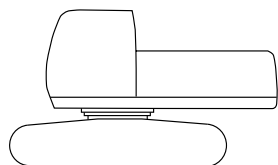

			ZX210LC-7G	
Shoe width (mm)	Weight (kg)	Overall width (mm)		
600	16 400	2 990		
700	16 800	3 090		
800	17 100	3 190		

Components Weight

Unit: kg

		ZX210LC-7G
Counterweight		4 250
Boom (with boom and arm cylinder)		2 130
2.42 m arm (with bucket cylinder)		960
2.91 m arm (with bucket cylinder)		1 010
0.80 m ³ bucket		660

BUCKET AND ARM DIGGING FORCE

Arm length	2.42 m		2.91 m	
	kN	kgf	kN	kgf
Bucket digging force ISO 6015 : 2006	158	16 200	158	16 200
Arm crowd force ISO 6015 : 2006	140	14 200	114	11 600

At power boost

SPECIFICATIONS

BACKHOE ATTACHMENTS

ZX210LC-7G

Bucket	Capacity (m ³)	Width (mm)		No. of teeth	Weight (kg)	Recommendation	
	ISO7451: 2007 heaped	Without side cutters	With side cutters			Arm 2.42 m	Arm 2.91 m
Hoe bucket (Level-pin type)	0.80	1 030	1 140	5	660	⊙	⊙
	0.91	1 150	1 260	5	700	⊙	⊙
	1.10	1 330	1 440	6	770	○	○
Reinforced bucket (Level-pin type)	0.80	1 030	1 140	5	750	⊙	⊙
	0.91	1 150	1 260	5	800	⊙	⊙
	0.91	1 150	1 260	5	800	⊙	⊙
H-bucket (Level-pin type)	0.80	1 030	1 140	5	770	⊙	⊙
	0.80	1 030	1 140	5	770	⊙	⊙
Rock bucket (Level-pin type)	1.10	1 330	1 440	6	940	○	○

⊙ Suitable for materials with density of 2 000 kg/m³ or less

○ Suitable for materials with density of 1 600 kg/m³ or less

□ Suitable for materials with density of 1 100 kg/m³ or less

– Not applicable

SPECIFICATIONS

WORKING RANGES

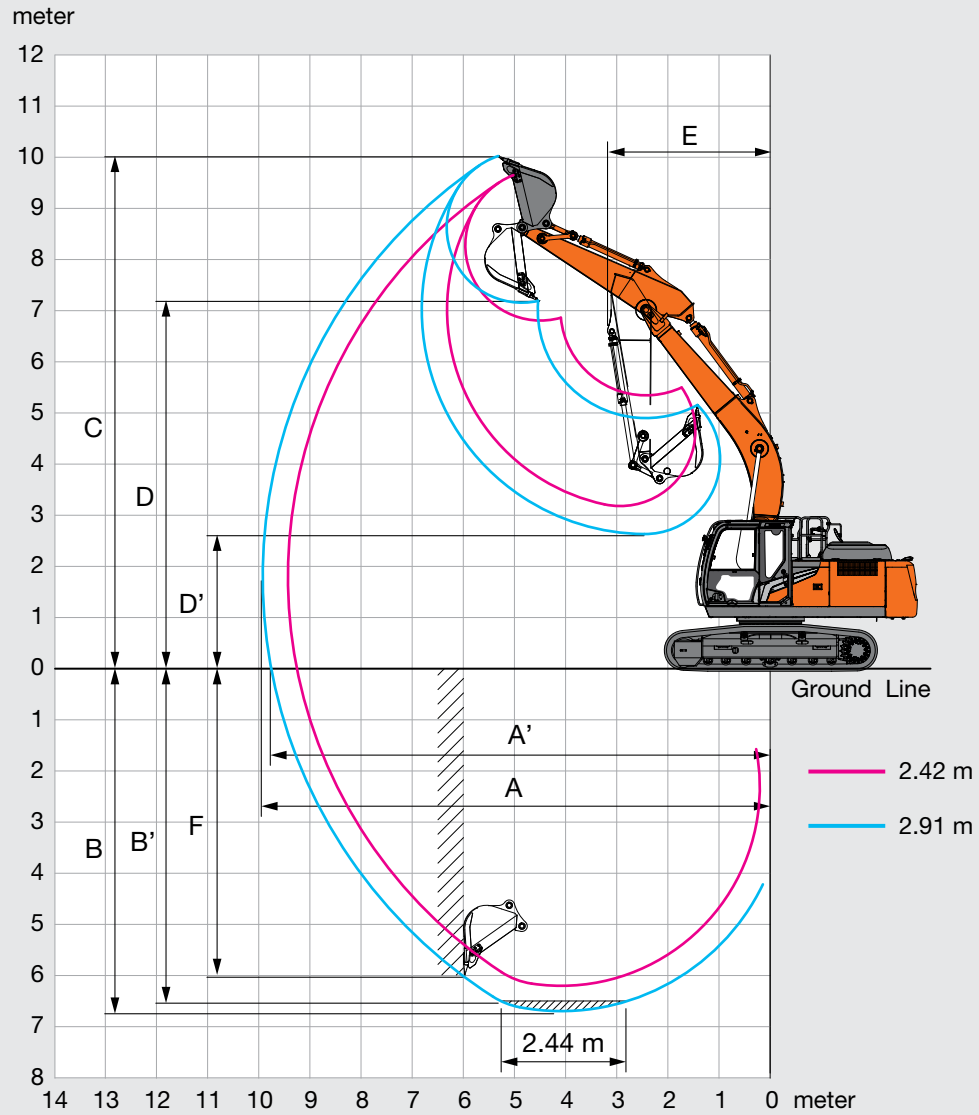

Unit: mm

Arm length	2.42 m	2.91 m
A Max. digging reach	9 430	9 920
A' Max. digging reach (on ground)	9 250	9 750
B Max. digging depth	6 180	6 670
B' Max. digging depth for 2.44 m level	5 950	6 480
C Max. cutting height	9 670	10 040
D Max. dumping height	6 830	7 180
D' Min. dumping height	3 200	2 650
E Min. swing radius	3 280	3 180
F Max. vertical wall digging depth	5 300	5 990

Excluding track shoe lug

DIMENSIONS

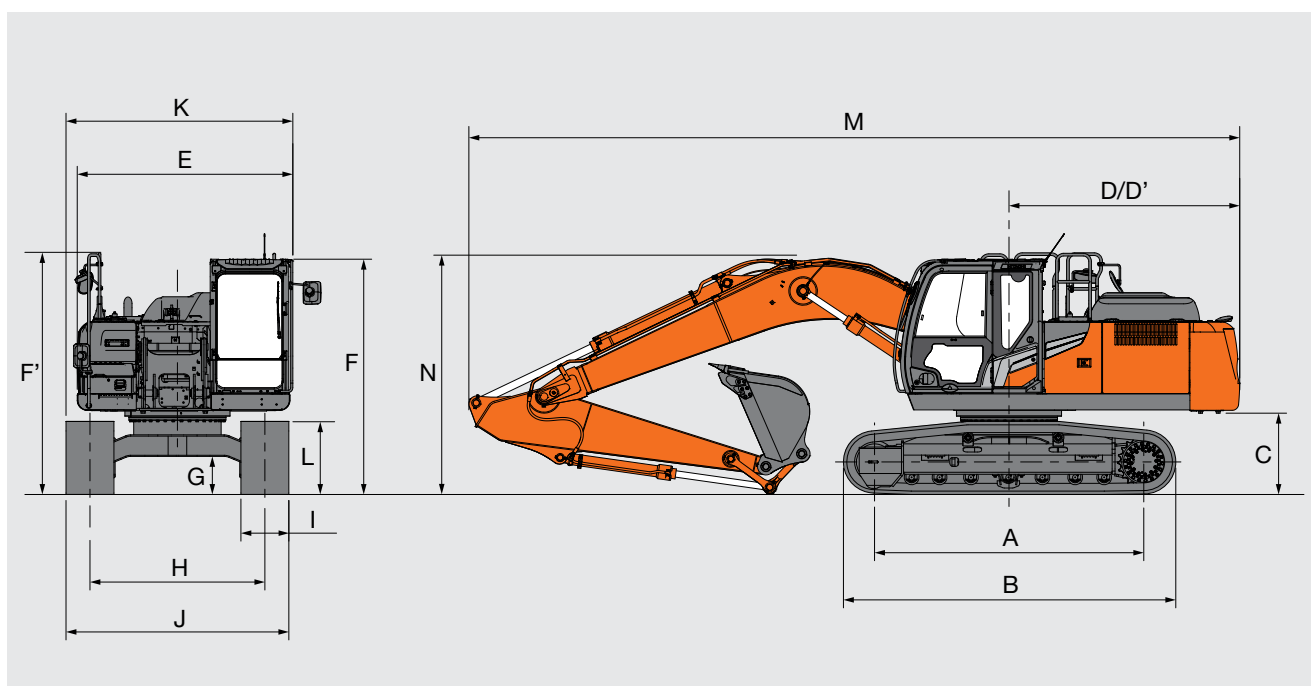

Unit: mm

	ZX210LC-7G
A Distance between tumblers	3 660
B Undercarriage length	4 450
*C Counterweight clearance	990
D Rear-end swing radius	2 890
D' Rear-end length	2 890
E Overall width of upperstructure	2 700
F Overall height of cab	2 950
F' Overall height of upperstructure	3 030
*G Min. ground clearance	450
H Track gauge	2 390
I Track shoe width	600
J Undercarriage width	2 990
K Overall width	2 990
*L Track height with triple grouser shoes	900
M Overall length	
With 2.42 m arm	9 750
With 2.91 m arm	9 660
*N Overall height of boom	
With 2.42 m arm	3 200
With 2.91 m arm	3 000

* Excluding track shoe lug G: Triple grouser shoe

MACHINE CAPACITIES

- Notes:
1. Ratings are based on ISO 10567 : 2007.
 2. Lifting capacity does not exceed 75% of tipping load with the machine on firm, level ground or 87% full hydraulic capacity
 3. The load point is the center-line of the bucket pivot mounting pin on the arm.
 4. *Indicates load limited by hydraulic capacity.
 5. 0 m = Ground.

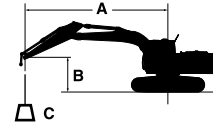

A: Load radius
 B: Load point height
 C: Machine capacity

For machine capacities, subtract installed attachment and quick hitch weight from machine capacities.

To determine lifting capacities, apply "Rating over-side or 360 degrees" machine capacities from the table and deduct weight of installed attachment and quick hitch. Optional feature may affect machine performance.

ZX210LC-7G

Rating over-front Rating over-side or 360 degrees Unit : kg

Conditions	Load point height m	Load radius										At max. reach		
		1.5 m		3.0 m		4.5 m		6.0 m		7.5 m				meter
Boom 5.68 m Arm 2.42 m Counterweight 4 250 kg Shoe 600 mm	6.0							*5 740	5 270			*5 770	4 350	6.74
	4.5					*7 320	*7 320	*6 220	5 120			5 500	3 620	7.48
	3.0					*9 190	7 380	*7 020	4 890	5 390	3 530	5 000	3 280	7.87
	1.5					*10 700	6 930	7 350	4 670	5 280	3 430	4 850	3 160	7.95
	0 (Ground)					*11 220	6 740	7 200	4 530	5 210	3 370	4 990	3 230	7.74
	-1.5			*9 900	*9 900	*10 880	6 720	7 150	4 500			5 510	3 550	7.21
	-3.0			*13 190	*13 190	*9 700	6 820	*7 140	4 580			*6 650	4 320	6.28
	-4.5					*6 860	*6 860					*6 420	*6 420	4.71
	-6.0													
Boom 5.68 m Arm 2.91 m Counterweight 4 250 kg Shoe 600 mm	6.0							*5 210	*5 210			*4 030	3 840	7.32
	4.5					*6 600	*6 600	*5 760	5 180	*5 380	3 650	*3 980	3 270	8.01
	3.0					*8 510	7 530	*6 630	4 940	5 410	3 550	*4 090	2 990	8.37
	1.5					*10 240	7 030	7 390	4 700	5 290	3 430	*4 360	2 890	8.45
	0 (Ground)			*4 840	*4 840	*11 090	6 750	7 200	4 530	5 190	3 340	4 530	2 940	8.25
	-1.5	*5 470	*5 470	*9 090	*9 090	*11 060	6 680	7 120	4 460	5 160	3 320	4 930	3 180	7.76
	-3.0	*9 960	*9 960	*14 350	13 080	*10 200	6 740	7 150	4 490			5 860	3 760	6.90
	-4.5			*11 220	*11 220	*8 100	6 950					*6 230	5 240	5.52
	-6.0													

EQUIPMENT

● : Standard equipment ○ : Optional equipment – : Not applicable

ENGINE	
Air cleaner double filters	●
Alternator 50 A	●
Auto idle system	●
Auto shut-down control	●
Cartridge-type engine oil filter	●
Cartridge-type fuel main filter	●
Cartridge-type fuel pre-filter with water separator	●
Cold fuel resistance valve	●
ConSite OIL (sensor) ¹	●
Dry-type air filter with evacuator valve (with air filter restriction indicator)	●
Dust-proof indoor net	●
ECO/PWR mode control	●
Electrical fuel feed pump	●
Engine oil drain coupler	●
Expansion tank	●
Fan guard	●
Fuel cooler	●
Isolation-mounted engine	●
Maintenance free pre-cleaner	●
Radiator, oil cooler and intercooler	●

HYDRAULIC SYSTEM	
Auto power lift	●
ConSite OIL (sensor) ¹	●
Control valve with main relief valve	●
Full flow filter	●
One extra port for control valve	●
Pilot filter	●
Power boost	●
Suction filter	●
Work mode selector	●

CAB	
All-weather sound suppressed steel cab	●
Auto control air conditioner	●
Bluetooth® integrated radio	●
Cab : CRES VII (center pillar reinforced structure) cab	●
Cab : ROPS (ISO12117-2 : 2008) compliant	●
Console height adjustment	●
Drink holder with hot and cool function	●
Electric double horn	●
Engine shut-off switch	●
Equipped with reinforced, tinted (green color) glass windows	●
Evacuation hammer	●
Floor mat	●
Footrest	●
Front guard : OPG front guard level II (ISO10262 : 1998) compliant	○
Front window washer (1 point)	●
Glove compartment	●
Hands-free calling device	●
Hot and cool box	●
Intermittent windshield wipers	●
Key cylinder light	●
LED room light	●
Magazine rack	●
Pilot shut-off lever	●
Power outlet 12 V	●
Power outlet 24 V	●
Rear tray	●
Retractable seat belt	●
Rubber radio antenna	●
Seat : air suspension seat with heater	●
Seat adjustment part : backrest, armrest, height and angle, slide forward / back	●
Seat belt reminder	●
Short wrist control levers	●
Smartphone holder	●
Top guard : OPG top guard Level II (ISO10262 : 1998) compliant	●
USB power supply	●
Windows on front, upper, lower and left side can be opened	●
2 speakers	●
4 fluid-filled elastic mounts	●
8 inch monitor	●

● : Standard equipment ○ : Optional equipment – : Not applicable

MONITOR SYSTEM	
Alarms: overheat, engine warning, engine oil pressure, alternator, minimum fuel level, hydraulic filter restriction, air filter restriction, work mode, overload, etc	●
Alarm buzzers: overheat, engine oil pressure, overload, trouble, etc	●
Display of meters: water temperature, hour, fuel rate, clock, etc	●
Other displays: work mode, auto-idle, glow, rear view monitor, operating conditions, etc	●
35 languages selection	●

LIGHTS	
Additional boom LED light with cover	○
Additional cab roof front LED lights	●
Additional cab roof rear LED lights	●
LED lights for camera (side and rear view camera)	●
2 working LED lights	●

UPPER STRUCTURE	
AERIAL ANGLE (270-degree view camera system)	●
Batteries	●
Counterweight 4 250 kg	●
Fuel level float	●
Hydraulic oil level gauge	●
Lockable fuel refilling cap	●
Lockable machine covers	●
Lockable tool box	●
Platform handrail	●
Platform handrail (additional)	○
Rear view camera	●
Skid-resistant plates	●
Swing parking brake	●
Undercover	●
Undercover 6.0 mm reinforced	●
Utility space	●
2 way disconnect switch	●

UNDERCARRIAGE	
Bolt-on sprocket	●
Greasing type track adjuster	●
Reinforced track links with pin seals	●
Shoe: 600 mm triple grouser	●
Shoe: 700 mm triple grouser	○
Shoe: 800 mm triple grouser	○
Towing hook	●
Track side step	●
Track undercover	●
Travel direction mark on track frame	●
Travel motor covers	●
Travel parking brake	●
Upper and lower rollers	●
2 track guards (each side)	●
4 tie down hooks	●

FRONT ATTACHMENTS	
Arm tip remote lubrication	●
Arm 2.42 m	○
Arm 2.91 m	●
Boom 5.68 m H	●
Bucket 0.8 m ³ (ISO7451 : 2007 heaped)	○
Casted bucket link A	●
Centralized lubrication system	●
Dirt seal on all bucket pins	●
Flanged pin	●
HN bushing	●
Reinforced link B	●
Reinforced resin thrust plate	●
WC (tungsten-carbide) thermal spraying	●

ATTACHMENTS	
Attachment basic piping	●
Breaker and crusher piping	●
Pilot accumulator	●

MISCELLANEOUS	
ConSite	●
Global e-Service	●
Onboard information controller	●
Standard tool kit	●

Standard and optional equipment may vary by country, so please consult authorized dealer for details.

*1 Engine oil and hydraulic oil monitoring sensor.

*2 700 mm and 800 mm shoes are for soft soil, so please be careful when using H specification machines.

*3 Hitachi Construction Machinery cannot be held liable for theft, any system will just minimize the risk of theft.

Prior to operating this machine, including satellite communication system, in a country other than a country of its intended use, it may be necessary to make modifications to it so that it complies with the local regulatory standards (including safety standards) and legal requirements of that particular country. Please do not export or operate this machine outside the country of its intended use until such compliance has been confirmed. Please contact your Hitachi dealer in case of questions about compliance.

CablePrice Pty Ltd

www.cableprice.co.nz

Hitachi Construction Machinery Australia

www.hitachicm.com.au

These specifications are subject to change without notice.

Illustrations and photos show the standard models, and may or may not include optional equipment, accessories, and all standard equipment with some differences in color and features. Before use, read and understand the Operator's Manual for proper operation.

KS-EN573AU

00.00 (---/--- ---)

Printed in Australia